

Mr L. G. Pocock

3323

# ELECTRICAL COMMUNICATION

*Technical Journal of the  
International Telephone and Telegraph Corporation  
and Associate Companies*

---

200-KILOWATT HIGH-FREQUENCY BROADCAST TRANSMITTERS

ARMY AIR FORCES' PORTABLE INSTRUMENT LANDING SYSTEM

APPLICATIONS OF HIGH-FREQUENCY SOLID-DIELECTRIC FLEXIBLE  
LINES TO RADIO EQUIPMENT

ROTARY AUTOMATIC EQUIPMENT TO BE INSTALLED IN LEXINGTON,  
KENTUCKY, AND ROCHESTER, NEW YORK

TROPICAL MOISTURE AND FUNGI: PROBLEMS AND SOLUTIONS

TWENTY YEARS OF TELEPHONY IN SPAIN

STANDARD TELEPHONES AND CABLES PTY. LTD., AUSTRALIA—  
50TH ANNIVERSARY

SIMULTANEOUS USE OF CENTIMETER WAVES AND FREQUENCY MODULATION

THYRATRONS AND THEIR APPLICATIONS TO RADIO ENGINEERING

THE MEASURED CHARACTERISTICS OF SOME ELECTROSTATIC  
ELECTRON LENSES—DISCUSSION

RECENT TELECOMMUNICATION DEVELOPMENTS

---

1945

VOL. 22

No. 4

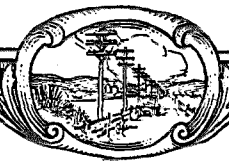

# ELECTRICAL COMMUNICATION

Technical Journal of the  
INTERNATIONAL TELEPHONE AND TELEGRAPH CORPORATION  
and Associate Companies

H. T. KOHLHAAS, Editor

F. J. MANN, Managing Editor

H. P. WESTMAN, Associate Editor

### REGIONAL EDITORS

E. G. PORTS, Federal Telephone & Radio Corporation, Newark, New Jersey  
B. C. HOLDING, Standard Telephones & Cables, Ltd., London, England  
S. VAN MIERLO, Laboratoire Central de Télécommunications, Paris, France

### EDITORIAL BOARD

H. Busignies      H. H. Buttner      G. Deakin      E. M. Deloraine      W. T. Gibson  
Sir Frank Gill      W. Hutton      E. Labin      E. S. McLarn      A. W. Montgomery  
Haraden Pratt      G. Rabuteau      T. R. Scott      C. E. Strong      E. N. Wendell      W. K. Weston

Published Quarterly by the

## INTERNATIONAL TELEPHONE AND TELEGRAPH CORPORATION

67 BROAD STREET, NEW YORK 4, N.Y., U.S.A.

Sosthenes Behn, President

Charles D. Hilles, Jr., Vice President and Secretary

Subscription, \$1.50 per year; single copies, 50 cents

Copyrighted 1945 by International Telephone and Telegraph Corporation

Volume 22

1945

Number 4

## CONTENTS

	PAGE
200-KILOWATT HIGH-FREQUENCY BROADCAST TRANSMITTERS ...	253
<i>By H. Romander</i>	
ARMY AIR FORCES' PORTABLE INSTRUMENT LANDING SYSTEM ...	262
<i>By Sidney Pickles</i>	
APPLICATIONS OF HIGH-FREQUENCY SOLID-DIELECTRIC FLEXIBLE LINES TO RADIO EQUIPMENT .....	295
<i>By H. Busignies</i>	
ROTARY AUTOMATIC EQUIPMENT TO BE INSTALLED IN LEXINGTON, KENTUCKY, AND ROCHESTER, NEW YORK .....	302
TROPICAL MOISTURE AND FUNGI: PROBLEMS AND SOLUTIONS ....	303
<i>By E. S. McLarn, Harry Oster, Henry Kolin, and A. Neumann</i>	
TWENTY YEARS OF TELEPHONY IN SPAIN .....	314
<i>By O. C. Bagwell and J. J. Parsons</i>	
STANDARD TELEPHONES AND CABLES PTY. LTD., AUSTRALIA—50TH ANNIVERSARY .....	322
<i>By J. Clarke</i>	
SIMULTANEOUS USE OF CENTIMETER WAVES AND FREQUENCY MODULATION .....	326
<i>By A. G. Clavier and V. Altovsky</i>	
THYRATRONS AND THEIR APPLICATIONS TO RADIO ENGINEERING ..	339
<i>By A. J. Maddock</i>	
THE MEASURED CHARACTERISTICS OF SOME ELECTROSTATIC ELEC- TRON LENSES—DISCUSSION .....	379
RECENT TELECOMMUNICATION DEVELOPMENTS .....	380

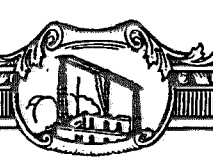

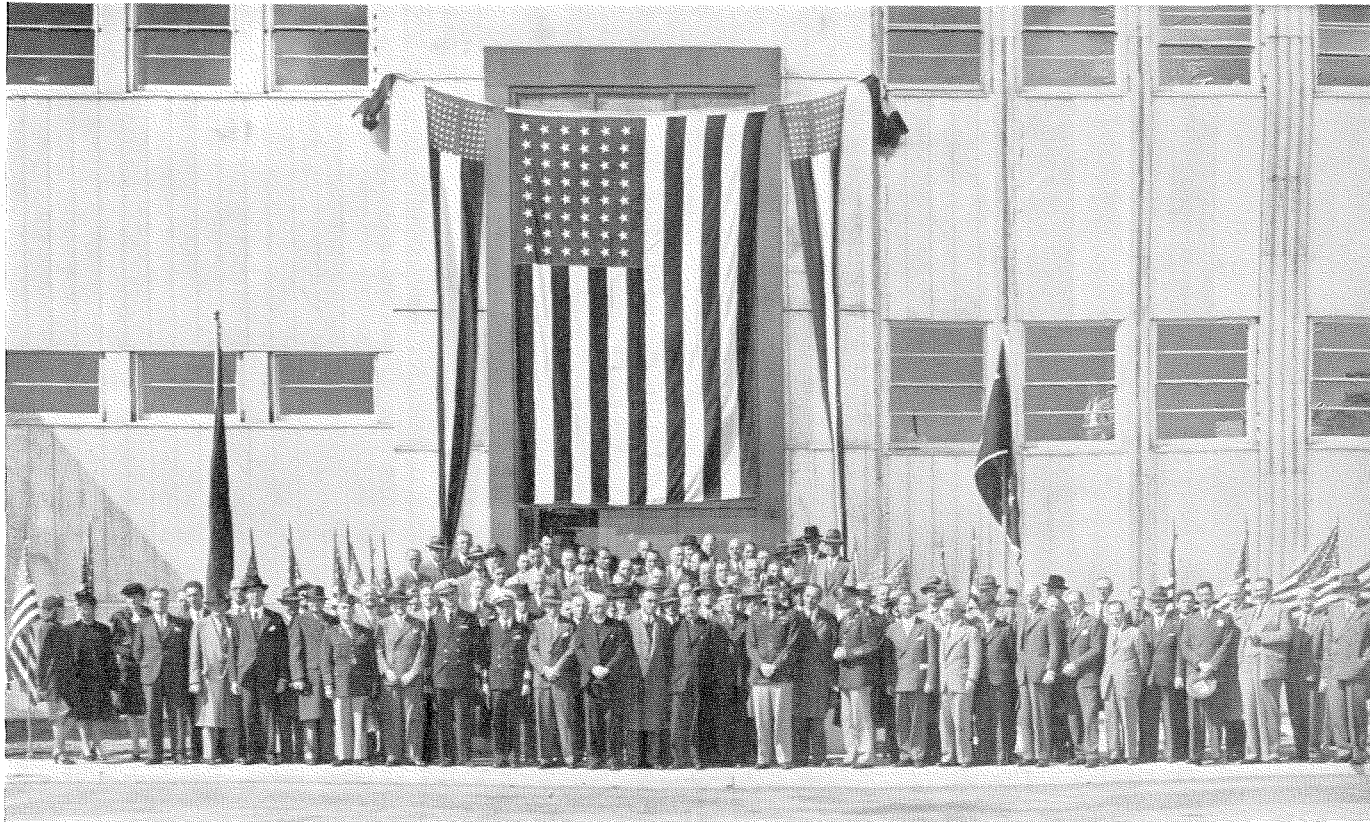

PHOTOGRAPH TAKEN ON THE OCCASION OF THE DEDICATION ON OCTOBER 3RD OF THE NEW NUTLEY (NEW JERSEY) LABORATORIES OF FEDERAL TELECOMMUNICATION LABORATORIES, INC. AMONG THE GUESTS WERE REPRESENTATIVES OF THE ARMED FORCES AND DELEGATES FROM I. T. & T. ASSOCIATE COMPANIES WHO ATTENDED THE I. T. & T. VICTORY DEVELOPMENT CONFERENCE HELD IN NEW YORK, SEPTEMBER 24-OCTOBER 5, 1945. THIS CONFERENCE RESUMED THE PREWAR PRACTICE OF ASSEMBLING REPRESENTATIVES FROM MANY COUNTRIES ANNUALLY FOR THE EXCHANGE OF SCIENTIFIC KNOWLEDGE AND THE COORDINATION OF DEVELOPMENT PROJECTS.

# 200-Kilowatt High-Frequency Broadcast Transmitters

By H. ROMANDER

*Federal Telephone and Radio Corporation, Newark, New Jersey*

**W**ITH the close of hostilities in Europe, the United States supplemented its intensification of war activities in the Pacific with augmented facilities for radio broadcasting. Two of the most powerful high-frequency broadcast transmitters in the world were placed in service in locations near the West Coast where coverage of the western Pacific area is more effectively made than from any other region of the continental United States. Built to specifications of the Office of War Information, each transmitter supplies a carrier power of 200 kilowatts to rhombic antennas directed to various sectors of the orient.

The transmitters were installed in newly completed stations at Delano (near Bakersfield) and Dixon (near Sacramento), California. The Columbia Broadcasting System supervised the construction of the building and the installation of primary power-supply equipment at Delano, and the National Broadcasting Company similarly participated in the construction of the Dixon station. The Federal Telephone and Radio Corporation supplied and installed, in addition to the 200-kilowatt power amplifiers, the modulator and all associated rectifier and power-supply equipment, including the water-circulation systems.

## 1. Antennas

The antenna facilities and station layout of both installations are substantially the same. The beam antennas are arranged in groups of three for each sector of the orient to be covered, the antennas of each group being graded in size and height so that a wide range of frequencies may be employed with uniform gain. Transmission lines from each antenna, connected to special outdoor switch gear near the station, permit rapid selection of antennas.

## 2. Station Building

The station building is a single-story structure of poured concrete, with no basement. Acoustic tile for the ceiling and walls and cement flooring are employed in the transmitter room. In general, the station is divided into two duplicate sections, each being complete in itself with separate power and rectifier equipment, water-cooling system, and ventilation blowers. While present plans include a pair of 50-kilowatt transmitters on one side and a single 200-kilowatt transmitter on the other side, the layout is such that a second 200-kilowatt transmitter can be installed in place of the two 50-kilowatt units now in operation.

The general layout of the station equipment is shown in Fig. 1. The front panels for the modulator, rectifier, and radio equipment occupy both sides of the length of the transmitter room and are about 62 feet long. Adjoining the front end of this room is the control room where are located the input audio-frequency equipment monitoring facilities, and the central control panels for the operator. Separate vaults are provided for the larger power-frequency and audio-frequency iron-cored components. The water-cooling and circulating equipment is located in a single room at one end of the building.

A general view of the transmitter room is shown in Fig. 2. Reference to the station plan of Fig. 1 will aid in identifying the individual units. It will be noted that the panels on both sides of the room are identical in appearance except for the second 50-kilowatt radio-frequency unit on the far right which is directly opposite the 200-kilowatt power amplifier on the far left.

## 3. Rectifiers

In addition to the radio-frequency equipment located in the screened enclosures behind the front panels, there are two 12,000-volt rectifiers assembled on racks. Adjacent to these racks are

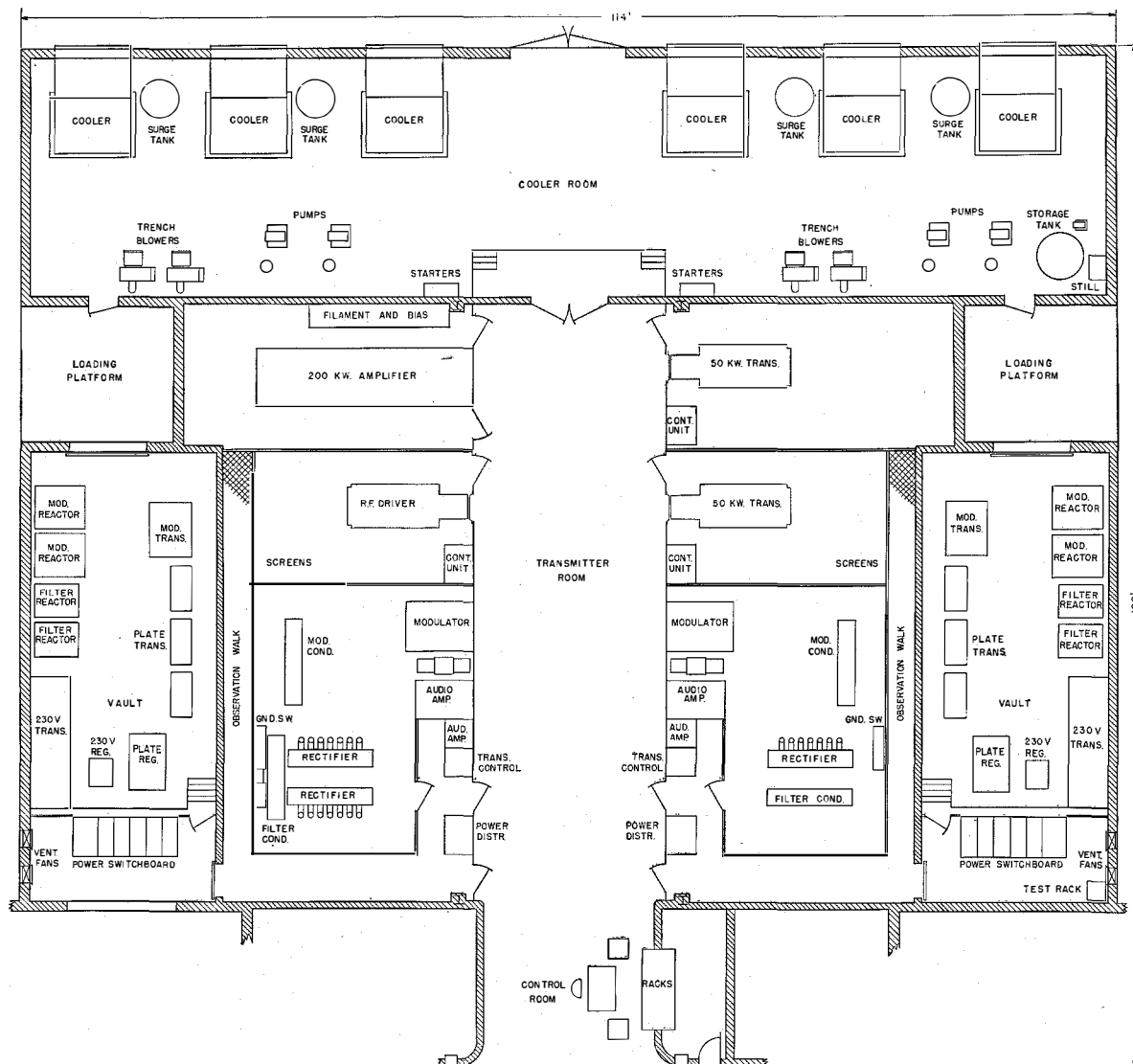

Fig. 1—Floor plan of the high-frequency broadcast stations at Dixon and Delano, California.

the filter capacitor units and the safety grounding switches. Filter chokes and power transformers are located in the transformer vaults. The rectifier on the left side provides plate power for the radio-frequency driver, the 150-kilowatt modulator, and the final 200-kilowatt power amplifier. The rectifier on the right side supplies plate power for the modulator on that side and for the power amplifier in each of the two 50-kilowatt transmitters. Provisions have been made to increase the size of the rectifier on the right side to equal that on the left side, if the

second 50-kilowatt transmitter is replaced by a 200-kilowatt power amplifier.

#### 4. Radio-Frequency Units

Power for excitation of the 200-kilowatt amplifier is obtained from an existing 50-kilowatt transmitter. Originally designed for operation into an antenna, this unit may be used as an exciter with virtually no alteration. The impedance of the radio-frequency input circuit of the amplifier is adjusted to provide the normal

load impedance for the 50-kilowatt exciter so that the output coupling facilities of the latter may be employed without alteration.

The 200-kilowatt power amplifier is contained within a frame which is  $22\frac{1}{2}$  feet long, 6 feet wide, and  $6\frac{1}{2}$  feet high. Fig. 3 shows the front panel from which all circuit adjustments are made with the exception of switching the plate tank circuit capacitors. Only the controls of the two variable capacitors in the input circuit are operated directly by handwheels. All other adjustments are made by reversible, two-speed motors controlled by switches on the front panel. The power amplifier may be adjusted in less than five minutes to any frequency in the range from 6 to 22 megacycles.

### 5. Grounded-Grid Amplifier

Fig. 4 is a simplified schematic diagram of the power-amplifier radio-frequency circuits. Basically, it is a grounded-grid, push-pull amplifier with tuned input and output circuits. This circuit was chosen because its inherent stability at 22 megacycles is greater for the size of tube used than the grounded-filament circuit. Greater

excitation energy is required,<sup>1,2</sup> but there is no sacrifice in overall efficiency. Moreover, the grounded grid acts as an electrostatic shield between the plate and the filament, reducing feed-back effects to such a degree that neutralization is not necessary.

In the grounded-grid amplifier, the excitation voltage is applied between the filament and the grid as shown in Fig. 5. The output load in the plate circuit is also coupled to the excitation source through the electron stream from filament to plate. In this particular design, the power stage develops about 160 kilowatts and the exciter supplies another 40 kilowatts to the plate load. Cascade modulation is used, both the exciter and the amplifier being supplied with modulated plate voltage from the same source.

As the grid is at ground potential and the driving voltage is applied to the filament, radio-frequency chokes are inserted in the filament leads and must carry the relatively large filament

<sup>1</sup> C. E. Strong, "The Inverted Amplifier," *Electrical Communication*, v. 19, n. 3, p. 32, 1941.

<sup>2</sup> E. Labin, "Design of the Output Stage of High Power Television Transmitter," *Electrical Communication*, v. 20, n. 3, p. 193, 1942.

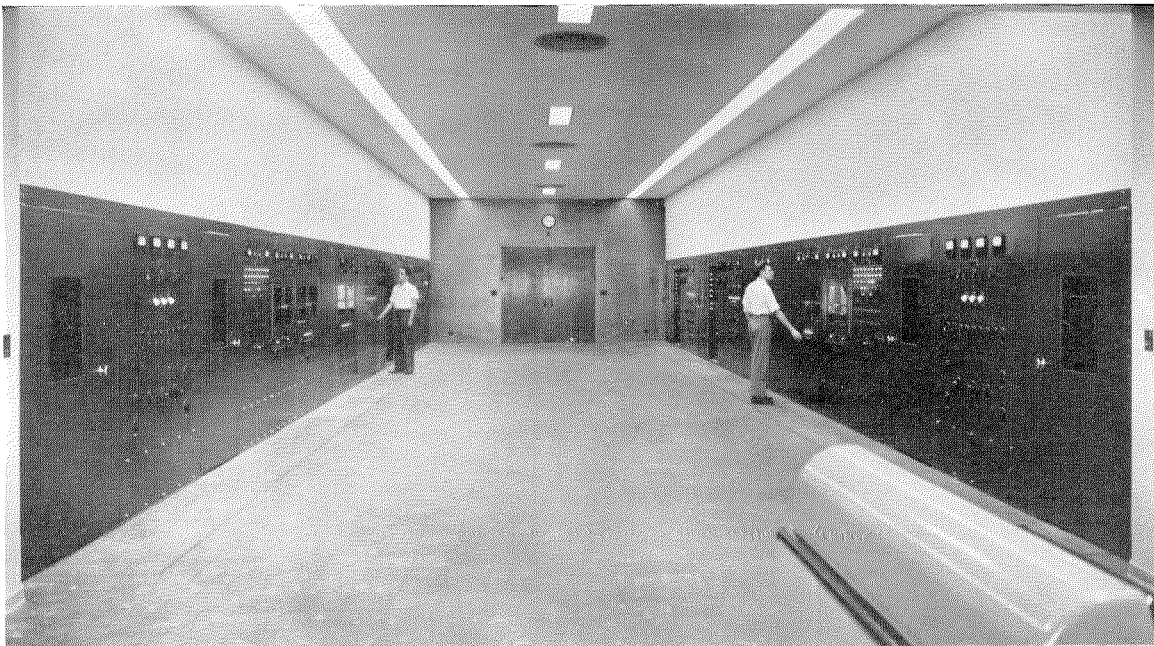

Fig. 2—General view of the transmitter room. The 200-kilowatt amplifier is at the rear left.

heating current. These chokes operate without adjustment over the entire frequency range.

### 6. Output Tubes

Two Federal F-135 water-cooled triodes are used in the power amplifier. This tube is a recent development and utilizes a thoriated tungsten filament. The supporting structure for the grid is designed to minimize the inductance of the grid lead, and care has been taken to make the plate-to-filament capacitance as small as possible.

The principal characteristics of the F-135 tube are as follows:

Plate Dissipation:	100 kilowatts
Direct Interelectrode Capacitances:	
Grid to Plate	125 $\mu\mu\text{f}$
Grid to Filament	125 $\mu\mu\text{f}$
Plate to Filament	4 $\mu\mu\text{f}$
Overall Dimensions:	
Length	30 inches
Diameter of Plate	6 inches
Diameter of Glass Envelope	6½ inches

The filaments of the tubes are fed from a pair of transformers connected in open delta to the 230-volt, three-phase supply. When first applying power, resistors in the primary circuit limit

the initial surge of current to the cold filaments to less than 1.5 times normal current. Motor-operated, air-cooled induction regulators control the primary voltage so that the filament voltage may be adjusted by remote control.

### 7. Circuit Elements

The input circuit employs two parallel copper pipes, 18 inches apart and about 12 feet long, one end connected to the filaments of the power-amplifier tubes and the other end to the transmission lines from the 50-kilowatt exciter. This circuit is tuned by means of two variable capacitors, one of which is fixed in position at the filament end. The other may be adjusted in its physical position along the two pipes by means of a motor controlled from the front panel. The input impedance to the amplifier may thus be adjusted to a purely resistive 400 ohms at any operating frequency.

The plate circuit also employs copper-pipe inductances. Two parallel branches, each approximately 18 feet in length, are used. The inductance of one branch is varied by means of a shorting bar which is shifted along the pipes by a motor-driven stainless steel belt. The inductance of the other branch remains fixed

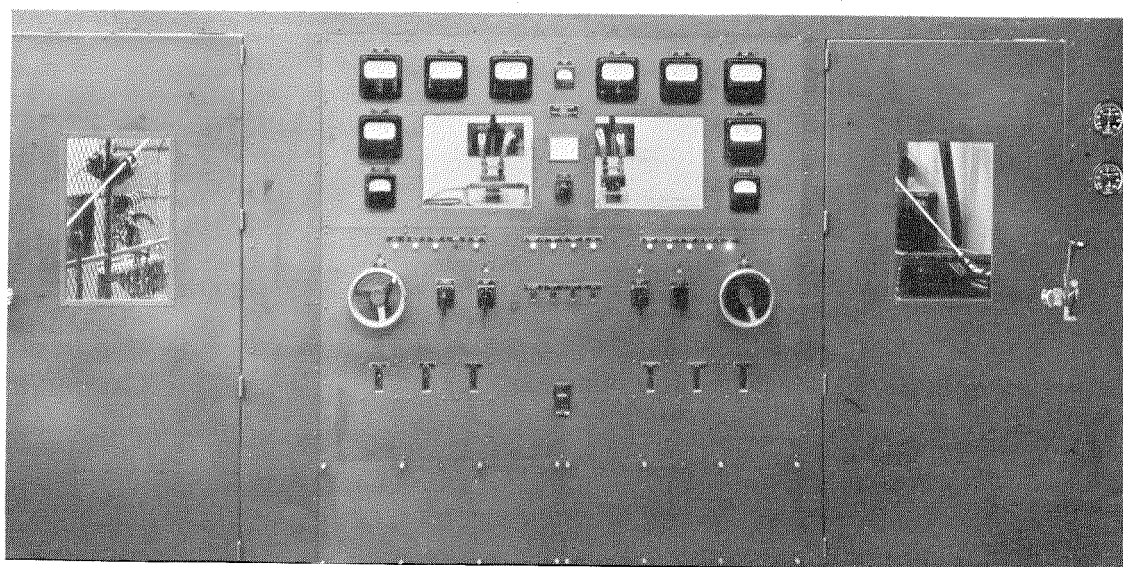

Fig. 3—Front view of 200-kilowatt amplifier. The two handwheels control the input-circuit tuning capacitors. All other controls are motor operated.

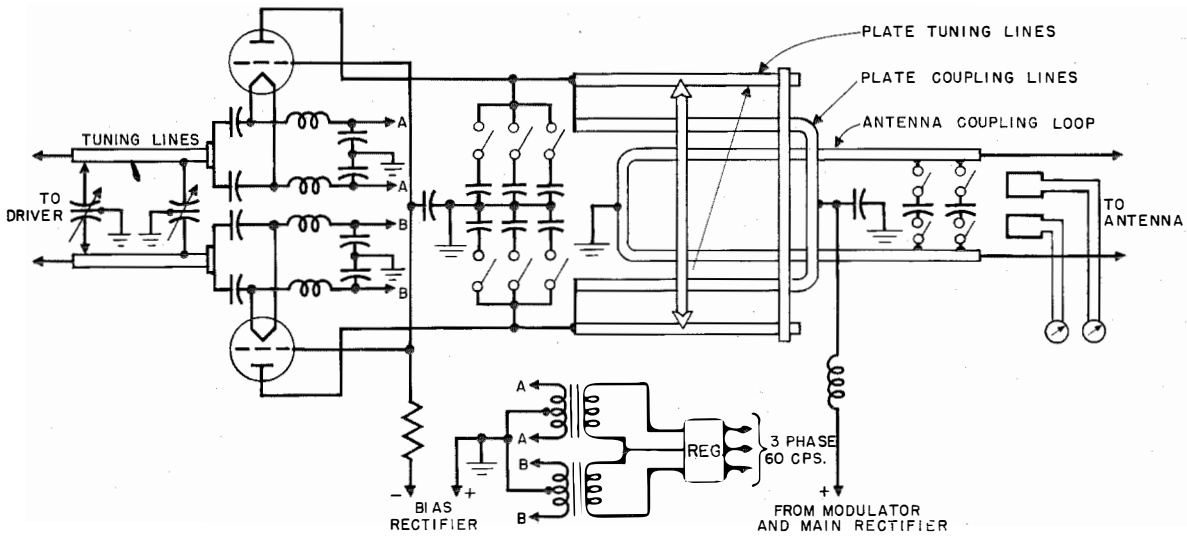

Fig. 4—Circuit of the 200-kilowatt amplifier. The pointed shorting bar may be shifted along the plate tuning lines by a motor-driven belt.

and provides coupling to the antenna pick-up loop which pivots up or down directly below it. The plate-circuit inductance lines carry the plate-cooling water. These circuit elements may be seen in Fig. 6.

Vacuum capacitors of 100 micromicrofarads were specially designed to provide the required plate-circuit capacitance. These capacitors have small tantalum filaments which may be operated occasionally to maintain a high degree of vacuum. They are switched into the plate circuit by means of manually operated switch blades designed to carry the radio-frequency current. No variable capacitors are used in the plate circuit, and all fixed capacitors may be disconnected from the plate to minimize the residual plate-to-ground capacitance when operating at the highest frequencies.

The position of the variable capacitor along the input line is indicated by a counter operated by a selsyn motor, the driver selsyn being coupled to the motor-operated driving mechanism. The positions of the plate tuning carriage and of the antenna pick-up loop are also indicated by means of counters on the front panel coupled by means of selsyn motors to their respective driving mechanisms. All driving motors are operated from 230-volt three-phase supply.

### 8. Audio-Frequency Units

The audio-frequency equipment receives energy from the line amplifier equipment in the control room at a level of about 10 vu and amplifies this to a maximum output of 150 kilowatts from the modulator stage. This equipment is divided into a low-power unit, an intermediate amplifier unit, and the modulator unit. Fig. 7 shows a schematic circuit of the audio-frequency equipment and indicates the tube types used. Alternating current is used for all filament or cathode heater circuits. Push-pull circuits are used throughout, with three separate negative feed-back loops as shown to attain a satisfactory degree of harmonic suppression with good stability.

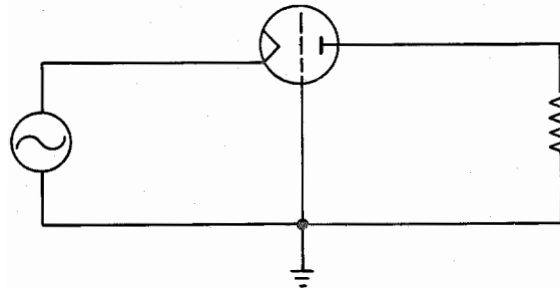

Fig. 5—Grounded-grid amplifier circuit.



The modulator, shown in Fig. 8, is designed to use six Federal F-125-A tubes for full output of 150 kilowatts. When modulating only the two 50-kilowatt power amplifiers, 4 tubes are employed. The tubes are operated class AB1 (without grid current). Bias can be adjusted individually for each tube from the front panel. The connections to the source of excitation voltage are such that the excitation to each tube is adjusted simultaneously and in proportion to the bias used.

The overall response of the audio-frequency amplifier-modulator equipment is within 0.5 db of the 1,000-cycle level from 30 cycles to 10,000 cycles. Harmonic distortion is less than 5 percent from 50 to 7,500 cycles at 95 percent modulation.

**9. Power-Frequency Equipment**

Power for the entire station is obtained from 2,300-volt, 3-phase, 60-cycle underground feeders leading from an outdoor transformer station

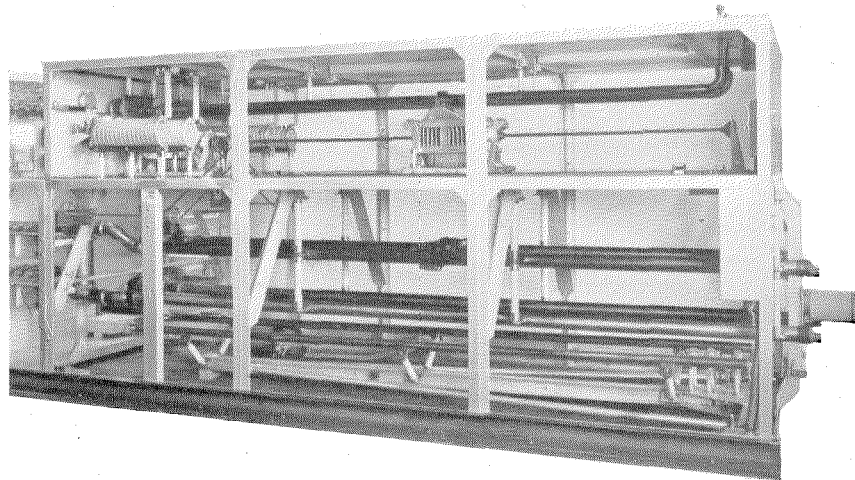

Fig. 6—Side view of the power amplifier. The plate and antenna tuning inductances, which are pairs of parallel copper pipes, are in the lower section of the frame. The input pipes are in the upper part with the travelling tuning capacitor at the center. The filament radio-frequency chokes, each capable of carrying 600 amperes, are at the upper left and were machined from a piece of copper pipe.

near the building. These feeders terminate in enclosed-type disconnect switches located in both vaults, thence the power is distributed through oil circuit breakers to induction regulators feeding the main rectifier plate transformers and the 2,300/230-volt transformer banks supplying power for all auxiliaries, filaments, and low-power equipment. Voltage to the 230-volt transformers is automatically regulated to assure constant voltage for the filament circuits.

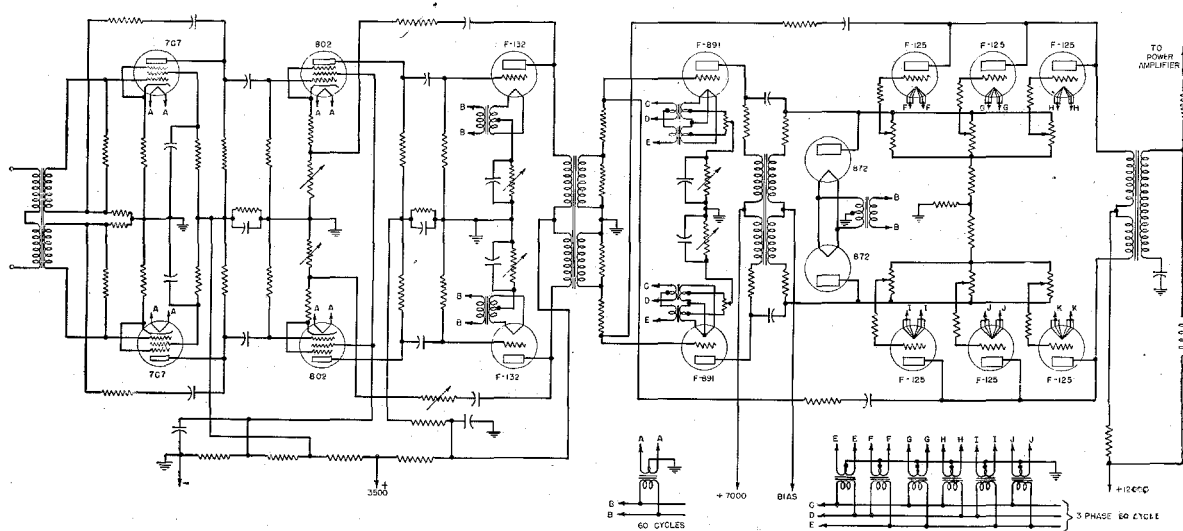

Fig. 7—Circuit of the 150-kilowatt modulator. Two of the final-stage tubes may be disconnected when only the 50-kilowatt transmitters are to be modulated.

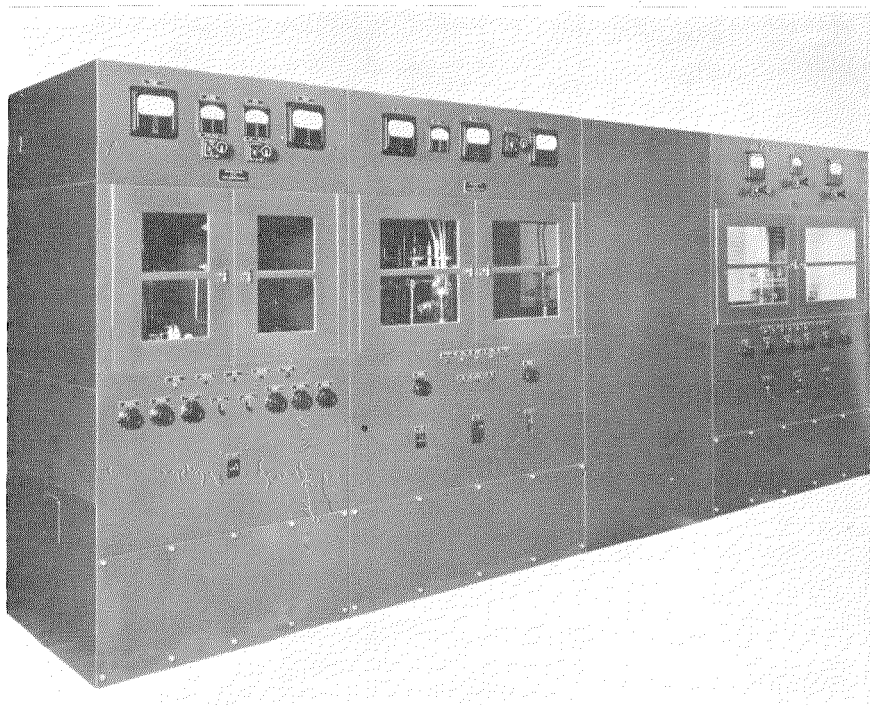

Fig. 8—Audio-frequency amplifier and modulator units.

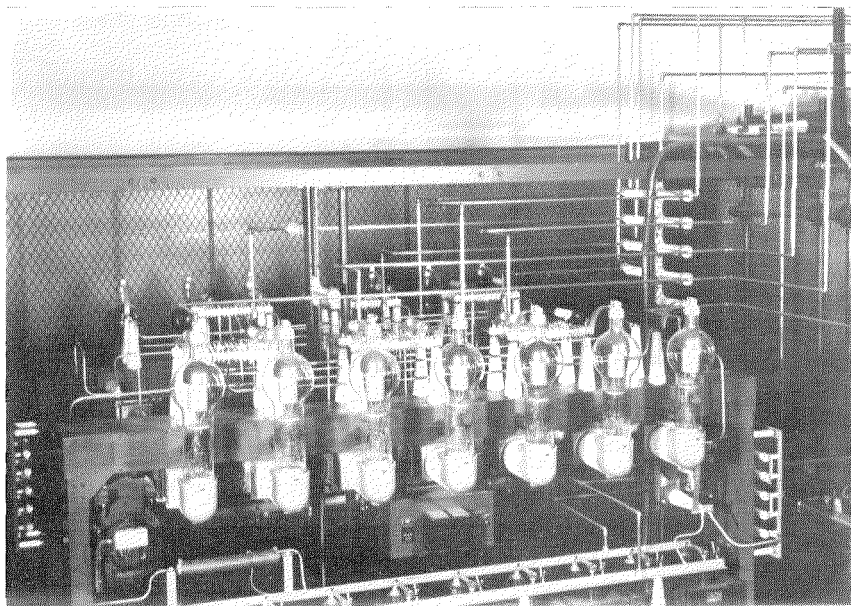
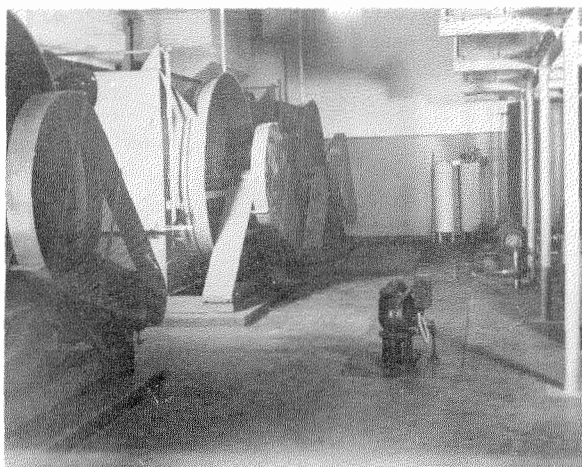

Fig. 9—Main rectifier. A second rack of tubes may be seen directly behind those in the foreground.

Power from the 230-volt transformer banks is distributed by the power-distribution units in which are mounted switches of the circuit-breaker type with magnetic trip-out features which open the switch on an overload. Power-control switches on the individual units are also of this type, so that no fuses are necessary for overload protection.

The main rectifiers, supplying 12,000 volts to the 50-kilowatt and 200-kilowatt amplifiers, employ a 3-phase, full-wave rectifier circuit. Six Federal F-857-A mercury-vapor rectifier tubes are used in this rectifier when supplying power for two 50-kilowatt transmitters. A second bank of six F-857-A tubes is required when the rectifier is supplying power for the 200-kilowatt transmitter. The transformer bank is connected in delta-delta to permit operation at reduced power in the event one of the transformers must be removed for servicing. An additional F-857-A tube (in a stand-by position) is included with each group of six rectifier tubes, to be used on failure of one of the active tubes.

The voltage from this rectifier is varied by means of the motor-operated induction voltage regulator in the 2,300-volt primary supply.



*Fig. 10—Three of the heat exchangers in the cooler room. A sump pump is in the center foreground. Water-conditioning equipment, a storage tank, and circulation pumps are at the rear right.*

This regulator may be controlled either manually or automatically, the range of the rectifier output voltage being from 8,000 to 12,500 volts. When automatically operated, it returns to its lowest position when the primary circuit breaker is opened, so that when the circuit breaker is closed the rectifier will start at a reduced voltage and slowly climb to any predetermined value.

### 10. Cooling Apparatus

The water cooling system is of the closed circulation type with radiator-type heat exchangers using large motor-driven fans. Each side of the station is equipped with a group of three parallel heat-exchanger units, only two of which are needed at a time to provide ample cooling for a complete 200-kilowatt transmitter. Normally, all heated air is exhausted through louvres in the outside walls of the building, but a portion of this air may be deflected into the building for heating purposes. The transformer vaults are ventilated by means of vent fans under the control of thermostats which operate to keep the ambient temperature within safe limits. Cool air is drawn in through louvres in the outside walls.

Forced-air cooling of the 200-kilowatt power amplifier and of the modulator and audio-frequency amplifier stages is provided by blowers

located in the cooler room. Filtered air, under pressure, travels through the cable trenches to the transmitter units and is finally exhausted through a vent fan in the ceiling of the transmitter room.

### 11. Control System

The control system has been made as simple as possible consistent with adequate safeguards against overloads and improper sequence of operation. All controls are operated by 230 volts, alternating current, and are interlocked so the equipment cannot be started in wrong sequence. Series, or two-wire, control is centered at the transmitter control panel, but is duplicated in major functions at the individual units.

Electrical interlocking door switches ground all circuits of dangerous voltage prior to the opening of access doors. Numerous pilot lights on the control panel and on the individual units indicate the functioning of various control and interlock circuits and facilitate the location of faults in operation.

To protect against damage from flash-over in the radio-frequency circuits and antenna system, a cut-off device interrupts the carrier momentarily if the average carrier level rises or falls more than a few percent from the predetermined value. A breakdown in any radio-frequency circuit will thus cause a low-power stage to be disabled momentarily, and if the resultant interruption of excitation to the higher-power stages fails to clear up the fault, the cut-off device will continue to recycle until the operator shuts down the equipment.

### 12. Conclusion

The international broadcast transmitters at both the Dixon and the Delano stations are now operating about 20 hours per day. Nearly all of this time is taken by broadcast material specially prepared by the Office of War Information. By reversing the directivity of some of the beam antennas, broadcasts are also made to South America.

In the design of the equipment, ample margin of safety has been stressed to assure uniformly high performance free from interruptions resulting from equipment failure. There has been no

sacrifice in flexibility, however, the motor-operated tuning controls in the 200-kilowatt power amplifier being particularly useful in making rapid changes of frequency. The basic design of the power amplifier, though departing in several important respects from that of more-conventional lower-powered amplifiers, is entirely practical and highly efficient. The use of several large tubes in parallel in the modulator has also proved to be practical, the actual performance of these units meeting all requirements for which they were designed.

The installation and test of this equipment

was made with the assistance of engineers from the Columbia Broadcasting System and the National Broadcasting Company at their respective stations. Grateful acknowledgment is due to Mr. J. O. Weldon, Chief of the Communications Facilities Bureau, and Mr. Charles Jeffers of the Office of War Information; to Mr. Robert DeHart and Mr. H. Anderson of the Columbia Broadcasting System; and to Mr. Raymond Guy and Mr. Carl Dietsch of the National Broadcasting Company for their assistance in the many problems connected with the installation and test of this equipment.

# Army Air Forces' Portable Instrument Landing System

By SIDNEY PICKLES

*Federal Telecommunication Laboratories, Inc., New York, New York\**

**S**HORTLY before Pearl Harbor, the Army Air Forces became interested in a portable version of the aircraft instrument landing system developed by Federal Telephone and Radio Corporation.<sup>1</sup> Immediately thereafter, the interest became a pressing demand which also involved the rapid development of an equi-signal glide path, the then-existing constant-intensity type being unsuitable.

## 1 Requirements

The main requisites of the portable system were:

- a. Portability
- b. Dependability
- c. Simplicity
- d. Ready Operation at 6 Frequencies: 108.3, 108.7, 109.1, 109.5, 109.9, and 110.3 Megacycles
- e. Air Transportability (Especially the Glide-Path Equipment).

Portability demanded that the system be demountable. Plug connectors were, therefore, required; also solid-dielectric radio-frequency transmission lines in place of the gas-dielectric type formerly used.

## 2 Transmission Line

The Intelin Division of Federal Telephone and Radio Corporation developed a solid-dielectric, low-loss, dual, shielded, 125-ohm transmission line<sup>2</sup> suitable for operation up to and including the very-high-frequency spectrum. Fig. 1 shows a completed interconnecting line with terminals and associated fittings. Type AN connectors were found with electrical characteristics sufficiently similar to those of the line as not to cause any appreciable electrical disturbance.

\* Formerly Federal Telephone and Radio Laboratories, Inc.

<sup>1</sup>H. H. Buttner and A. G. Kandoian, "Development of Aircraft Instrument Landing Systems," *Electrical Communication*, v. 22, n. 3, p. 179, 1945.

<sup>2</sup>N. Marchand, "Special Aspects of High Frequency Flexible Balanced Cables," *Electrical Communication*, v. 22, n. 3, p. 193, 1945.

The development of a satisfactory solid-dielectric transmission line is one of the greatest advances in the art, providing for greater dependability and flexibility as well as contributing largely to portability through demountability.

## 3 Localizer

The localizer permits the pilot to align the airplane with the runway on which the landing is to be made. It is the first "contact" with the landing system and must be very definite and unambiguous. That portion of the system will now be considered.

### 3.1 BROAD-BAND ANTENNAS

Although not requested by the Army, it was clearly realized that operation and maintenance problems would be greatly lessened if the antennas and mechanical modulator operated satisfactorily over the assigned frequency range without readjustment. A very determined effort was put on this part of the project. In the final equipment, a change of frequency merely requires a change of crystal, the adjustment of four tuning controls in the transmitter, and a check on the course alignment.

The loop antennas developed to meet the broad-band requirements were a modification of the type originated by Alford.<sup>3,4</sup> Fig. 2 shows the schematic electrical circuit. Fig. 3 illustrates a finished loop. The radiating elements have comparable width and length dimensions. Also, the maximum over-all dimension of the loop is close to 1/2 wavelength. The large radiating elements prevent substantial reactive component changes in the total impedance of the antenna as a result of frequency changes while the over-all dimensions, being comparable to a wavelength, increase the total radiation resistance. These two factors combine to produce an electrical system having broad-band characteristics.

<sup>3</sup>A. Alford and A. G. Kandoian, "Ultra-High Frequency Loop Antennae," *Electrical Communication*, v. 18, p. 255, April, 1940; and *Trans. Amer. Inst. Elec. Eng.*, 1940.

<sup>4</sup>A. Alford, U. S. Patent 2,283,897.

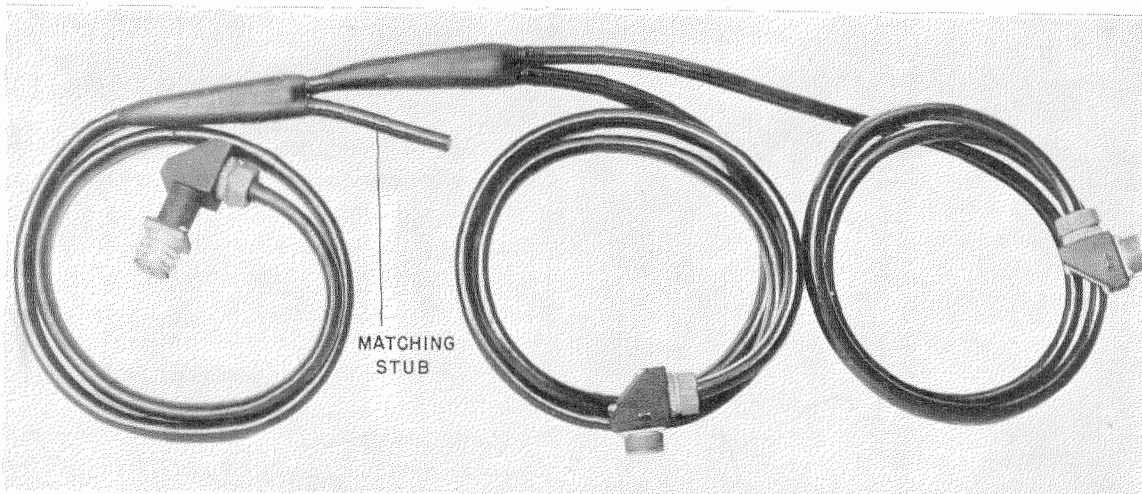

Fig. 1—Solid-dielectric flexible-cable assembly for the side-band radiators of the localizer antenna array.

The broad-band loop has another desirable feature. Normal loops require external tuning devices, such as stubs, to match their impedance to the transmission lines. However, the input impedance of the radiating elements of the broad-band loops is such ( $465 -j130$  ohms at the mid-frequency) that the short sections of transmission line connecting the loop input with the two input corners of the radiating elements could be used to transform the two unreal impedances to a real value of 125 ohms at the mid-frequency.

The capacitance of the supporting insulators at the far ends of the radiating elements prevented maximum current being produced at the center of the elements. To control this current distribution and thus obtain a nearly circular pattern, inductive loading stubs were connected across the loop corners opposite to the feed corners. These were housed in the crossarms of the loop support not used for the feed lines. The impedance characteristics of the loop as a function of frequency are shown in Fig. 4 and radiation characteristics in Fig. 5.

As mentioned in previous articles, the advantages of loop radiators over other more conventional types are many:

a. From each antenna signals are directed equally in all directions; no deep nulls result from individual antenna characteristics. This important factor contributes to the prevention of uncontrollable false courses.

b. The omnidirectional characteristics of the loop simplifies array pattern calculations thus expediting design.

c. The polarization of radiation is pure, tending to reduce course "push" which is discussed in Appendix II.

### 3.1.1 Array Design

Five loop radiators are arranged in a main group and an auxiliary group, to produce the radiation pattern of Fig. 6. This arrangement

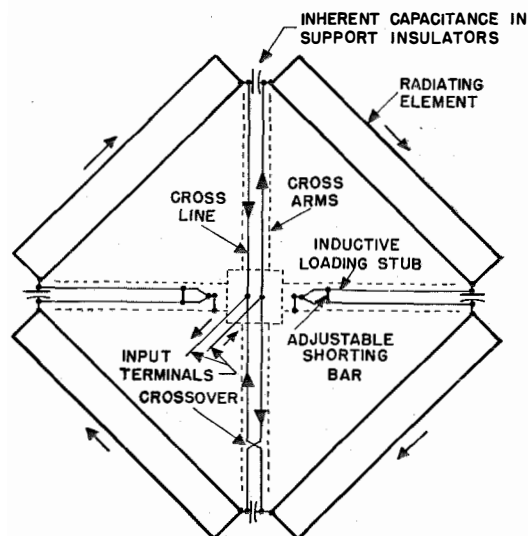

Fig. 2—Schematic circuit of the broad-band loop. Arrows parallel to loop elements indicate direction of current at a given instant.

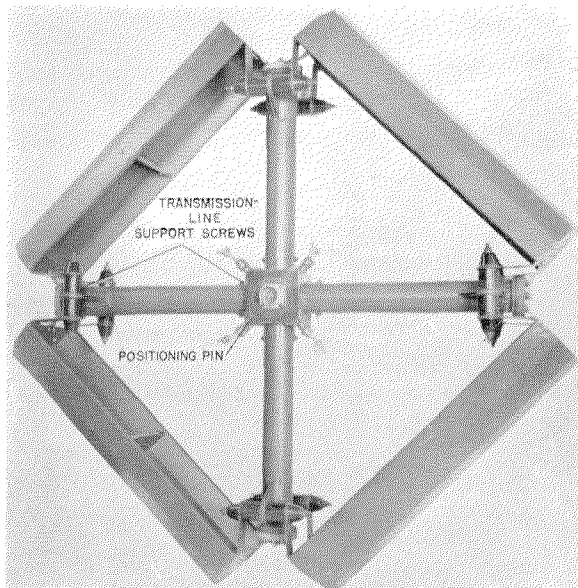

Fig. 3—Bottom view of loop.

gives maximum sharpness for a minimum of over-all array base length. The course sharpness is very nearly 3 decibels for a 1.5-degree deviation each side of the course line.

The formation of the localizer patterns is obtained in what may now be termed an almost-conventional manner. However, an approach to the general theory of localizer patterns given in Appendix I differs somewhat from previous presentations. The method of course shifting is also described in this appendix.

### 3.1.2 Phasing Problems

Operation of the equipment on several frequencies added one problem not encountered in a fixed system, namely, the over-all electrical length of the transmission lines relative to each other. The distance from the radio-frequency source to each antenna varies considerably. The longest cable is about 2.6 wavelengths. A cable 1 wavelength long at 108.3 megacycles increases in length about 8 degrees at 110.3 megacycles. Therefore, a cable 2.6 wavelengths long increases about 21 degrees. Assuming the shortest cable to be  $\frac{1}{2}$  wavelength long, the difference in final phasings between the two antennas at the end of each cable could be as much as 17 degrees.

This could result in a shifted course, a less-sharp course, or low clearance. The problem was easily overcome by cutting all cables to within about  $\frac{1}{4}$  wavelength of each other in length.

Further to insure the phase relations in the system, the entire array and its base were made of steel which would not change the shape or spacings of the antennas regardless of time or weather conditions. The whole array was mounted on the roof of an Army type K53, 2½-ton van-body truck as shown in Figs. 7, 8, and 9. All antenna equipment is stored on the roof of the truck during transport.

Fig. 10 shows a schematic wiring diagram of the radio-frequency system from the input of the mechanical modulator to the 5 antennas. It will be noticed that the lines which divide into Y's have open-ended corrective stubs to compensate for the 2/1 mismatch produced by paralleling the lines at the Y junctions. Electrical control of the course is provided by the phasing unit in the line which feeds the auxiliary radiators. This unit is housed in the modulator cabinet.

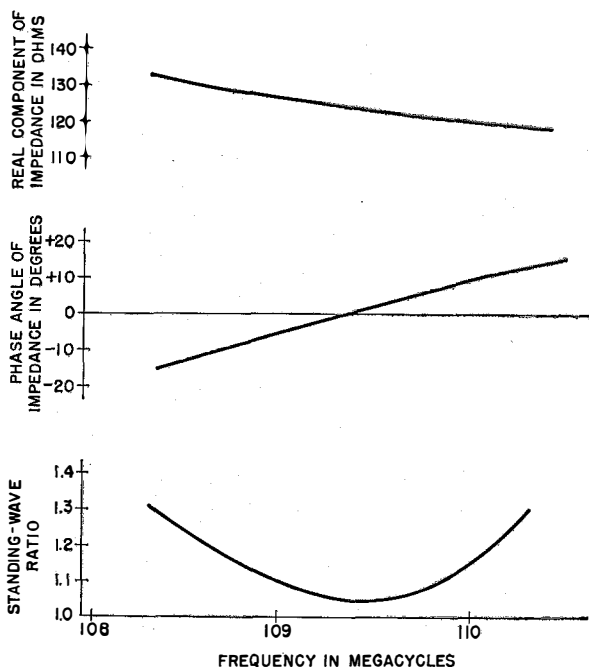

Fig. 4—Real component and phase angle of impedance and standing-wave ratio plotted against frequency for the broad-band loop.

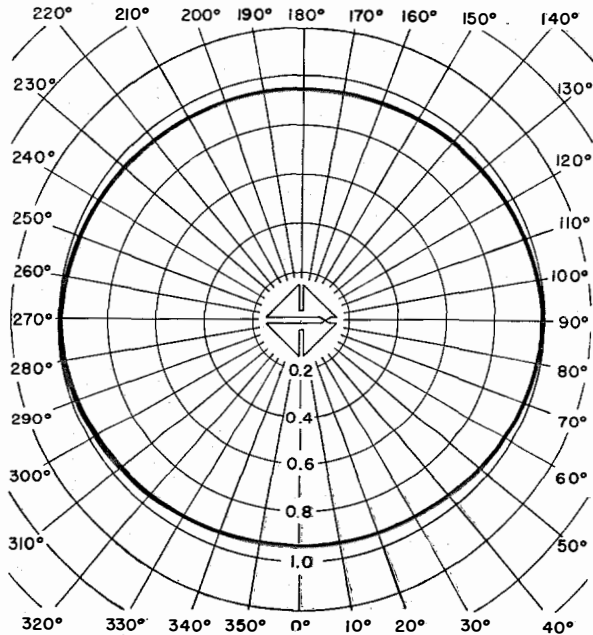

Fig. 5—Radiation characteristics of loop.

### 3.2 MECHANICAL MODULATOR

One of the main differences between a localizer and a radio range is the need for much greater dependability and course accuracy. A radio range course, in most cases, may shift a few degrees and still not result in hazardous flying. In an instrument landing, an aircraft is continually decreasing its distance from the ground thereby getting into hazardous regions where accurate and dependable guidance is imperative. The prewar development of the mechanical modulator, which avoids the use of electronic devices where their vagaries and failures are of critical importance, was an outstanding contribution to a practical instrument landing system.

For the portable system the mechanical modulator met all requirements admirably. Not only was it free of electronic devices but it was also free of tuning adjustments. With the mechanical modulator, failure of one of the transmitter output tubes results in no noticeable change in the course. This particular mechanical modulator, which has no moving contacts, brushes, or similar accessories, separates and

phases carriers and side bands so that one array, rather than two, will produce the desired overlapping patterns. Fig. 11 shows a front view of the modulator. The principle of its operation is more thoroughly described in Appendix III.

A phasing unit for controlling course location is housed in the same cabinet with the mechanical modulator. It, also, has no moving contacts and similarly has given absolutely no trouble in service. It works on the principle of dielectric phase delay along a transmission line and is discussed more thoroughly in Appendix III.

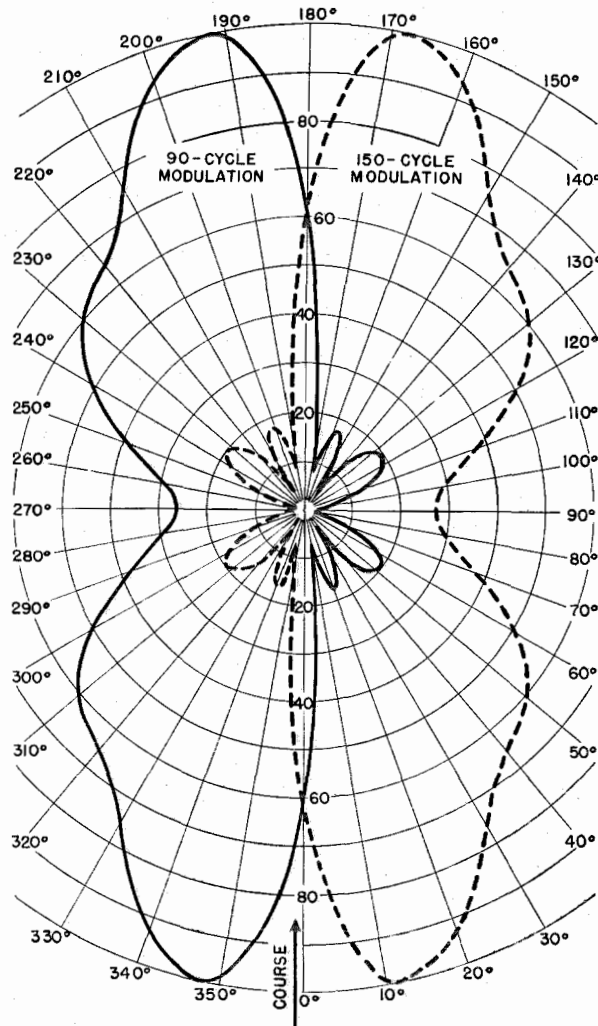

Fig. 6—Radiation pattern of the 5-loop array used for the localizer.



### 3.3 TRANSMITTER

The transmitter is of the balanced-output type and of conventional design. The radio-frequency, power-supply, and modulator sections are mounted in a cabinet on rollers one above the other as shown in Fig. 12. Such construction makes for compactness as well as ready access for maintenance purposes. Included in the modulation section are a 1020-cycle oscillator and automatic keyer to provide an identification signal. Voice modulation can be readily obtained but course modulation is automatically turned off during voice transmission.

### 3.4 MONITOR

When the localizer is in operation, the course is continually checked by the monitor shown in

Fig. 13. The monitor consists of a detector followed by an audio amplifier, 90- and 150-cycle filters, rectifier, and course-indicating instrument. The audio-frequency filters and rectifiers are standardized for all elements of the landing system including the aircraft receivers and accessory equipment. Any change in the course, persisting for a few seconds, causes the monitor to remove the plate voltage from the transmitter, rings a warning bell, and turns on warning lights in the indicator box located inside the truck.

### 3.5 TEST EQUIPMENT

Several pieces of test equipment have been built to assist in adjustment and analysis. A portable course detector has proved to be the most useful and will be the only one mentioned

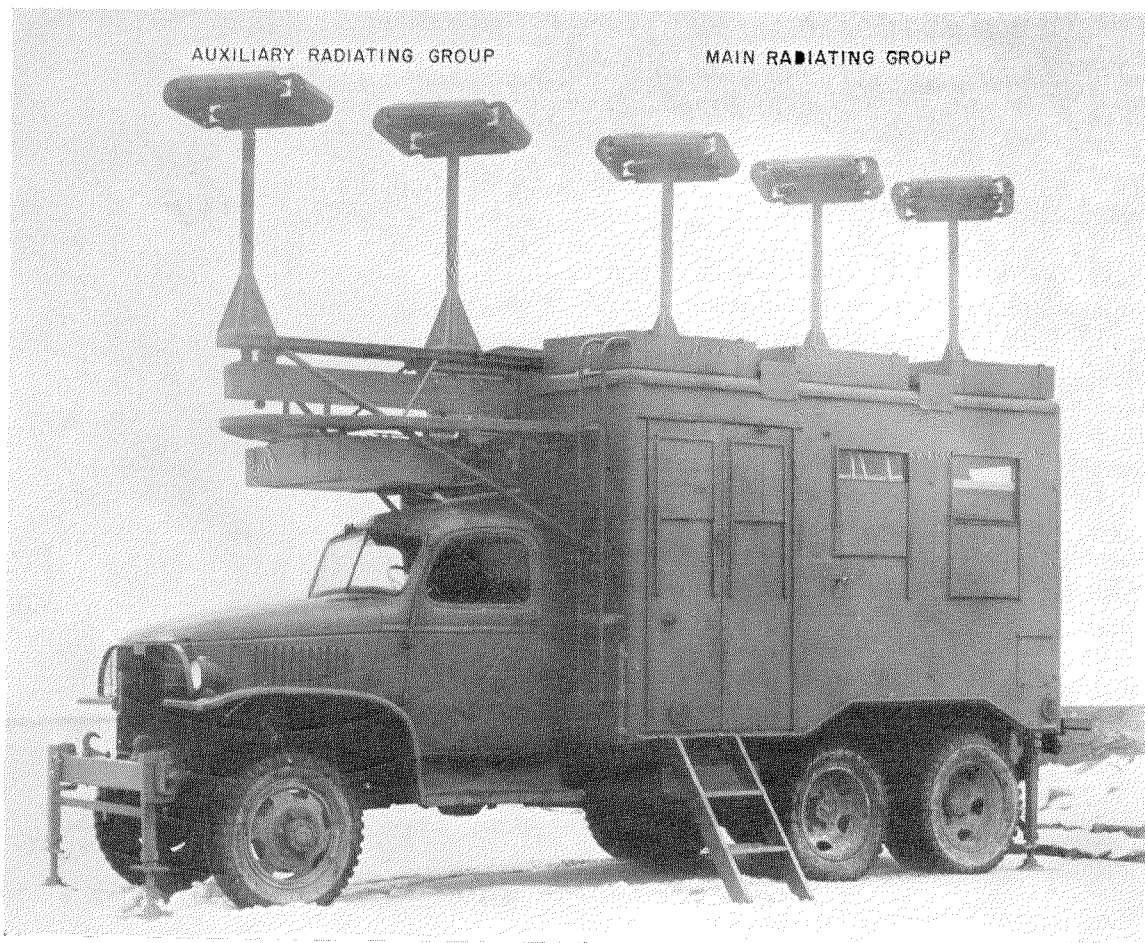

*Fig. 7—Localizer truck with loops in operating position.*

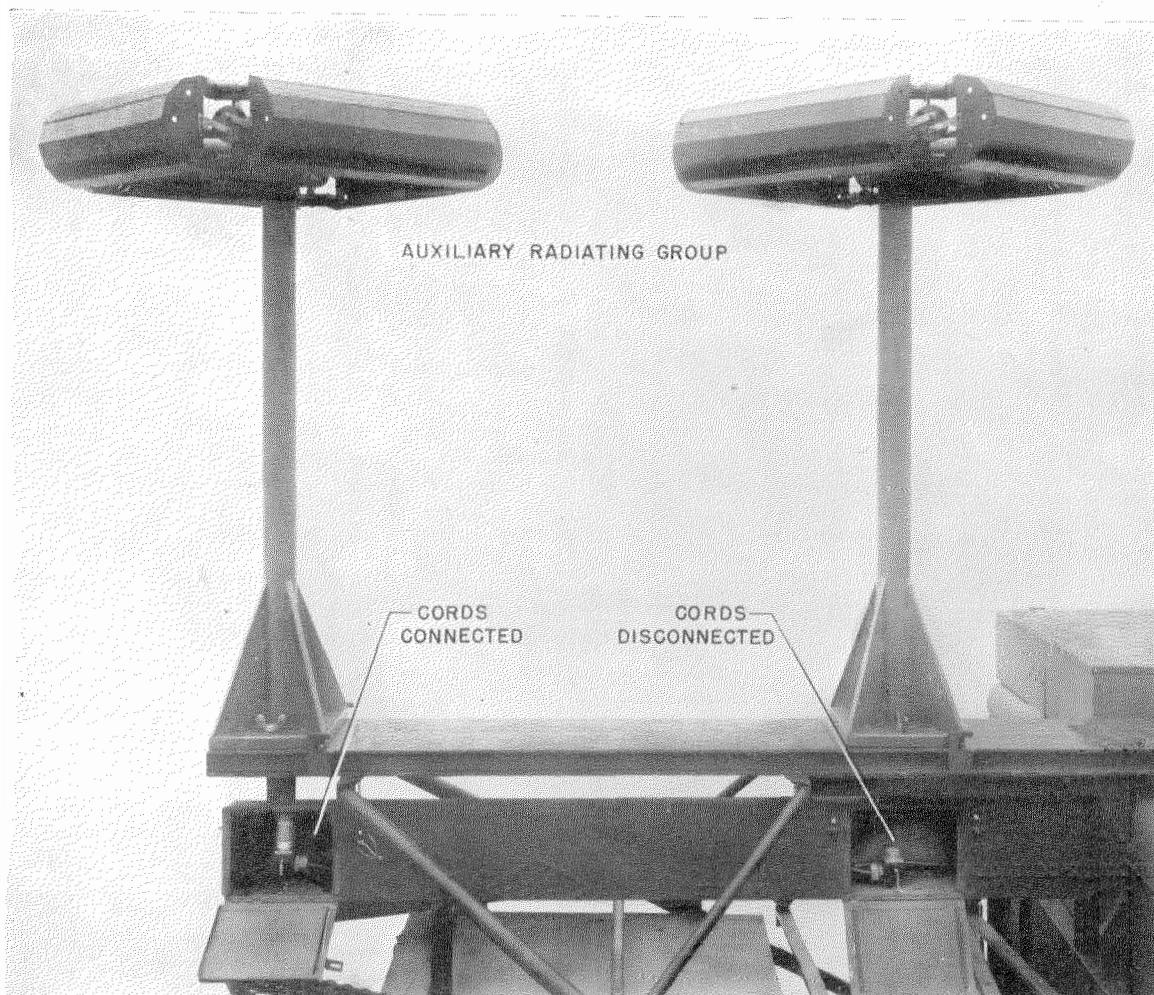

Fig. 8—Mounting arrangement of loops and of ducts in which connecting cables are run on top of truck.

here. This unit, shown in Fig. 14, consists of a dry-battery-operated superheterodyne receiver and audio amplifier. Following the audio amplifier is a standard filter and rectifier system, the output of which can be switched to the indicating instrument on the front panel of the unit. The switching means also makes it possible to measure the individual rectified filter outputs and clearances. In addition, radio-frequency signal levels and filter input voltages can be measured to determine radiation patterns, relative percentages of modulation, and many other useful quantities.

### 3.6 AIRCRAFT RECEIVER

The aircraft localizer receiver, built by Western Electric Company, is a crystal-controlled

6-channel superheterodyne type with an audio system, filters, and dry rectifier. The rectified output operates a course-indicating instrument shown in Fig. 15 which is mounted on the aircraft instrument panel. Fig. 16 shows the nature of the indications produced in a horizontal plane about the localizer.

### 4 *Glide-Path System*

After the airplane has been aligned with the runway by utilizing the signals of the localizer, it must be guided in its descent to the ground. This vertical guidance is provided by the glide-path system.



Fig. 9—Localizer truck ready for shipment.

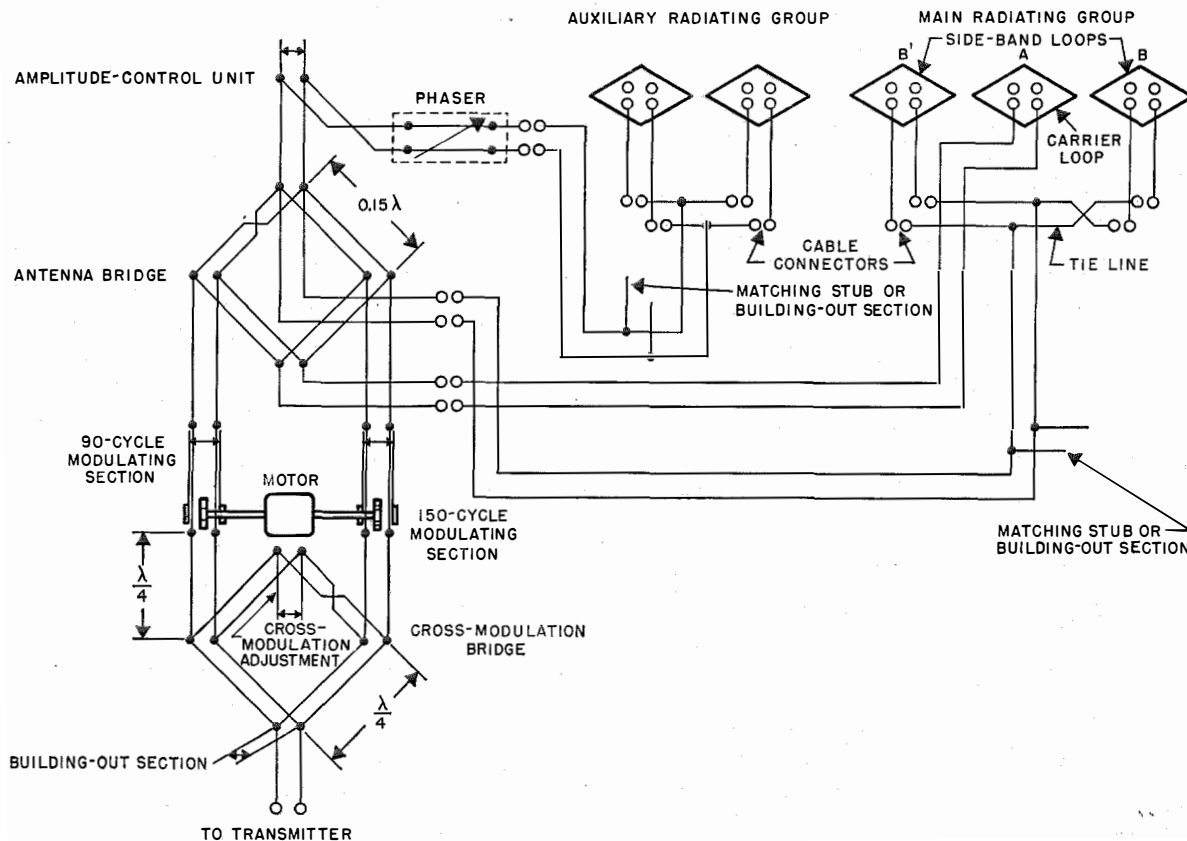

Fig. 10—Schematic diagram of mechanical modulator and radiating equipment for the localizer.

#### 4.1 PRINCIPLES

There have been many glide-path systems proposed for the instrument landing of aircraft. Nearly all of those which did not use the equi-signal principle had one or more of the following defects:

- a. Inability to produce a straight-line path more than a few miles in length.
- b. Lack of uniformity in glide-path angle from one airport to another and from one aircraft to another because of differences in transmitted energies or receiver sensitivities.
- c. Change of glide-path angle with attitude of the airplane in respect to the transmitting antennas.

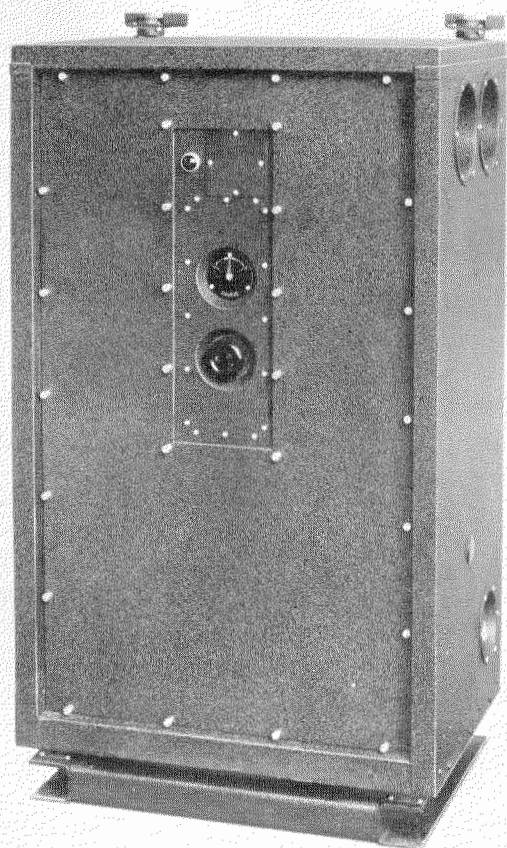

Fig. 11—Mechanical modulator cabinet.

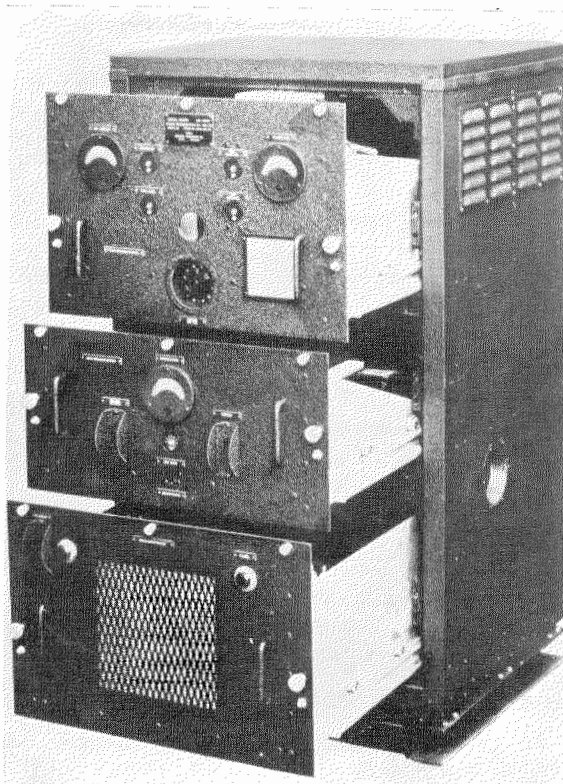

Fig. 12—The radio-frequency, power-supply, and modulator sections of the localizer transmitter are mounted in the three "drawers" shown above.

The equi-signal type of glide path has proved to be most free of these difficulties. A glide path or a course is produced in such a system by means of two overlapping radiation patterns, modulated by different audio frequencies. The aircraft receiver is equipped with filters which separate the respective audio modulations.

The path is defined as the region in which equal audio signals are produced in the receiver. With this type of glide path, the glide angle remains constant as far from the transmitting antennas as a usable signal can be received. From a military standpoint, the equi-signal glide path has another important advantage: the antenna system is much less complicated, more portable, and does not require as highly trained personnel for correct operation as did previous systems.

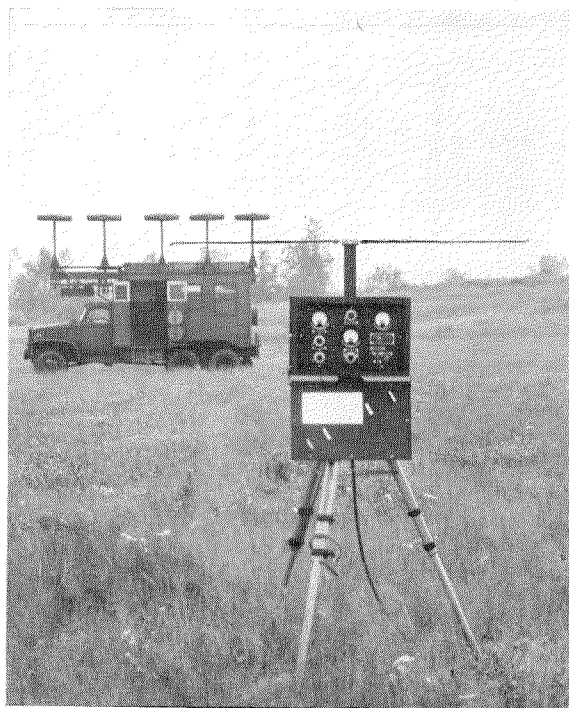

Fig. 13—Localizer monitor shuts down the transmitter and operates warning lights and bells if the course shifts. Provision is made to prevent a momentary shift caused by aircraft flying over the localizer from stopping operation.

#### 4.2 OBTAINING OVERLAPPING PATTERNS

If two antennas, which emit horizontally polarized radiations, are placed one above the other at considerably different distances from the ground, the lobes in the vertical pattern of the upper antenna may make several intersections with the fewer number of lobes in the vertical pattern of the lower antenna. The number of intersections will depend on the relative amplitudes of the signals fed to the antennas. Fig. 17 shows part of the vertical radiation pattern of two vertically spaced antennas. From this figure it can be seen that if the radio-frequency energy in each antenna is modulated with a different audio frequency, a course can be produced at an angle  $a$  with respect to the ground.

On the glide path under discussion, the radio frequencies used are 332.6, 333.8, and 335.0 megacycles per second. The radio-frequency energy in the lower and upper antennas is modulated at 90 and 150 cycles, respectively.

At these carrier frequencies, glide-path angles as low as 2 degrees can be obtained with upper and lower antenna heights above ground of approximately 28 feet and 6 feet, respectively. Both antennas are fed by balanced transmission lines of the Intelin type, similar to that used for the localizer. The optimum ratios between radiation amplitudes and heights of the upper and lower antennas was a compromise between; (a) sharpness of the "on-course" signal; (b) nearly equal minimum clearances, both below and above the course; and (c) the prevention of a false course at an angle less than 6 times the desired glide-path angle. The optimum values chosen are plotted in rectangular coordinates in Fig. 18.

Glide angles are adjusted by changing antenna heights while keeping the height ratios constant. This results in constant clearance values but varying path sharpness. Glide-path angles between 2 and 5 degrees are obtainable in  $\frac{1}{4}$ -degree steps up to 4 degrees and then by  $\frac{1}{2}$ -degree steps up to 5 degrees. The upper antenna has sufficient inherent vertical directivity to decrease by a small amount the radiation at angles above approximately 15 degrees. Therefore, clearances between the fourth lobe of the upper antenna and the first lobe of the lower antenna are somewhat greater than shown in Fig. 18 for glide angles over 3 degrees.

From Fig. 17 it can be seen that antenna heights are not the only factors in determining the glide-path angle; the amplitudes of the signals also must be considered. If the amplitude of the upper-antenna signal is increased appreciably, the glide-path angle is increased slightly to an angle of  $a_2$  and false courses occur at angles of  $a_3$ ,  $a_4$ ,  $a_5$ , and  $a_6$ . Such amplitude relations between upper and lower antennas are to be avoided. If the amplitude of the upper antenna were to be appreciably decreased from that shown by the solid line of Fig. 17, the first intersection of the upper- and lower-antenna lobes would be somewhat indefinite. Practically, if the first false path produces a glide angle 6 times that of the desired glide angle (the ratio of  $a'/a$ , Fig. 17) no confusion results.

#### 4.3 STRAIGHT-LINE GLIDE PATH

If the glide-path antennas have identical horizontal patterns (not necessarily circular), the

points of intersection between their first lobes will be at a constant angle above ground throughout the 360 degrees around the two antennas. Such an intersection of patterns is contained in the surface of a cone, Fig. 19A. It is, of course, to be noticed that the intersections are straight lines as far as the sides of the cone can be produced. The system has an image in the ground which is shown merely to conform with the mathematical expression presented in the figure.

All discussion so far has had to do with the nature of the glide path as extending out from the region on the ground directly below the two antennas involved. The lower part of such a glide path could not be used, as the equipment would form an obstruction; it has to be moved a considerable distance off the runway. The Army specifications required that a straight-line glide path be produced to the point of contact with the equipment located 400 feet,  $\pm 150$  feet,

from the center line of the runway. With the equipment located off the runway in this manner and with antennas having identical radiation characteristics, Fig. 19B shows that the glide path would follow a hyperbolic curve produced by the intersection of a vertical plane and the glide-path cone.

As was mentioned previously, the angle of the glide path can be changed by varying the ratio of the signal amplitudes from the upper and lower antennas. This variable permits the path to be made straight to the point of contact. Variation of signals from upper and lower antennas is obtained from the horizontal directivities built into the antennas. The expression  $R_1(\theta)$  in equation (3) of Fig. 20 can be made to vary as a function of  $\theta$  so that the amplitude ratios between the upper and lower antennas will be changed during the progress of the flight to produce a straight-line glide path. The

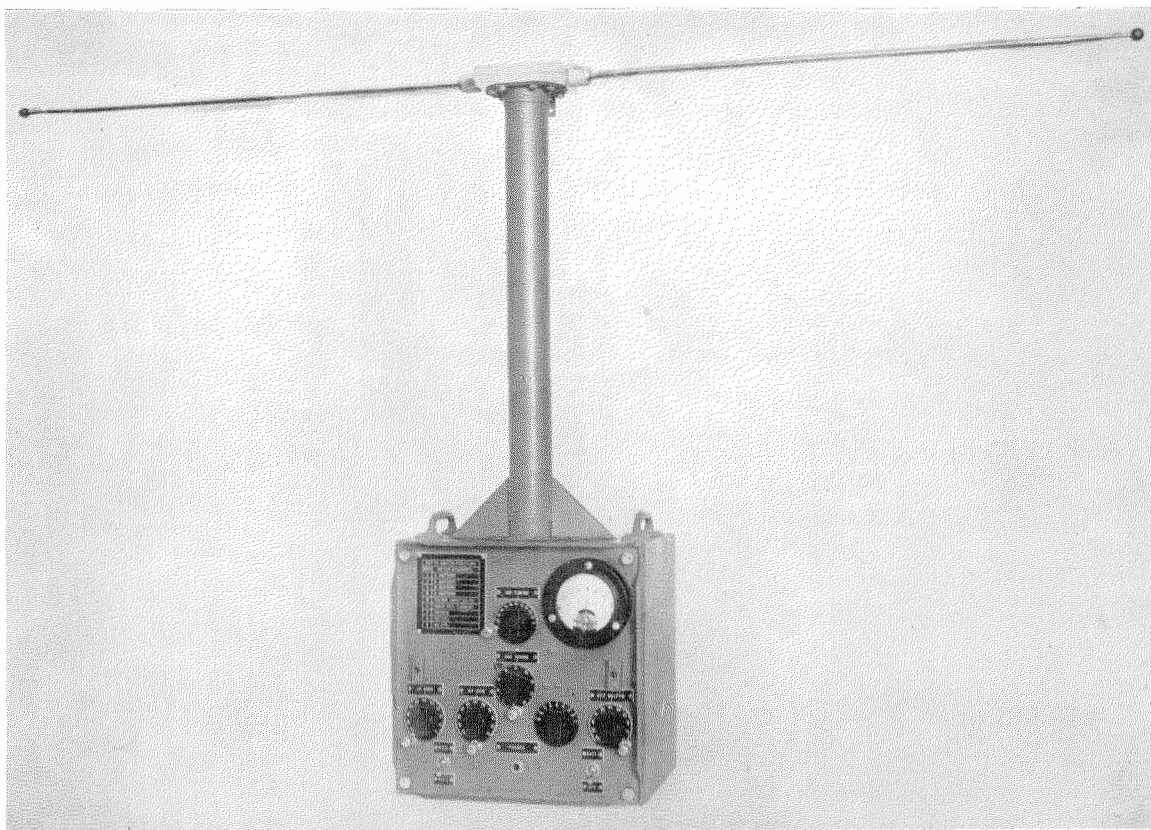

Fig. 14—The portable course detector is the most useful piece of test equipment in adjusting the localizer.

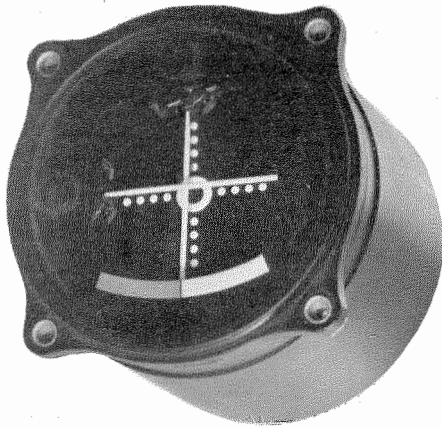

Fig. 15—The cross-pointer indicator is mounted on the instrument panel of the airplane. The localizer signals operate the vertical needle which is pivoted at the top; the horizontal needle is controlled by the glide-path radiations. The pilot follows the pointers up, down, or to the side to get on the landing path.

disadvantages of changing the previously determined amplitude ratio under these circumstances can be tolerated over the short portion of the path involved.

To determine the way in which the horizontal radiation characteristics and the glide-path antennas should vary to produce the straight-line path, it is necessary to know the relations existing between the various angles shown in Fig. 20. The vertical angle  $a$ , which the airplane subtends with respect to the earth when viewed from the glide-path equipment, also varies along the glide path as does the horizontal angle  $\theta$ . The tangent of the angle  $a$  is equal to the altitude of the airplane  $A$  at any point divided by the projected distance  $r$  of the airplane from the glide-path equipment. The glide-path angle  $\phi$ , by definition, has to be held constant throughout the length of the glide path. Therefore, the ratio of  $A/d$  is equal to a constant  $K$ . However,  $d = r \cos \theta$ , or  $r = d / \cos \theta$ . Therefore, the tangent of the vertical angle of the straight-line glide path, as viewed from the glide-path equipment, is equal to a constant times the cosine of the horizontal angle subtended. The glide-path angle in all cases is 5 degrees or less. Over this range of angles both the sine and tangent functions are nearly identical in value to the angles themselves when expressed as radians. The angle  $a$  is seen

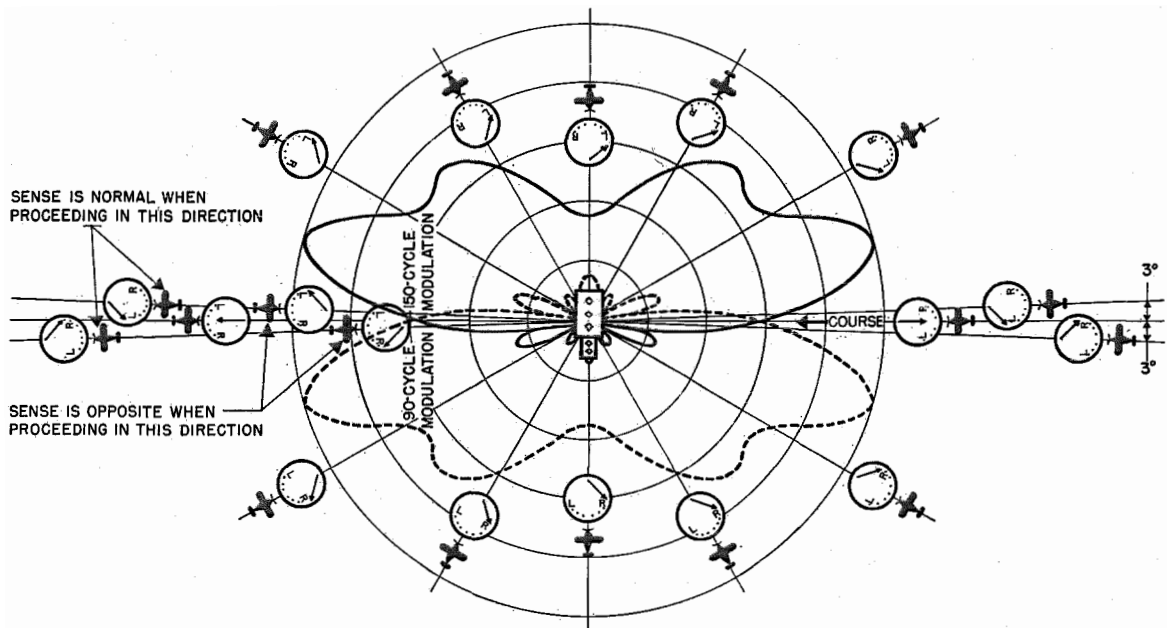

Fig. 16—Localizer course with figures showing indications in the aircraft.

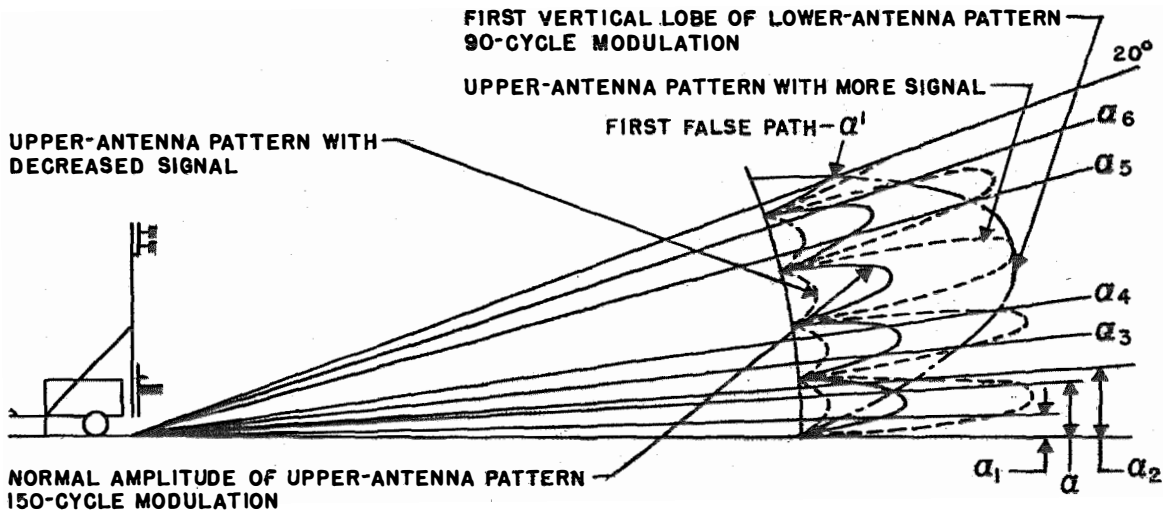

Fig. 17—Vertical pattern from 2 vertically spaced antennas showing true and false courses produced under several conditions of relative antenna powers.

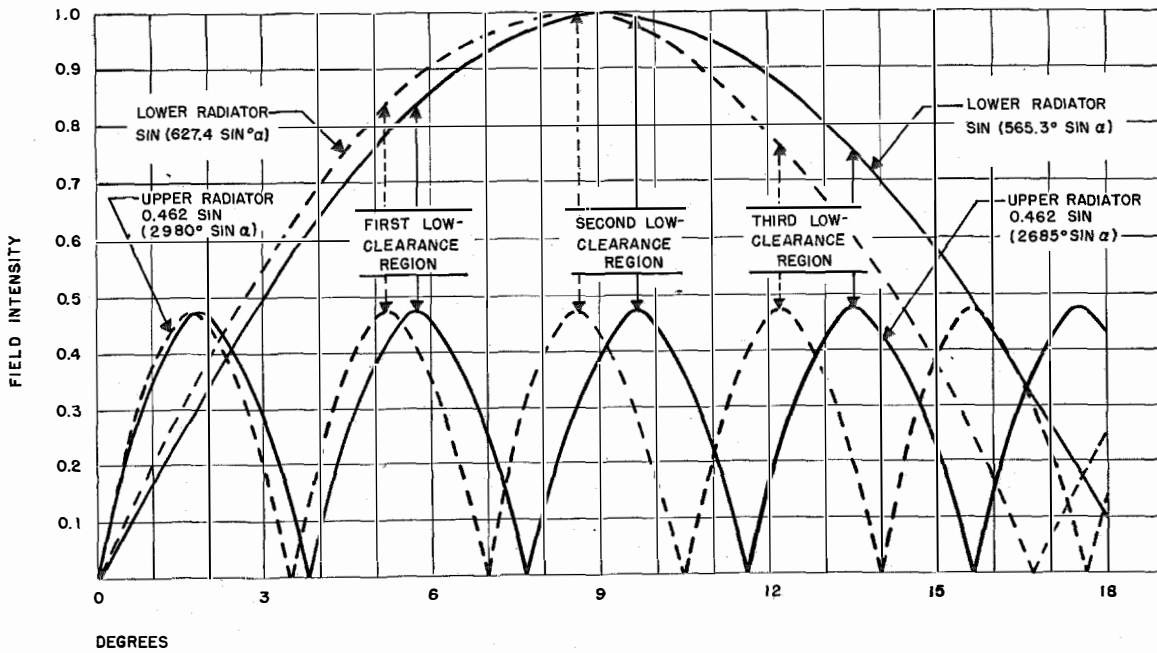
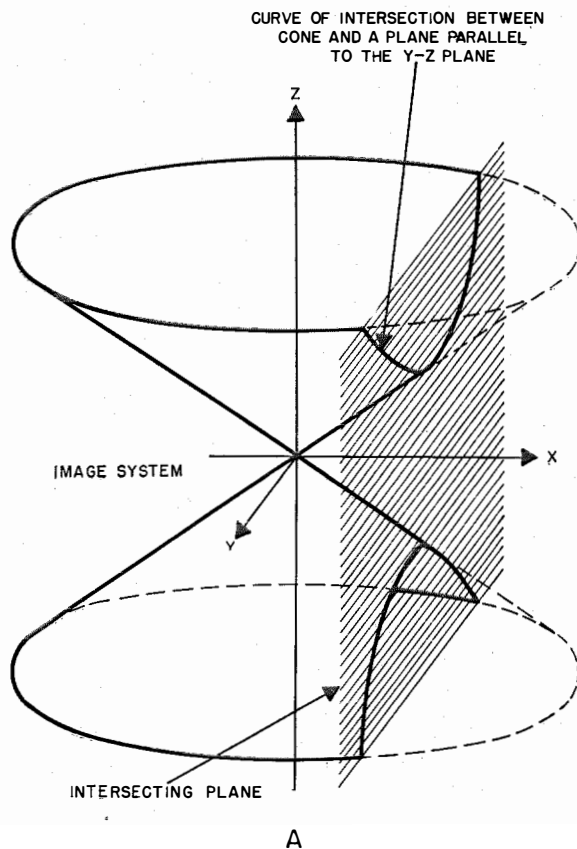

Fig. 18—Radiation patterns at vertical angles up to six times the glide-path angle of 2.5 degrees in solid lines and for a glide-path angle of 2.25 degrees in dotted lines.





Equation of Cone  $\frac{x^2}{a^2} + \frac{y^2}{a^2} - \frac{z^2}{c^2} = 0$ .

Equation of Straight Lines  $\begin{cases} \pm \frac{x}{a} = \pm \frac{z}{c}, & \text{when } Y=0. \\ \pm \frac{y}{a} = \pm \frac{z}{c}, & \text{when } X=0. \end{cases}$

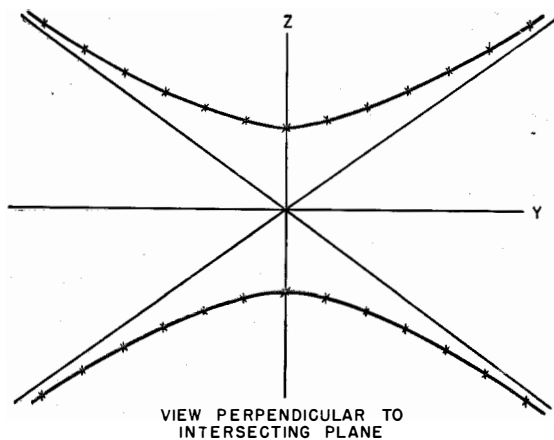

Equation of Hyperbola  $\frac{z^2}{c^2} - \frac{y^2}{a^2} = K$ , when  $x$  is constant.

Fig. 19—Theoretical basis of the glide path.

to vary from the small angle of the glide path to zero. There is no appreciable error in equating the angle  $a$  to  $(K \cos \theta)$  in equation (2) of Fig. 20.

It was previously pointed out that the glide path is defined as the point where the radiation intensities of the first lobes of the upper and lower antennas are equal, assuming equal percentages of modulation. Therefore, these two intensities can be equated when expressed as functions of the angle  $\theta$ . The ratio of one horizontal radiation pattern to the other horizontal radiation pattern must then be equal to the ratio of the sine functions of the angles resulting from the product of the antenna heights by the cosine of the horizontal angles swept through and the constant  $K$ . Equation (6), Fig. 20, expresses this final relation.

Using the value of antenna heights in electrical degrees shown in Fig. 18, the ratio expressed by equation (6), Fig. 20, was calculated and then plotted as the dotted line in Fig. 21. As the horizontal angle  $\theta$  increases from zero, the ratio of the amplitude of the upper antenna with respect to the lower antenna has to be decreased to reduce the angle  $a$  of Fig. 20. It is clear from equation (6), Fig. 20, that if the horizontal radiation characteristic of one antenna, for instance  $R_2(\theta)$ , were constant or of unit value, the ratio of the sine functions would then be the exact horizontal radiation characteristic required of the other antenna to produce a straight-line glide path. A loop antenna is known to provide an essentially circular horizontal radiation characteristic. An antenna of similar type was chosen for the lower antenna. The pattern of the final antenna is shown in Fig. 22. This pattern is nearly circular over a considerable region on each side of the zero angle, this being the perpendicular to the center of the screen. The dotted line in Fig. 21 was known to have a shape somewhat similar to that produced by a short "V" antenna system. The pattern produced by the final design of the upper antenna is shown in Fig. 23.

The two patterns of Figs. 22 and 23 may be oriented, with respect to each other, in any desired manner which will produce a ratio most nearly approximating the theoretical ratio shown in Fig. 21. When the zero-angle point of the

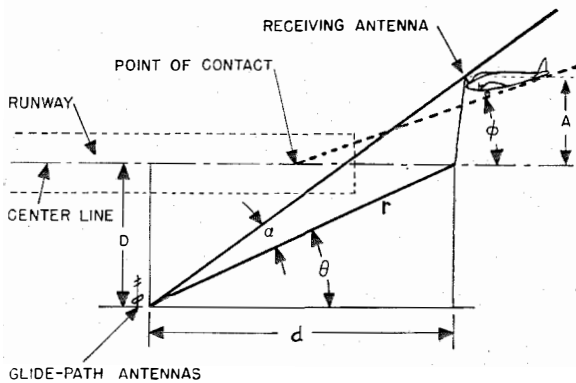

$\phi$  = Glide-path angle,  
 $a$  = Vertical angle subtended by airplane when viewed from base of glide-path mast,  
 $\theta$  = Horizontal angle between airplane and an "on-path" point at great distance as viewed from the glide-path antennas,  
 $r$  = Projected distance of airplane from glide-path antennas,  
 $d$  = projected distance of airplane from perpendicular between runway and glide-path antennas,  
 $H$  = Height of upper antenna from ground surface,  
 $h$  = Height of lower antenna from ground surface,  
 $F_1$  and  $F_2$  represent the signals from the upper and lower antennas,  
 $R_1(\theta)$  and  $R_2(\theta)$  are horizontal-radiation characteristics of the upper and lower antennas,  
 $\sin(h \sin a)$  and  $\sin(H \sin a)$  are vertical-radiation characteristics of the lower and upper antennas, respectively,  
 $\tan a = (A/r) = [(A \cos \theta)/d] = K \cos \theta$ ,  
 $\tan \phi = A/d = K$ .

Angle  $a$  varies from a small angle to zero so that  $\tan a = \sin a = a$  with negligible error,  $\therefore a = K \cos \theta$ . (1)

$F_1 = R_1(\theta) \sin(h \sin a) = R_1(\theta) \sin(hK \cos \theta)$ . (2)

$F_2 = R_2(\theta) \sin(H \sin a) = R_2(\theta) \sin(HK \cos \theta)$ . (3)

At all points on the glide path  $F_1 = F_2$ . (4)

$R_1(\theta) \sin(hK \cos \theta) = R_2(\theta) \sin(HK \cos \theta)$ . (5)

$\frac{R_1(\theta)}{R_2(\theta)} = \frac{[\sin(HK \cos \theta)]}{[\sin(hK \cos \theta)]}$ . (6)

Fig. 20—Production of straight-line glide path.

lower-antenna pattern of Fig. 22 is directed at the point of infinite distance on the glide path, a rotation of the upper-antenna pattern of approximately 12 degrees away from the runway results in a ratio closely approximating the theoretical ratio over a subtended horizontal angle of nearly 70 degrees.

The actual ratio shown in Fig. 21 is a little less than the theoretical value. If the rotation of the upper antenna is decreased to 6 degrees, the actual ratio is a little more than the theoretical quantity. In this case the glide path be-

yond an azimuth angle of about 10 degrees is a little less steep than it should be, thus approaching the hyperbolic form to a certain extent. Such a shape does not insure contact with the ground if the glide path is followed exactly and certainly does not insure that the glide path is beneath the ground for a distance beyond the point of contact with the runway, another Army requisite. For this reason the 12-degree rotation of the upper antenna with respect to the lower antenna has been chosen as the final orientation. Fig. 24 shows the final orientation of the horizontal radiation patterns of the lower and upper antennas.

#### 4.4 RADIATION SYSTEM DESIGN

##### 4.4.1 Lower Antenna

During the development of this system, a considerable amount of difficulty was encountered from reflections produced by the equipment associated with the antenna system. This was particularly true of the lower antenna which is located between 4 and 6 feet from the ground in the immediate vicinity of the transmitting equipment. Any vehicle or cabinets housing the transmitting equipment constitute reflecting surfaces. Fig. 25 shows the lower antenna which is essentially a loop radiator bisected by a screen, only

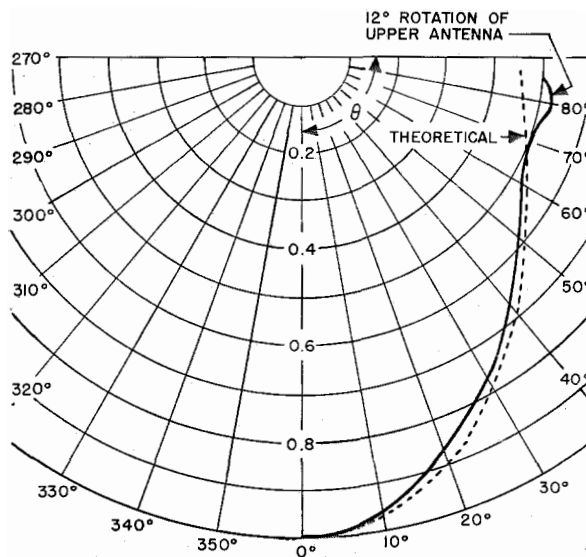

Fig. 21—Theoretically required and actual signal ratios between upper-antenna and lower-antenna radiation patterns.

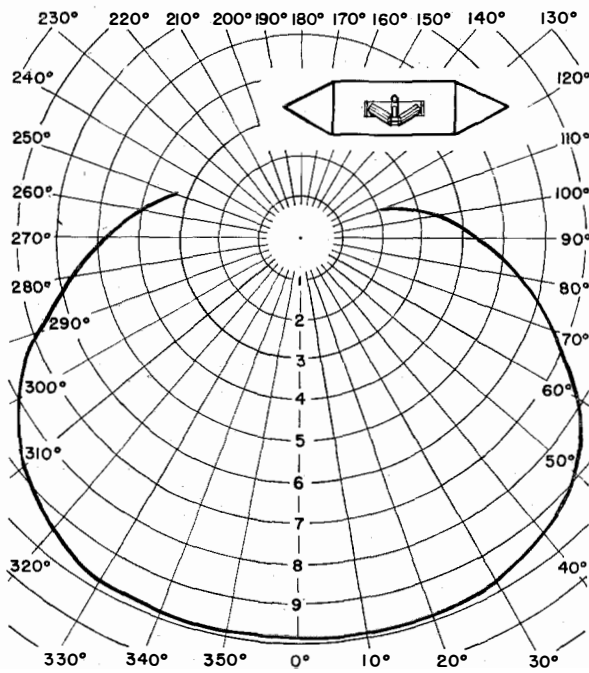

Fig. 22—Horizontal radiation characteristic of the lower antenna.

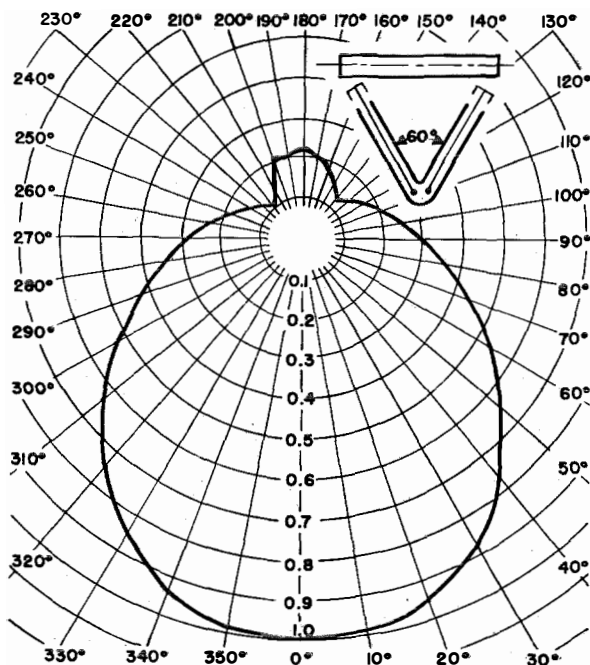

Fig. 23—Horizontal radiation characteristic of the upper antenna.

the front half of the antenna remaining for use. This antenna produces a nearly constant horizontal radiation for a considerable region on each side of the perpendicular to the plane of the screen at the center of the antenna. The screen shields the equipment to the rear avoiding troublesome reflections from that direction and also increases the radiation along the glide path.

Radiations traveling from an exciting source near the middle of a short screen have a considerable amount of energy when reaching the ends of the screen, which constitute discontinuities with resulting reflections of energy flow. The points of discontinuity act as new radiating sources. The radiator in front of such a screen has its radiation characteristics modified other than by a pure image induced in the screen. The shape of the ends of the screen influence substantially the antenna pattern. The tapered ends of the screen shown in Fig. 25 produced the most nearly circular pattern over the largest horizontal angle.

The input impedance of the radiating elements of the lower antenna of Fig. 25 is nearly a pure resistance of approximately 350 ohms. This impedance is transformed to 125 ohms by a  $\frac{1}{4}$ -wave transformer contained inside the loop support. The proximity of the ends of the radiating elements to the screen has been adjusted to produce a current maximum at the middle of each element. The plug connection at the input of the  $\frac{1}{4}$ -wave transformer introduces a disturbance between 1.15/1 and 1.3/1 on the transmission line to the antenna. This plug is the standard AN design used in the localizer. These standing-wave ratios were not considered sufficient to require the development of connectors which would more closely match the flexible transmission line selected.

Extensive tests under all kinds of precipitation including water, snow, wet snow, and ice showed that only wet snow appreciably affected the operation of the antenna system. A plastic cover, which keeps snow a safe distance from the elements, is supplied for the antenna.

#### 4.4.2 Upper Antenna

A dipole bent into the shape of a "V" produces a radiation pattern shown in Fig. 23. The addition of a parasitic dipole reflector modifies

the pattern to approximate closely that required after the 12-degree rotation with respect to the lower antenna. This reflector also improved radiation and reduced reflections.

The "V" radiator and its associated dipole reflector have considerable radiation perpendicular to the plane in which they are located. To conserve this energy, which is helpful in view of the loss in the long cable required to feed this antenna, a duplicate set of radiators was placed above the first set as shown in Fig. 26. The vertical distance chosen is an electrical  $\frac{1}{2}$  wavelength for the transmission line used to feed the upper half of the antenna.

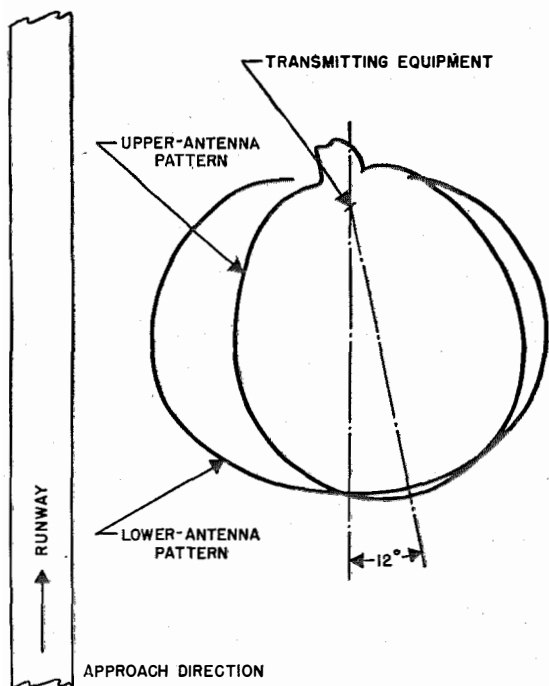

Fig. 24—Horizontal radiation patterns of upper and lower antennas measured at any glide-path angle.

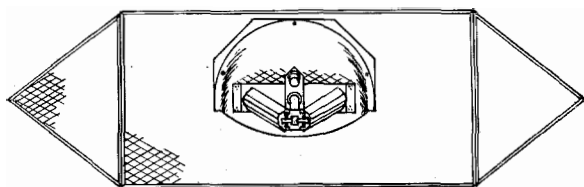

Fig. 25—Screen and lower antenna of glide-path equipment.

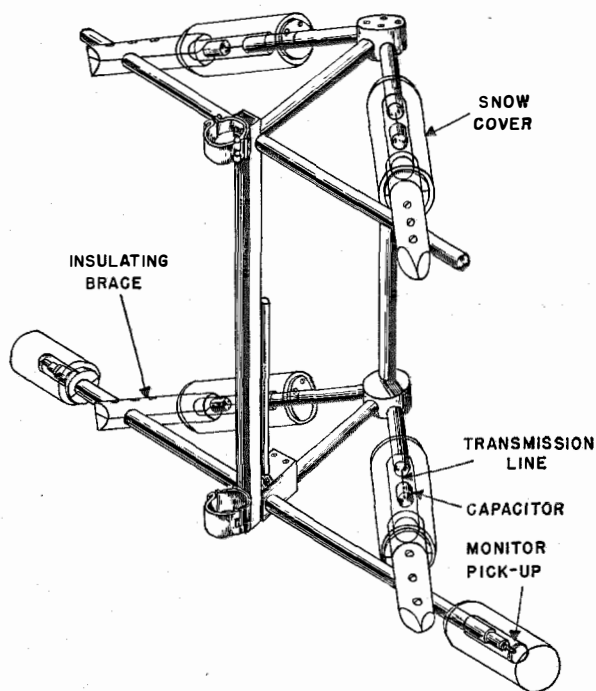

Fig. 26—Upper antenna of the glide-path equipment.

For mechanical rigidity and for convenience in electrically matching the antenna to the flexible transmission line, a capacitively end-fed type of radiator was selected. The capacitive feed system has the equivalent circuit shown in Fig. 27. At each set of radiators, a balanced transmission line divides into two coaxial transmission lines which have capacitive terminations at their ends. The capacitive coupling to the radiating elements terminates each transmission line in a circuit consisting of a series capacitor, resistor, and inductor. The radiators are shortened sufficiently so that at their ends they present an inductive reactance. Since they radiate they have radiation resistance at their ends of a value  $R$ . The capacitance  $C$  results mainly from the capacitor connected to the end of the transmission line. The capacitive reactance of this capacitor is made nearly sufficient to balance the inductive reactance presented at the end of the radiator. As a result, the transmission line is terminated by a resistance equal to  $R$ .

The shunting capacitance  $C_s$  represents the capacitance between the capacitor and the inside

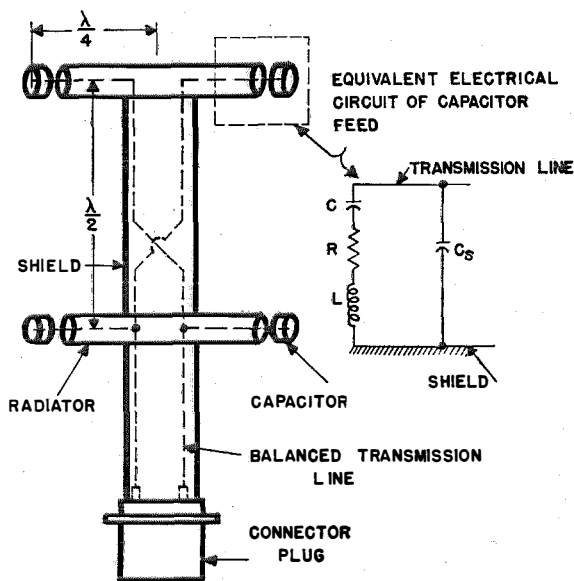

Fig. 27—Schematic diagram of upper antenna.

of the shield. To prevent  $C_s$  from seriously affecting the external circuit, the transmission line emerging from the center of the radiator is led into a small cylindrical capacitor and connects to a cap on the far end of the cylinder rather than at the near end. Such an arrangement allows the capacitor to have its greatest capacitance to the outside of the radiator rather than to the inside of the radiator in a shunting manner. With dimensions as shown in Fig. 26, the value of resistance presented by the capacitors to the transmission lines is about 500 ohms at each end of the balanced "V." By means of the coaxial transmission lines, this resistance is transformed to approximately 250 ohms at the apex of the "V." The two "V's" connected in parallel by a  $\frac{1}{2}$ -wave transmission line, shown schematically in Fig. 27, have an input impedance of 125 ohms which matches the 125-ohm surge impedance of the flexible transmission line.

The field around the capacitors at the ends of the "V's" is most intense within about 1 inch of the conductors. If wet snow changes appreciably the dielectric constant in this region, the impedance presented by the antenna to the transmission line will vary considerably. To prevent such undesirable effects, insulating covers, about three times the diameter of the radiators,

have been provided for these critical regions. With these additions, an accumulation of wet snow or other precipitation causes no appreciable disturbance.

#### 4.5 PHASE RELATIONS OF SIGNALS

Because of the wide separation in electrical degrees between the upper and lower antennas, final phase relations between the two radiated signals occur approximately 1 mile from the antennas for glide-path angles of about  $2\frac{1}{2}$  degrees. This distance varies inversely with glide-path angle. Phase conditions and a mathematical analysis of the effects of phase shifts along the glide path are given in Appendixes IV and V, and show that:

- Maximum range can be obtained when, at all points beyond 1 mile from the equipment, the phase difference between the carriers is not more than approximately  $\pm 30$  degrees.
- Clearances at the first and third low-clearance points above the path can be considerably increased over the values in Fig. 18 if the phase conditions noted above are obtained.

According to the analysis in Appendix V, even greater clearance can be obtained by somewhat different phasing than the optimum, but this is at some sacrifice in range. Therefore, the equipment has been phased within the 30-degree limits mentioned. Fig. 28 shows that carriers on a  $2\frac{1}{2}$ -degree glide path have a 57-degree phase shift between a point several miles from the

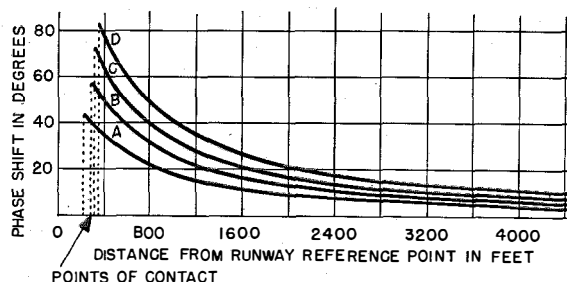

Fig. 28—Phase shift along glide path as a function of distance from point of contact. Glide-path angles: A=3 degrees, B=2.5 degrees, C=2.25 degrees, and D=2 degrees.

equipment and the point of contact. In view of this fact, it was decided to advance the phase of the carrier in the upper antenna by about 27 degrees to keep the phase shift on a  $2\frac{1}{2}$ -degree glide path within reasonable limits over the full length of the path. Such a phasing condition results in a 27-degree advance of the upper-antenna carrier with respect to the lower-antenna carrier several miles from the equipment and a 30-degree retard at the point of contact. If this were not done, the harmonic content developed on the latter part of the glide path shortly before the point of contact might change the indicated shape of the glide path, depending on the characteristics of the filter system in the receiver.

#### 4.6 PATH HEIGHT AND SHAPE MEASUREMENTS

##### 4.6.1 System Components

The two antennas are supported on a 3-inch demountable aluminum mast. This mast is mounted on and guyed from a small trailer which also carries the 335-megacycle transmitter, the associated power supply, a mechanical modulator, and a gasoline-engine-driven 60-cycle generator. The whole system can be disassembled and transported on the trailer. The equipment may be removed from the trailer and installed in a small house.

The antennas are aligned with respect to each other by rotation of the mast. The upper antenna is clamped to the mast and is positioned by a dowel in one of the clamps. The lower antenna, also clamped to the mast, can be loosened to rotate the mast without turning the screen. The screen is firmly attached to the trailer.

##### 4.6.2 Shape of Path, Ground Measurements

If the parameter  $r$  shown in Fig. 20 is held constant, the height of a receiving antenna is proportional to the cosine of  $\theta$  when a straight-line glide path is produced. Therefore, the complete glide-path equipment can be placed on a turntable as shown in Fig. 29 and rotated to vary the angle  $\theta$  while observing the height of the glide path at some fixed distance.

A receiver was connected by a flexible transmission line to an antenna of adjustable height

at an observation point 400 feet from the glide-path turntable. The turntable was rotated in 5- and 10-degree steps through an angle of 120 degrees and back again to obtain the average of

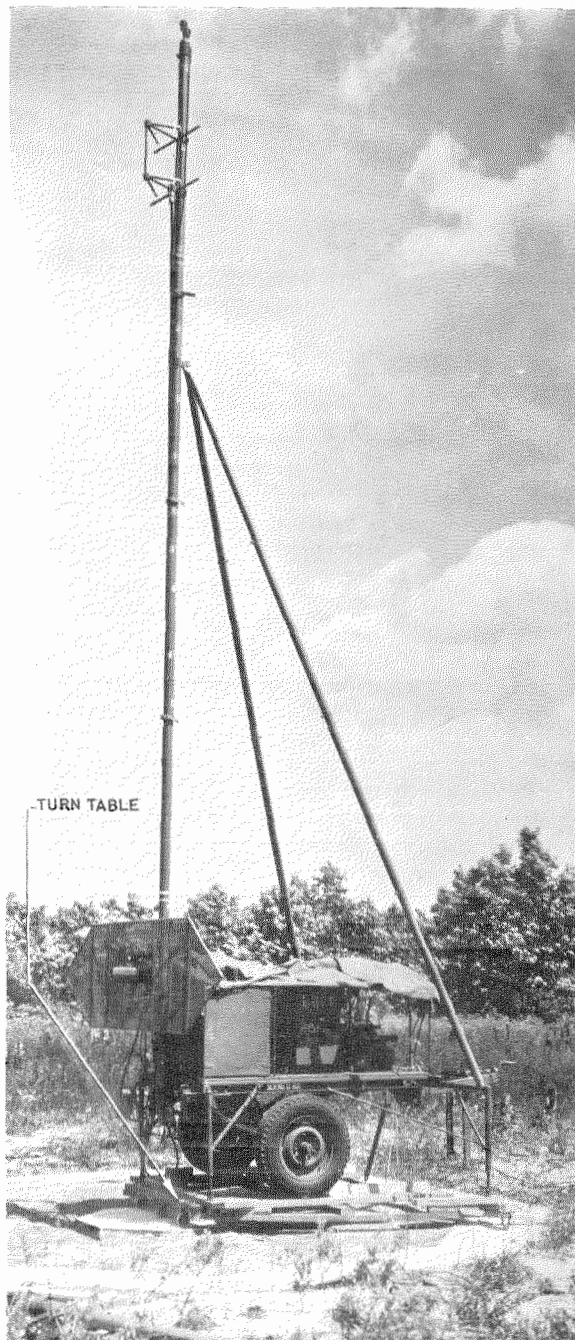

Fig. 29—Glide-path equipment mounted on turntable to check height of glide path at a fixed distance as a function of the angle  $\theta$ .

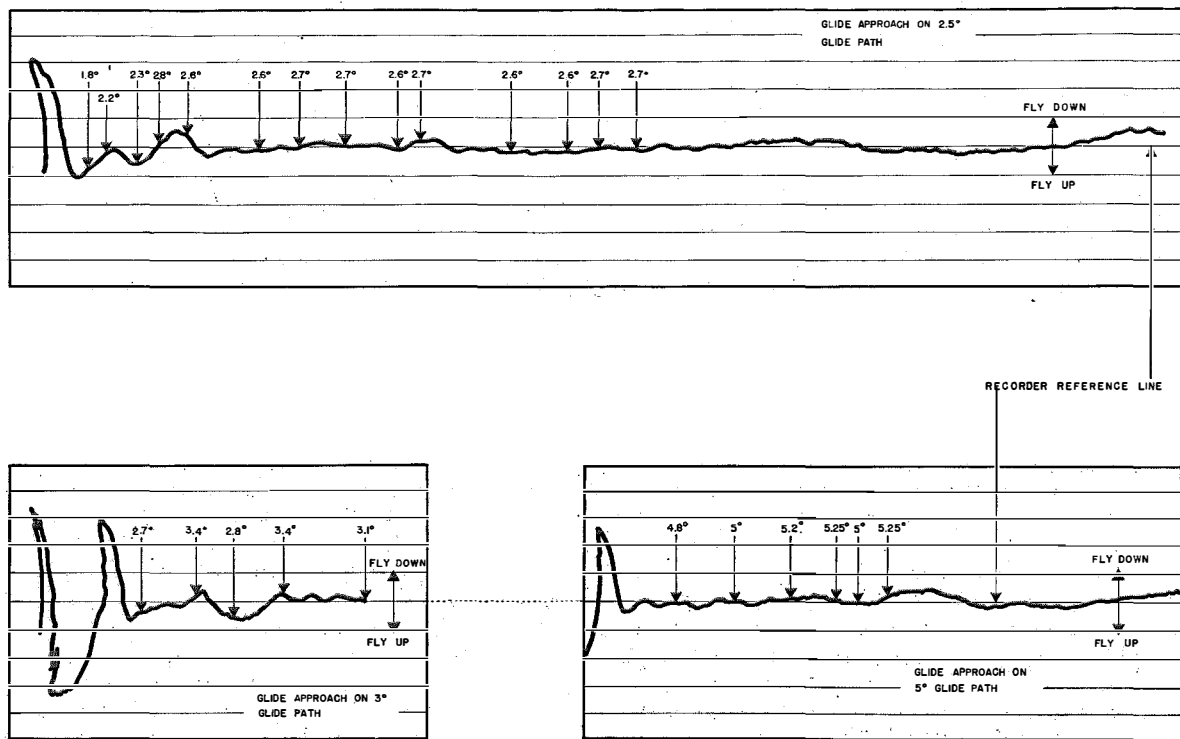

Fig. 30—Records of flights to check glide-path angles.

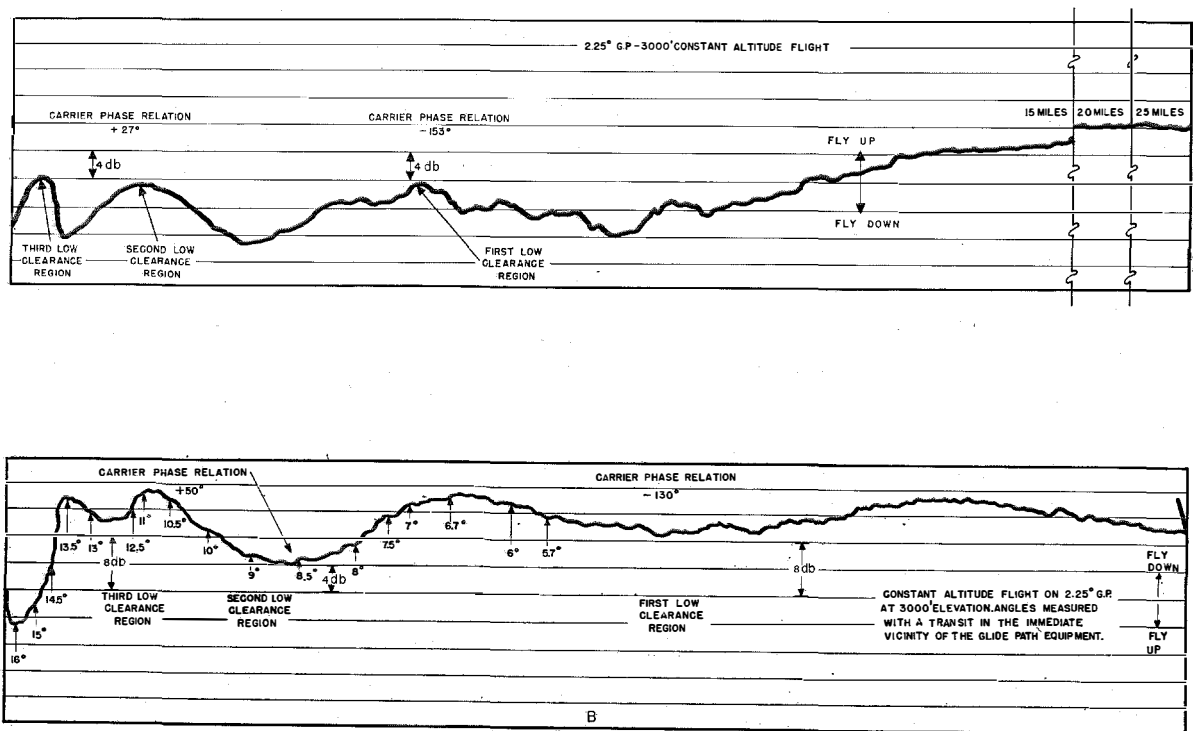

Fig. 31—Records on 2.25-degree glide path taken at a constant airplane altitude of 3000 feet showing 3 low-clearance regions.

two readings at each point. The heights at zero degrees were multiplied by the cosine of the angles through which the equipment was rotated to determine what the exact height of the glide path should have been at those angles. These values are given in Table I.

Between approximately 0 and 60 degrees the path decreased in height more rapidly than it should have. This is in accord with the nature of the radiation patterns of the upper and lower antennas as discussed previously and as shown in Fig. 21. A glide path of this shape was chosen to provide a positive "down" indication over a sufficient distance beyond the point of contact on the runway. For all glide-path angles up to and including 3 degrees, this distance had to be not less than 350 feet.

4.6.3 Shape of Path, Flight Measurements

Flight checks were conducted to determine the nature of the glide path as observed in an aircraft and to substantiate measurements made from the ground. Fig. 30 gives records of glide approach flights in which the observer in the airplane notified those on the ground when to note the angles subtended between the airplane and the earth. In the majority of cases, when the airplane was above or below the path, the recordings (on which the ground observations were also marked) indicated that such was the case. In other words, all deviations of appreciable magnitude on the recordings corresponded to points at which the airplane apparently was not on the path.

4.6.4 Clearance Measurements

To determine clearances between the glide-path angle and 6 times that angle, constant-altitude flights were made over the equipment. During these flights, the vertical angles subtended by the airplane were also noted by the ground observers at various intervals designated by the observer in the aircraft.

On the recording, Fig. 31A, the first and second low-clearance regions are of equally great clearance. From the vertical-radiation characteristic shown in Fig. 18, the recorded data appear to be in conflict with the calculated amplitude ratios.

TABLE I  
PATH-SHAPE MEASUREMENTS ON 2.25-DEGREE  
GLIDE PATH

Horizontal Angle $\theta$ in Degrees*	Theoretical Height for Straight-Line Glide Path in Feet	Average Height of Antenna in Feet†	
		Right Side	Left Side
-10	—	15.8	15.8
0	15.8	15.8	15.8
5	15.7	15.4	15.3
10	15.6	15.0	15.0
15	15.3	14.7	14.7
20	14.8	14.4	13.8
25	14.3	13.8	12.8
30	13.7	13.1	12.3
40	12.1	11.9	10.4
50	10.3	9.2	9.1
60	7.9	7.8	6.9
70	5.4	6.9	5.5
80	2.7	6.9	5.5
90	—	7.0	4.2
100	—	9.3	4.2
110	—	12.8	7.2
120	—	16.8	11.2

\* Point of contact is at 52.7 degrees.

† For receiving antenna 400 feet from glide-path antennas with equipment oriented, as viewed from the airplane, for the side of the runway indicated.

However, after consideration of the effects of various carrier shifts with respect to side-band phases, the reason for the apparent discrepancy is for the most part explainable (see Appendix V). It must be remembered that the phase of the carrier in the second vertical lobe produced by the upper-antenna signal, Fig. 18, is 180 degrees out of phase with the radio-frequency energy in the first and third lobes but is in phase with the fourth lobe. Before the flight measurements were taken for Fig. 31A, the signal of the first lobe of the upper antenna was adjusted to be about 27 degrees advanced in phase with respect to the signal from the lower antenna. As a result there was a very appreciable carrier cancellation and carrier phase shift in the region of the second lobe of the upper antenna. When such out-of-phase conditions exist, the signal of higher level appears to swamp the signal of lower level resulting in an increase of ratio between fundamental audio signals (see Appendix V). This explains why the clearances on the recording appeared to be greater than were expected. The lack of agreement in clearances between measured and calculated values probably results from inability to adjust the phases of the two carriers to within



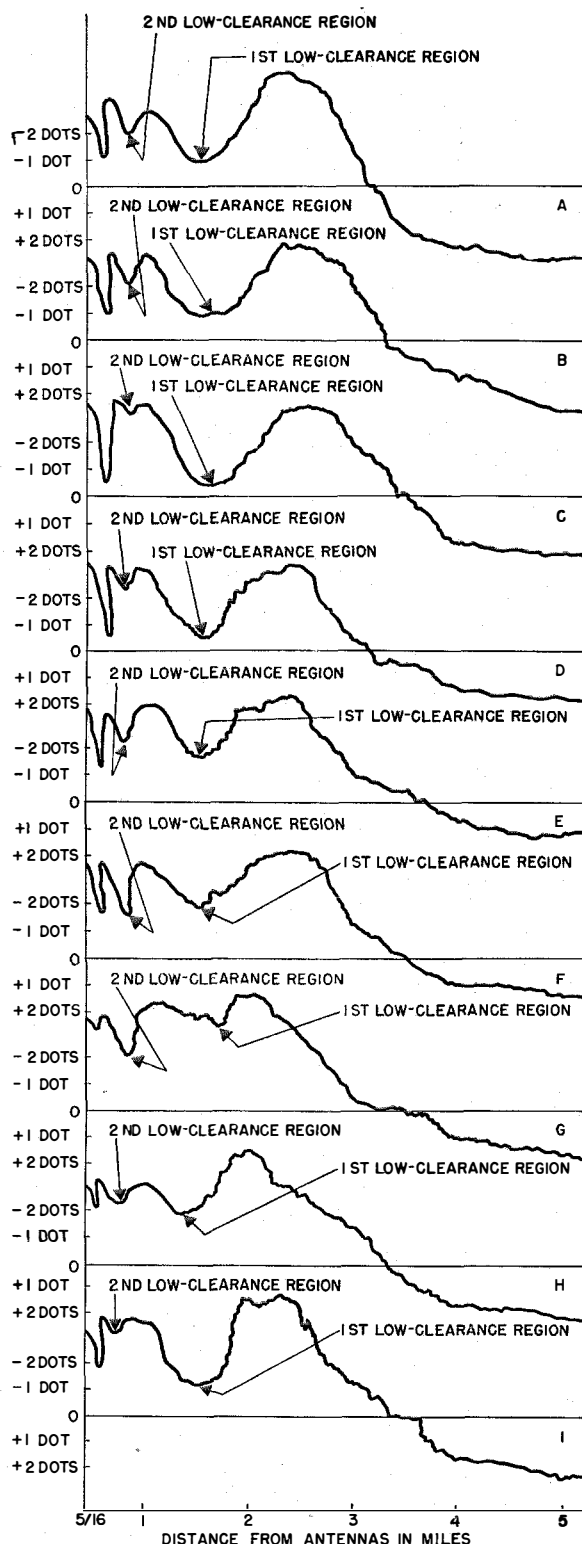

Fig. 32—Glide-path instrument indications on level flight 800 feet above ground for 9 (A-I) carrier phase-shift variations between 0 and 360 degrees. Minus and plus values are equivalent to "fly-down" and "fly-up" instrument indications, respectively.

closer than  $\pm 10$  degrees. Further, phase modulation in the modulator prevents any phase relation between carriers from remaining fixed. Each carrier is modulated to some extent in phase as well as amplitude.

The phase relationships which existed between the carriers during the recording of Fig. 31B were known to be further out of phase at a far-distant point on the glide path than the phase relations which existed for the recording shown in Fig. 31A. In the case of Fig. 31B, the phase shift between carriers far out on the glide path was approximately 50 degrees. Under these conditions, the phase relations in the region of the first low clearance were in the order of 130 degrees. From Fig. 31B it can be seen that the ratio of signals was considerably greater than that shown in Fig. 18.

It is to be noted from Fig. 31B that the vertical angles subtended by the aircraft as observed by the transit on the ground identified the low-clearance points with those shown on the calculated curves in Fig. 18. This left no doubt as to the identity of the clearance regions marked on the various recordings.

Fig. 32 shows a group of recordings in which the phase shifts between carriers were carried over a wide range of angles from 0 to 360 degrees. In most cases, the accuracy of the phase relationships for each particular case was not well known and, therefore, the phase relationships are not included on the recordings. However, these recordings show rather clearly how the clearances in the first, second, and third low-clearance regions vary with carrier phase relations. In a general way, the agreement between the results shown in Fig. 32 and various calculated results given in Appendix V is demonstrated. For instance, in the case of curve C, Fig. 32, the second low-clearance region indicates that the carriers at this point were probably 130 to 150 degrees out of phase. It was definitely known that the phase relationships which existed for the recording of curve G were exactly opposite to that of the phase relationships of curve C. A comparison between these two curves, with the phase relationships known to exist between them, further substantiates the theoretical facts demonstrated in Appendix V. In the light of this discussion concerning clearances, it may be concluded that the adjustment

of the phase relation between carriers is not critical, but should not exceed  $\pm 30$  degrees to assure maximum range and to prevent the occurrence of low clearances in the first and third low-clearance regions above the path.

#### 4.7 MECHANICAL MODULATOR

Fig. 33 shows a schematic diagram of the mechanical modulator, transmission lines, and antennas. The modulator is similar to that used in the localizer except that nearly all components are one-third the size (see Fig. 34). Since the side bands and carrier need not be separated from each other, only one radio-frequency bridge is included, the cross-modulation bridge.

The energy fed to the upper antenna is considerably less than that fed to the lower antenna. The full output of energy to the upper antenna is limited in the 150-cycle modulation trough. The modulating section is provided with smaller stator plates so that the rotor cannot completely detune the section thus preventing the full pass of energy in the associated transmission line.

A vernier adjustment is provided on the current amplitude sent to the upper antenna by means of a mismatching building-out section attached to the upper-antenna transmission line in the modulator. This building-out section is labeled "Amplitude Control"; plus and minus incremental path-angle adjustments can be obtained by moving the short on this building-out section.

#### 4.8 OUTPUT METER

A thermocouple is suitably connected across the line in the modulator which carries current to the upper antenna. The direct-current meter actuated by the thermocouple is mounted in the monitor section on the front panel of the transmitter (see Fig. 35). The meter gives relative indications of upper-antenna current and transmitter output.

#### 4.9 MONITORING

The lower parasitic reflector of the upper antenna is equipped with a capacitively excited pick-up circuit which feeds monitor indications into a mixing network in the monitor compartment of the transmitter cabinet. There

is also a little loop in the immediate vicinity of the lower antenna which feeds a small amount of lower-antenna signal into the mixing and isolating network previously mentioned.

The output of this network, after passing through a diode detector, is amplified and then fed into a filter and rectifier system. The output operates a cross-pointer indicator on the front panel of the modulator and also sensitive relays in the power-supply cabinet. Any change of signal in either antenna is readily detected and indicated on the cross-pointer instrument. If the change becomes sufficient to raise or lower the glide path by 10 percent, the sensitive relays remove the plate voltage from the output stage and also sound a warning horn.

This type of monitor was developed for the glide-path equipment since it simplifies the set-up problem associated with portable apparatus. It also eliminates an external monitor which would be an additional obstruction. However, since its accuracy depends on the adjustment of its two pick-up devices, it requires the use of a calibrating unit such as a standard glide-path receiver and antenna system or a portable path detector as described hereinafter.

Since this monitor is a secondary rather than a primary type, permanent installations which are required to operate unattended a much greater percentage of the time might be more accurately monitored by an external monitor.

#### 4.10 TRANSMITTER

The transmitter is of the conventional type. The frequency of a crystal oscillator is multiplied 18 times in an exciter unit. The output of the latter is fed into a final tripler stage to complete 54 multiplications of the crystal frequency. The output of the tripler stage is used to drive a balanced amplifier which can supply thirty watts of unmodulated carrier.

#### 4.11 TEST EQUIPMENT

As in the case of the localizer, several types of test equipment were developed. Again the path detector, counterpart to the portable course detector, is the most important unit (see Fig. 36). Obviously, such a unit cannot be used by hand at more than a few hundred feet from the

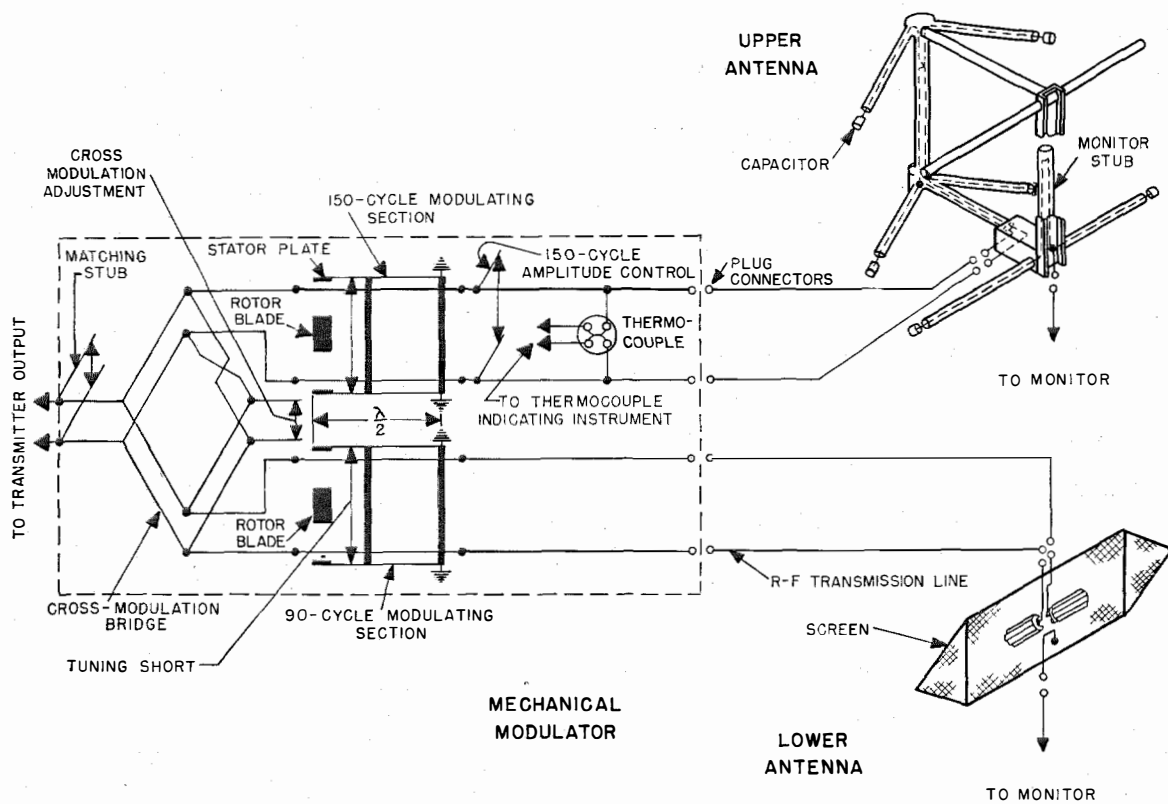

Fig. 33—Circuit arrangement of the mechanical modulator, transmission lines, and radiators for the glide-path system.

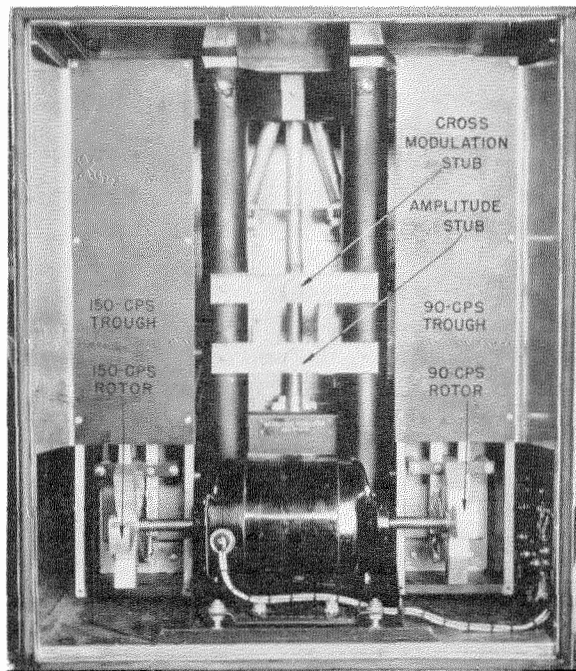

Fig. 34—Mechanical modulator housed in transmitter cabinet.

equipment; consequently, its sensitivity does not have to be great. It consists of a grid-leak detector which feeds an audio amplifier and filter-rectifier system. A switch and meter are provided for measuring path indications, clearances, filter voltage, etc.

#### 4.12 AIRCRAFT RECEIVER

The aircraft receiver is a typical super-heterodyne with two unique features: (a) The receiver operates directly from the standard 28-volt direct-current aircraft supply with no higher voltages in any circuit. (b) Its input circuits consist of small cavity resonators. The audio output is fed to the standard filter-rectifier circuit which actuates the cross pointer.

One further interesting feature of the receiver is an automatic "Up" indication which it produces when not receiving a signal. The plate circuit of one tube in the receiver is connected to the cross pointer. Automatic-volume-control current biases the tube to cut off when a signal

is being received so that no effect is had on the cross pointer. However, when no signal is received and no bias is applied to the alarm tube, its plate current produces the desired "Up" deflection.

### 5 Marker Beacons

The safe landing of an airplane requires that three conditions be fulfilled: (a) alignment of the airplane with the runway, (b) descent to a specified point on the runway at an angle that will avoid sharp changes of attitude of the airplane at the moment of contact with the ground, and (c) the maintenance of speed sufficiently high to permit complete control of the flying qualities of the airplane up to the moment of contact with the ground and a rapid reduction of speed to zero within the remaining distance to the end of the runway.

Information on the alignment of the airplane is provided by the localizer, the descent is made

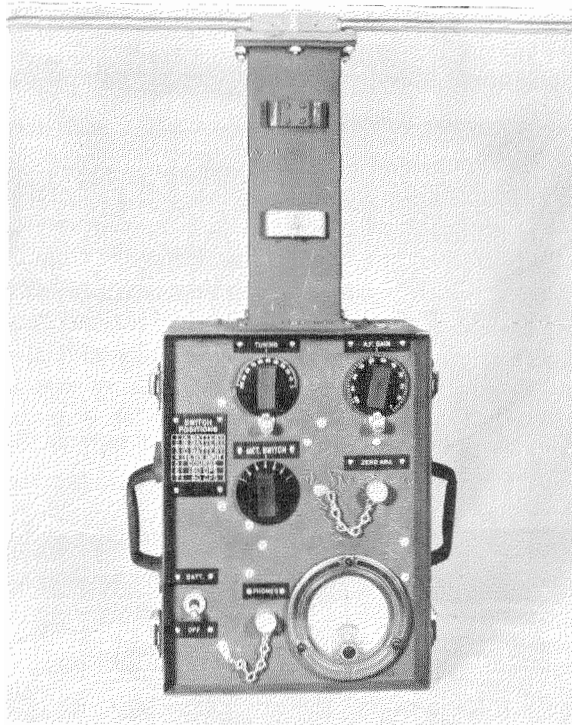

Fig. 36—Front view of portable glide-path detector.

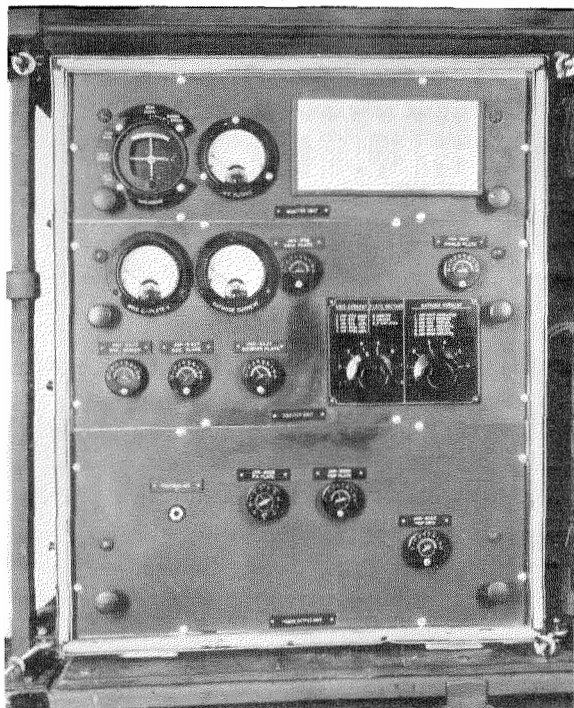

Fig. 35—Front view of transmitter with door removed.

under the guidance of the glide-path system, and the distance of the airplane from the landing field is indicated by marker beacons. Three 75-megacycle marker-beacon transmitters project narrow bands of radiation across the localizer course. The outer marker radiation, modulated at 400 cycles by dashes, intersects the localizer course 4.5 miles from the airfield. The middle marker is modulated by 1,300-cycle dots and is 1 mile from the field. The boundary marker is at the approach end of the runway and transmits a constant 3,000-cycle signal.

A separate marker-beacon receiver is carried in the airplane. The signals produce audible tones in headphones and simultaneously operate a light to notify the pilot when the airplane is directly over the marker beacon. The pilot is thus enabled to judge the distance of the airplane from the field and, in conjunction with the localizer and glide-path signals, make a safe instrument landing on a runway which may not even be visible to him.

## APPENDIX I

**6 General Theory of Localizer Arrays**

The simplest localizer array which will produce 2 courses is that shown in Fig. 37A. The side-band energy fed to antenna *B* is half of the side-band energy contained in a carrier modulated 100 percent by 90- and 150-cycle signals. The side-band separation has been accomplished in an electrical circuit contained in the mechanical modulator. The remaining carrier and side bands are fed to antenna *A* which is spaced *D* electrical degrees from antenna *B*. It is to be noted that the carrier, stripped of half of its side bands, becomes approximately 70 percent modulated and that the side-band energy in the two radiators reduces to approximately 70 percent of the amplitude before the separation occurred.

Fig. 37B shows vectorially the phase relations between the side-band energies radiated from *A* and *B* to produce the sharpest course by the given system. It is desired that the 90-cycle side-band energy shall predominate to the right of the course and that the 150-cycle energy shall predominate to the left of the course. This requires that the side-band energy phases be related as shown in this figure. The resultant side-band energies produced on course are equal. The 150-cycle energy is advanced 45 degrees in phase with respect to the corresponding side-band energy in *A* and the 90-cycle side-band energy is retarded in phase by 45 degrees. It will be shown in a later appendix that such phase shifts do not produce undesirable harmonic or cross-modulation products provided they are not greater than approximately 45 degrees. This is especially true as the modulation is decreased from 100 percent.

In Fig. 37C, radiators *A* and *B* are shown as point sources. The point *P* is greatly distant from either *A* or *B* so that radiations to that point are essentially parallel as indicated by the geometrical construction of the figure. It is clear that all radiations from *B* will be advanced on their arrival at *P* with respect to *A* by an amount ( $D \sin \theta$ ). Fig. 37D shows the vector relations of the side-band energies produced at *P*. The 90-cycle side-band energy considerably predominates as was desired.

Equations (7) and (9) represent the side-band energies transmitted to *P* from *A* and *B*. Equations (8) and (10) are trigonometric transformations of equations (7) and (9) in which the space-phase and time-phase relationships have been separated. The space-phase relationships (cosine functions) represent the space patterns produced by the system. From these equations it can be shown by differentiation that the arbitrary phases represented by  $\phi$  of the side-band energies in *B* with respect to *A* should be 90 degrees for optimum course sharpness. Substituting 90 degrees for  $\phi$  in these cosine expressions and a value of 163 degrees for *D*, the side-band patterns of Fig. 37E can be obtained (163 degrees was chosen as this is the separation between the carrier radiator and the immediate side-band radiators in the Army portable localizer).

Equation (11) represents the carrier radiated from *A*. This energy added to the side-band energy is shown in equation (12) which represents the signal radiated from this system. Parasitic action occurs between *A* and *B*. For clarity it is discussed later for a special case.

It is advantageous to provide a means of shifting the course without mechanically rearranging the antenna elements. This can be done by changing the length of the line carrying the side-band energy to radiator *B*. Assume that this line has been shortened by an amount  $\psi$  in which case the energies transmitted to *B* will be advanced in phase by an angle  $\psi$ . From Fig. 37F it is clear that a physical displacement from the perpendicular to the line joining *A* and *B* sufficient to produce a phase delay of ( $D \sin \theta'$ ) will be required to re-establish equal magnitudes of the respective side-band energies. The course will then lie along a line making an angle of  $\theta'$  with respect to the previous course line.

There has been nothing in the discussion so far that required that antenna *B* be placed on one side or the other of antenna *A* or that another antenna *B'* (shown dotted) could not be placed the same or a different distance on the opposite side of antenna *A*. If such an antenna is placed an equal distance on the opposite side of *A*, a special case results which forms the basis of the most widely used system. From the previous derivation it is clear that the phase relations of side-band radiators such as *B'* placed

on the opposite side of  $A$  from  $B$  have to be phased exactly opposite to the phases of the energies in  $B$ .

When antennas  $B$  and  $B'$  are equally spaced on either side of  $A$ , no parasitic action results in  $A$  as a result of excitation from  $B$  and  $B'$ . However, radiation from  $A$  excites both  $B$  and  $B'$ . Fig. 10 shows that antennas  $B$  and  $B'$  are connected by a tie line. The length of this line controls the phase of the parasitic action induced by  $A$  in  $B$  and  $B'$ . It is most desirable that the parasitic action be phased to radiate the induced energy from  $B$  and  $B'$  in phase with the existing energy from  $A$ . Equation (13) then shows the total side-band energy of one side band radiated from such a system. The magnitude of the side-band energy fed to  $B$  and  $B'$  is  $\frac{1}{2}$  the energy originally fed to  $B$ . This results in a reduction of voltage from the 0.7 value to 0.5 as shown.

By measurement, the amplitudes of the currents in  $B$  and  $B'$  are usually about  $\frac{1}{4}$  the current in the exciting antenna  $A$ . Assuming that the radiation resistance of  $A$  is not appreciably changed by this parasitic action, the 1 unit of energy divided among the 3 radiators results in the current distribution shown in the second part of equation (13). Equation (14) is a trigonometric transformation of equation (13) from which the final side-band pattern of the 90-cycle energy can be obtained. Equations (15) and (16) are the corresponding equations for the 150-cycle energy and carrier. Equation (17) is the complete equation for the system, including the carrier energy.

From the foregoing, it is clear that almost any arrangement of antennas can be formed into a localizer. The system selected for the Army portable localizer, in which 3 main radiators are symmetrically arranged with 2 auxiliary radiators placed off to one side, will produce the sharpest course for the minimum over-all distance between antennas at opposite ends of the array. Equation (18) is complete for the 5-loop localizer in which the energy distribution among the side-band radiators results in no false courses. In addition, no low-clearance points of less than 4 decibels are produced over the range of frequencies specified.

Placing the 2 auxiliary radiators side by side with a separation of 180 degrees as shown considerably assists in preventing false courses at large angles from the course. The 2 radiators so placed direct their maximum energy along the course where it will provide maximum sharpness; no energy is radiated at right angles to decrease clearances or cause false courses.

## APPENDIX II

### 7 *Effect of Impure Polarization of Localizer Signals*

Fig. 38A shows an antenna with a transmission line coupled to the input circuit of a receiver. Assume that a modulated signal having a component of stress in a horizontal direction shown by the vectors 1, above and parallel to the antenna, also has a stress at right angles to these vectors shown by the vector 2 down the transmission line. Assume that there is a capacitive coupling as well as an inductive coupling at the input circuit of the receiver. Fig. 38B shows the assumed phase relation between the currents induced in the input circuit in one case. It is seen that the resultant signal  $R$  is quite large.

If the antenna system is rotated through 180 degrees (reversal of direction of flight), the vertical component remains in the same phase while the horizontal signal induces current exactly opposite in phase. These phase relations are shown in Fig. 38C. The resultant signal is seen to be very much smaller than in the former case. If the resultant signal in the first case produced an on-course indication, rotation of the receiving system will no longer give this result. The side-band energies would be equalized at a new location.

This influence of the direction of flight on the location of the course has been noted in practice and is referred to as "push." The polarization of the radiation from the localizer system should be as pure as possible to avoid phenomenon of this nature.

## APPENDIX III

### 8 *Mechanical Modulator*

A schematic radio-frequency wiring diagram of the mechanical modulator and radiation system is shown in Fig. 10. The transmitter feeds

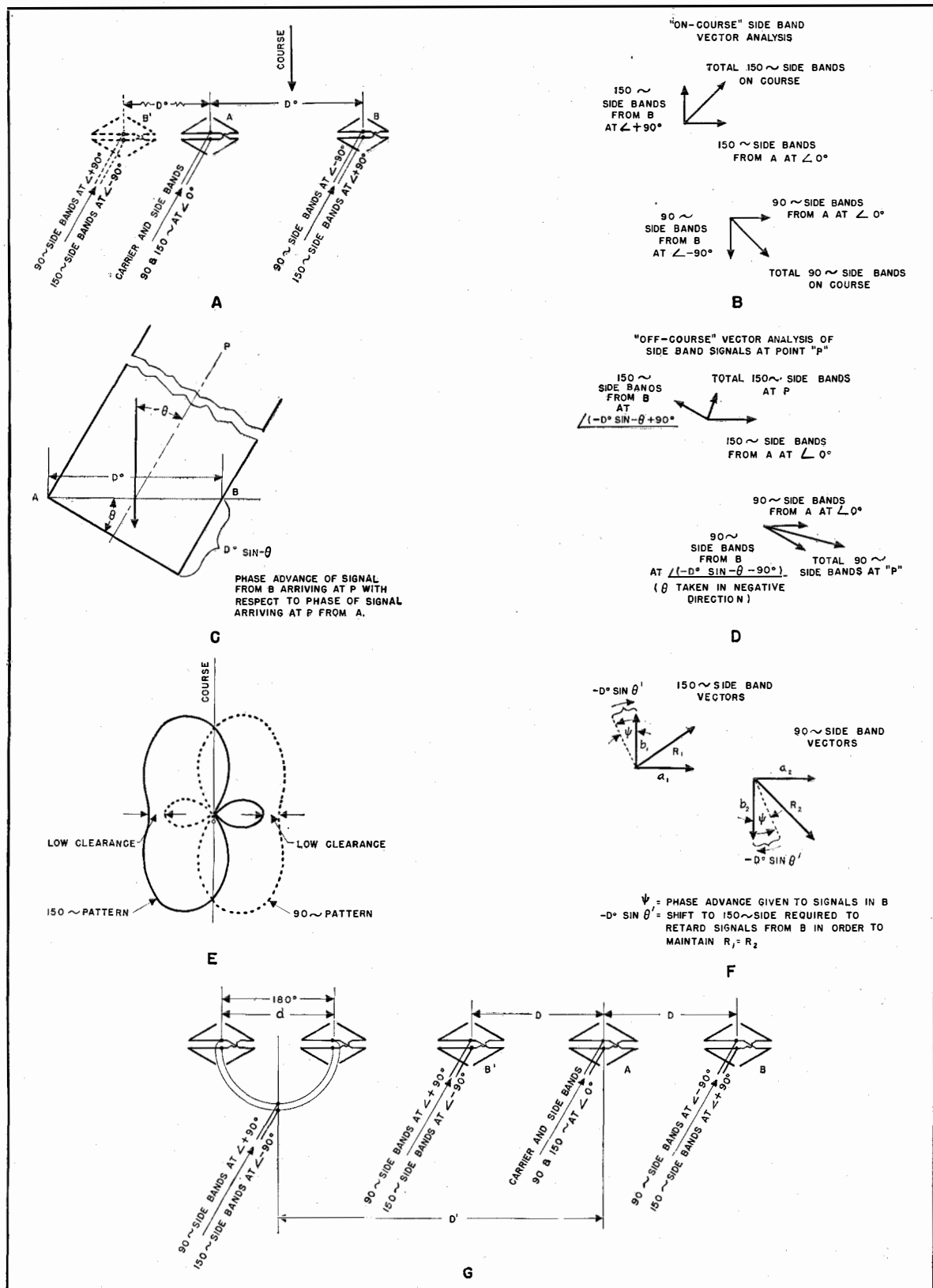

Fig. 37—Vector analyses of side bands for "on-course" and "off-course" conditions.

EQUATIONS FOR FIGURE 37

DERIVATION OF EQUATION FOR 2-LOOP LOCALIZER SIDE-BAND PATTERNS

$$F_{P_{150\sim}} = [0.7 \sin \omega_0 t + 0.7 \sin (\omega_0 t + \phi - D \sin \theta)] m \cos \omega_{s_1} t \tag{7}$$

$$= \left[ 1.4 \sin \left( \omega_0 t + \frac{\phi}{2} - \frac{D}{2} \sin \theta \right) \cos \left( -\frac{\phi}{2} + \frac{D}{2} \sin \theta \right) \right] m \cos \omega_{s_1} t \tag{8}$$

} 150~ side band

$$F_{P_{90\sim}} = [0.7 \sin \omega_0 t + 0.7 \sin (\omega_0 t - \phi - D \sin \theta)] m \cos \omega_{s_2} t \tag{9}$$

$$= \left[ 1.4 \sin \left( \omega_0 t - \frac{\phi}{2} - \frac{D}{2} \sin \theta \right) \cos \left( \frac{\phi}{2} + \frac{D}{2} \sin \theta \right) \right] m \cos \omega_{s_2} t \tag{10}$$

} 90~ side band

$$F_C = 2 \sin \omega_0 t \quad (\text{Carrier from } A \text{ for both Side Bands}) \tag{11}$$

(Let  $\phi = 90^\circ$   $D = 163^\circ$ )

$$F_T = 2 \sin \omega_0 t + [1.4 \sin (\omega_0 t + 45^\circ - 81.5^\circ \sin \theta) \cos (+45^\circ - 81.5^\circ \sin \theta)] m \cos \omega_{s_1} t$$

$$+ [1.4 \sin (\omega_0 t - 45^\circ - 81.5^\circ \sin \theta) \cos (-45^\circ + 81.5^\circ \sin \theta)] m \cos \omega_{s_2} t. \tag{12}$$

SPECIAL CASE—SYMMETRICAL ARRAY, 3-LOOP LOCALIZER

$$F_{P_{90\sim}} = \left\{ \underbrace{0.5 \sin (\omega_0 t - D \sin \theta - \phi)}_{\text{From } B} + \underbrace{0.5 \sin (\omega_0 t + D \sin \theta + \phi)}_{\text{From } B'} \right.$$

$$\left. + \underbrace{0.94 \sin \omega_0 t}_{\text{From } A} + \underbrace{0.23 \sin (\omega_0 t - D \sin \theta)}_{\text{From } B} + \underbrace{0.23 \sin (\omega_0 t + D \sin \theta)}_{\text{From } B'} \right\} m \cos \omega_{s_2} t \tag{13}$$

Parasitic Action from A

$$= \{ \sin \omega_0 t [0.94 + 0.46 \cos (D \sin \theta) - \sin (D \sin \theta)] \} m \cos \omega_{s_2} t \tag{14}$$

$$F_{P_{150\sim}} = \{ \sin \omega_0 t [0.94 + 0.46 \cos (D \sin \theta) + \sin (D \sin \theta)] \} m \cos \omega_{s_1} t \tag{15}$$

$$F_C = 2 \sin \omega_0 t [0.94 + 0.46 \cos (D \sin \theta)] \tag{16}$$

$$F_T = \sin \omega_0 t \left\{ \begin{array}{l} 2[0.94 + 0.46 \cos (D \sin \theta)] \\ + m \cos \omega_{s_2} t [0.94 + 0.46 \cos (D \sin \theta) - \sin (D \sin \theta)] \\ + m \cos \omega_{s_1} t [0.94 + 0.46 \cos (D \sin \theta) + \sin (D \sin \theta)] \end{array} \right\} \tag{17}$$

5-LOOP LOCALIZER EQUATION

$$F_{P_T} = \sin \omega_0 t \left\{ 1.88 + 0.92 \cos (D \sin \theta) \right.$$

$$+ m \cos \omega_{s_1} t \sqrt{[0.94 + 0.46 \cos (D \sin \theta) + 0.86 \sin (D \sin \theta) + 0.44 \cos (d \sin \theta) \sin (D' \sin \theta)]^2 + [0.44 \cos (d \sin \theta) \cos (D' \sin \theta)]^2} \tag{18}$$

$$\left. + m_2 \cos \omega_{s_2} t \sqrt{[0.94 + 0.46 \cos (D \sin \theta) - 0.86 \sin (D \sin \theta) - 0.44 \cos (d \sin \theta) \sin (D' \sin \theta)]^2 + [0.44 \cos (d \sin \theta) \cos (D \sin \theta)]^2} \right\}$$

unmodulated energy into a cross-modulation bridge which divides the energy equally and feeds it to two mechanical modulating circuits. The antenna bridge then combines the carrier energies with  $\frac{1}{2}$  of the side-band energies and feeds them to the carrier loop. The other  $\frac{1}{2}$  of the side-band energies is divided in 2 unequal parts. The larger part goes to the side-band

radiators in the main group and the smaller goes to the auxiliary radiating group after passing through a phasing unit.

The cross-modulation bridge is a circuit which will not pass energy from one to the other output arm. The cross-modulation load is an impedance equal in magnitude and phase angle to that connected to the opposite corner which consists



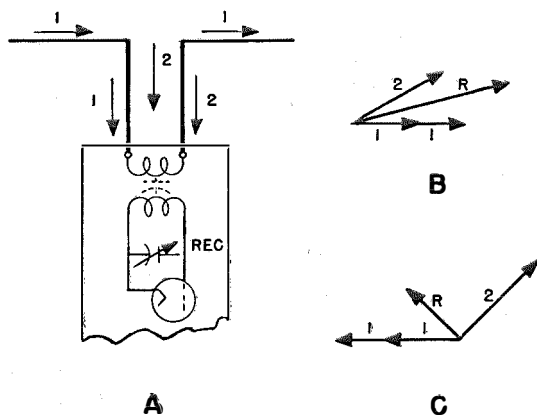

Fig. 38—Transmission line and receiver input circuit and vector diagrams of stress combinations.

of a building-out section and the transmitter input circuit. Any energy directed into either of the bridge arms from the modulating sections cannot therefore develop a voltage at the diagonally opposite output terminal. Any energy reflected from one modulating section towards the bridge cannot feed directly into the other modulating section. This prevents cross modulation.

The modulating circuits consist of inductively coupled, shorted,  $\frac{1}{4}$ -wavelength sections of line supported above the transmission lines from the output terminals of the cross-modulation bridge. Fig. 39 shows schematically how these modulating sections function. A shorted  $\frac{1}{4}$ -wavelength transmission line is inductively coupled to a main transmission line carrying energy to a load as shown in Fig. 39A. The reaction on the main line increases as the  $\frac{1}{4}$ -wavelength line is tuned to resonance by an adjustable short *S*. At resonance, a short circuit is induced in the main transmission line directly beneath the short thus stopping the flow of all energy past this point.

If the ends of the  $\frac{1}{4}$ -wavelength line are fitted with capacitor plates, the circuit can once again be brought to resonance by the adjustable short, Fig. 39B. If now, the blade of a metallic rotor is inserted and then removed from between the capacitor plates, the section will be alternately tuned and detuned. If the stator plates and the rotor blades are properly shaped, the tuning and detuning will occur in a sinusoidal manner.

Modulation is thus accomplished without the use of any electronic devices, moving contacts, or other troublesome mechanisms. The antenna bridge, being similar to the cross-modulation bridge, will not feed energies from one source to another. Energies will flow only to the output terminals providing the impedances at the opposite corners of the bridge are matched. If equal carrier energies are fed to the input corners of this bridge, they will cancel at one output corner and add at the other thus separating the carrier and side bands. The side bands may be fed to the antenna system and, being of different frequencies, will divide equally at the two output terminals.

The small amount of energy fed to the auxiliary antennas is obtained by connecting a shorted  $\frac{1}{4}$ -wavelength transmission line to the side-band output terminal of the antenna bridge. Such a device can be used as a voltage divider and adjustable taps are provided to control the energy supplied to the phasing unit. The latter is used as a course-shifting means.

Fig. 40 shows the principle of operation of the phasing unit. If the electric field around a transmission line exists in a medium other than air, the velocity of propagation on the transmission line is reduced. The velocity of propagation on such a line is equal to  $1/\sqrt{L(kC)}$ , where *L* and *C* are the inductance and capacitance per unit length along the line and *k* is the effective dielectric constant of the medium in which the line is immersed. This dielectric constant is a resultant of the total dielectric circuit surrounding the line.

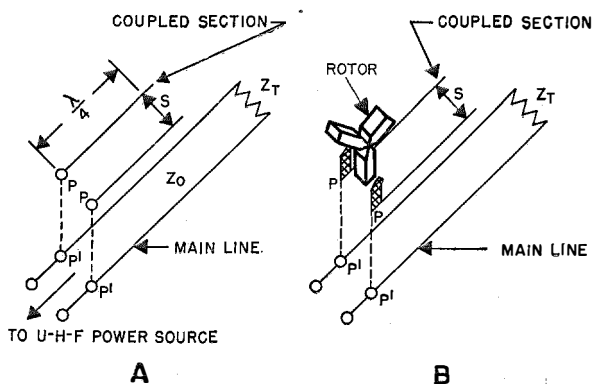

Fig. 39—Theory of mechanical modulator.

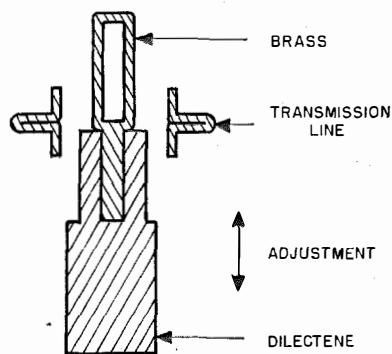

Fig. 40—Arrangement of materials in the adjustable insert of the phasing unit.

If the amount of solid dielectric material is decreased, the value of  $k$  is reduced towards unity thus increasing the velocity of propagation along the line.

The surge impedance of a loss-free transmission line is equal to  $\sqrt{L/(kC)}$ . If the magnitude of this quantity is allowed to vary as the dielectric material is changed, mismatches will occur. To avoid this difficulty, the removal of the dielectric material is accompanied by a simultaneous insertion of metallic material in a quantity to keep the surge impedance of the line constant. Fig. 40 shows the schematic mechanical arrangement of the transmission-line insert. It is not theoretically perfect but is a sufficiently close approximation to give the desired effects. The insert produces a total phase shift in the 12-inch transmission line of about 18 degrees at 109 megacycles. It is moved by means of a gear mechanism as shown in Fig. 41.

#### APPENDIX IV

##### 9 Derivation of Phase Shift Along the Glide Path as a Function of Distance from the Transmitting Antennas

Fig. 42 shows the distances which the various radiations from the glide-path antennas traverse in reaching some receiving point  $P$ . This receiving point, when viewed from the glide-path antennas, subtends a vertical angle approximately the same as the glide-path angle in question. Equations (19) and (21) express the complete signals from the upper and lower an-

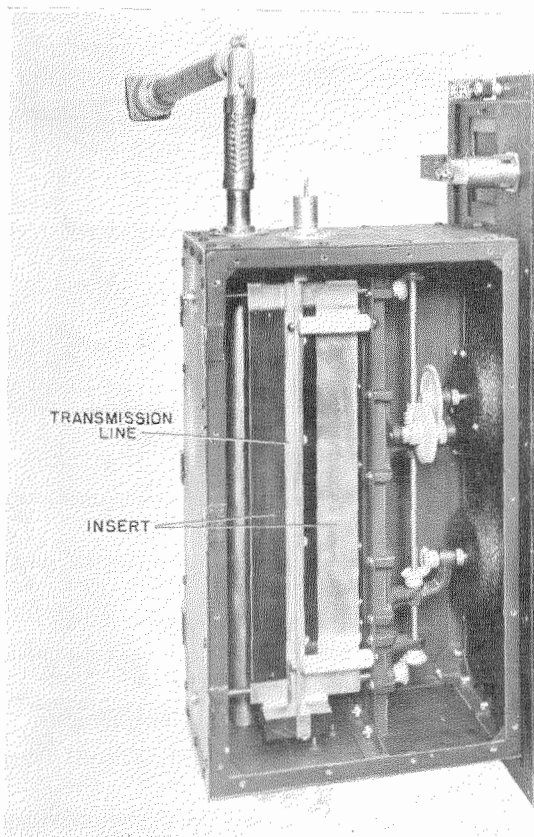
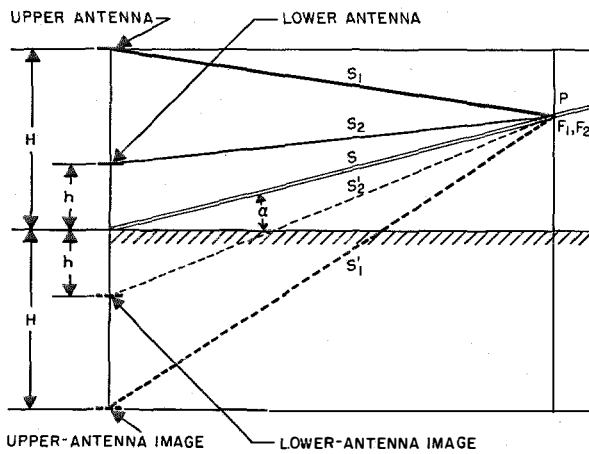

Fig. 41—Phasing unit with cover removed.

tennas which arrive at point  $P$ . By means of trigonometric and algebraic transformations, equation (38) can be obtained. Equation (38) shows that the carriers emitted by the upper and lower antennas shift phase with respect to each other as the equipment is approached directly. This phase shift varies as the square of the height of the antennas and inversely as the distance from them. From this equation it is clear that such a phase shift between carriers is greatly increased as the glide-path angle is lowered, which also means that the effect of the phase shift extends considerably farther from the radiation system. Equations (39), (40), and (41) have been included to show that a 70-degree phase shift occurs in traversing the distance from an infinite point on the glide path to a point 400 feet directly in front of the glide-path antennas set to produce a  $2\frac{1}{2}$ -degree glide path.



$H$  = distance of upper antenna or upper-antenna image from ground surface  
 $h$  = distance of lower antenna or lower-antenna image from ground surface  
 $S_1$  = phase shift of radiated signal from upper antenna  
 $S'_1$  = phase shift of radiated signal from image of upper antenna  
 $S_2$  = phase shift of radiated signal from lower antenna  
 $S'_2$  = phase shift of radiated signal from image of lower antenna  
 $S$  = distance, in electrical degrees, of airplane receiving antenna from a point on the ground directly below the antennas  
 $F_1$  = total signal of upper antenna and its image  
 $F_2$  = total signal of lower antenna and its image

Fig. 42—Phase relations of radiated signals from upper and lower antennas.

Refer to Fig. 42.

$$F_1 = \sin(\omega t + S_1) - \sin(\omega t + S'_1) \quad (19)$$

$$= 2 \sin\left(\frac{S_1 - S'_1}{2}\right) \cos\left[\omega t + \left(\frac{S_1 + S'_1}{2}\right)\right] \quad (20)$$

$$F_2 = \sin(\omega t + S_2) - \sin(\omega t + S'_2) \quad (21)$$

$$= 2 \sin\left(\frac{S_2 - S'_2}{2}\right) \cos\left[\omega t + \left(\frac{S_2 + S'_2}{2}\right)\right] \quad (22)$$

$$S_1 = \sqrt{(S \cos a)^2 + (H - S \sin a)^2} = \sqrt{S^2 - 2SH \sin a + H^2} \quad (23)$$

$$S'_1 = \sqrt{(S \cos a)^2 + (H + S \sin a)^2} = \sqrt{S^2 + 2SH \sin a + H^2} \quad (24)$$

$$S_1 = S \sqrt{1 - \frac{2H}{S} \sin a + \frac{H^2}{S^2}} \quad (25)$$

$$S'_1 = S \sqrt{1 + \frac{2H}{S} \sin a + \frac{H^2}{S^2}} \quad (26)$$

By binomial expansion (omitting higher-order terms)

$$S_1 = S \left(1 - \frac{H}{S} \sin a + \frac{1}{2} \frac{H^2}{S^2}\right) \quad (27)$$

$$S'_1 = S \left(1 + \frac{H}{S} \sin a + \frac{1}{2} \frac{H^2}{S^2}\right) \quad (28)$$

$$\frac{S_1 - S'_1}{2} = -H \sin a \quad (29)$$

$$\frac{S_1 + S'_1}{2} = S + \frac{1}{2} \frac{H^2}{S} \quad (30)$$

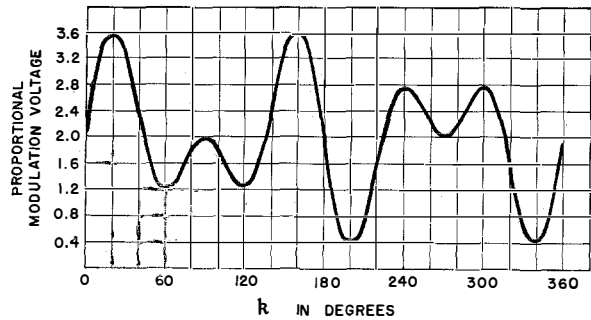

Detected envelope =  $F_T$   
 $= \sin \omega_0 t [1 + m \sin \omega_s t] + \sin(\omega_0 t + Q) [1 + m \sin \omega_s t]$

$Q = 0^\circ$

$m = 0.9$

$\omega_s t = 3 \times 360^\circ \times n = 1080^\circ n \quad n = \frac{k}{360^\circ}$

$\omega_c t = 5 \times 360^\circ \times n = 1800^\circ n$

Phase shift between carriers =  $0^\circ$

Ratio of audio modulation voltages to the direct voltage in the detector circuit = 90%

Ratio of cross-modulation voltages to direct voltage in the detector circuit = 0%

Ratio of second-harmonic voltage to direct voltage in detector circuit = 0%

Fig. 43—Detected envelope of 2 amplitude-modulated waves.

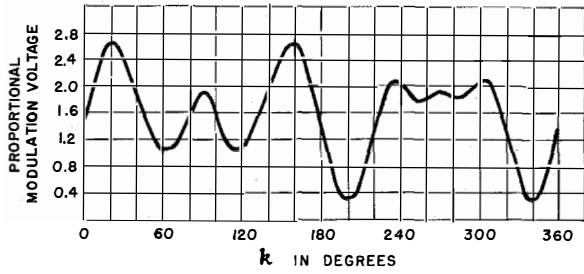

Detected envelope =  $F_T$   
 $= \sin \omega_0 t [1 + m \sin \omega_{s1} t] + \sin (\omega_0 t + Q) [1 + m \sin \omega_{s2} t]$

$Q = 90^\circ$

$m = 0.9$

$\omega_{s1} t = 3 \times 360^\circ \times n = 1080^\circ n \quad n = \frac{k}{360^\circ}$

$\omega_{s2} t = 5 \times 360^\circ \times n = 1800^\circ n$

Phase shift between carriers =  $90^\circ$ .

Ratio of audio modulation voltages to direct voltage in detector circuit =  $79\%$ .

Ratio of cross-modulation voltages to direct voltage in the detector circuit =  $15.4\%$ .

Ratio of second-harmonic voltage to direct voltage in the detector circuit =  $7.7\%$ .

Fig. 44—Detected envelope of 2 amplitude-modulated waves.

The following equation is obtained by substituting the values for

$\frac{S_1 - S'_1}{2}$ , and for  $\frac{S_1 + S'_1}{2}$  in equation (20).

$F_1 = 2 \sin (H \sin a) \cos \left( \omega t + S + \frac{H^2}{2S} \right)$ . (31)

The same mathematical analysis may be applied to the signal radiated from the lower antenna and its image, therefore:

$F_2 = +2 \sin (h \sin a) \cos \left( \omega t + S + \frac{H^2}{2S} \right)$ . (32)

$\phi_1 = S + \frac{H^2}{2S}$   
 = phase of the resultant radiation from the upper antenna and its image at point  $P$  with respect to the phase of the upper antenna. (33)

$\phi_2 = S + \frac{h^2}{2S}$

= phase of the resultant radiation from the lower antenna and its image at point  $P$  with respect to the phase of the lower antenna. (34)

The phase difference  $\phi_T$  between the resultant signals from the upper and lower antennas at any point on the glide path is equal to the phase difference between signals  $F_1$  and  $F_2$ .

$\phi_T = \phi_1 - \phi_2 = \frac{H^2 - h^2}{2S}$  (35)

but

$H = nh$ , (36)

( $n = 4.75$ , ratio of the height of the upper antenna to the lower antenna).

$\phi_T = \frac{h^2(n^2 - 1)}{2S}$ . (37)

$\phi_T = \frac{h^2(21.56)}{2S}$ . (38)

Phase relations of a  $2\frac{1}{2}$ -degree glide path,

$\phi_T = \frac{(565.3^\circ)^2(21.56)}{2S}$ , (39)

( $h = 565.3$  degrees = height (electrical degrees) of the lower antenna for a  $2\frac{1}{2}$ -degree glide path).

$\phi_T = \frac{6.88^\circ \times 10^6}{2S}$  (40)

at 400 feet from the radiation system.

$\phi_T = \frac{6.88^\circ \times 10^6}{2 \times 48,960^\circ} = 70$  degrees.

(At 335 megacycles,  
 400 feet = 48,960 degrees.) (41)

APPENDIX V

10 Graphical Analysis of Two Linearly Detected Modulated Carriers

Equation (42) represents 2 modulated carriers between which a phase shift  $Q$  exists. One carrier has a modulation frequency 3 times some arbitrary value  $k$  and the second carrier has a modulation frequency which is  $5k$ . Equation (45) is the expression for the modulation voltage which appears in a linear-detector output circuit when the 2 modulated carriers have been injected into

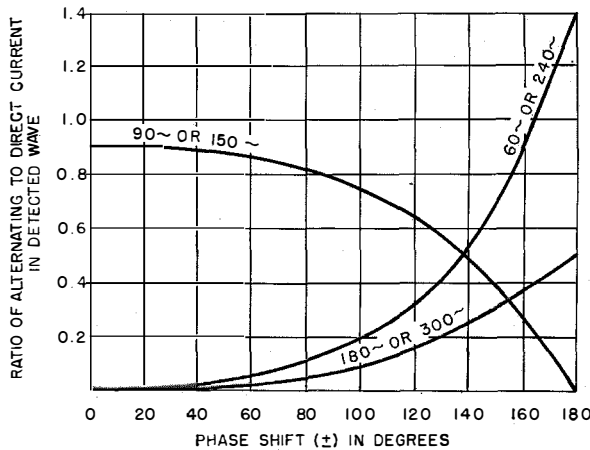

Fig. 45—Distortion in a modulated wave as a result of phase shift of carrier with respect to side bands.

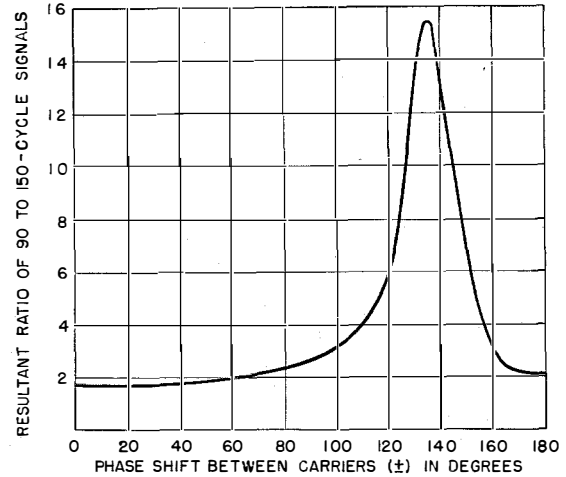

Fig. 46—Resultant ratio of 90-cycle and 150-cycle signals as a function of phase shift between carriers.

the input circuit. Using a percentage of modulation of 90, a fundamental audio modulation frequency of 30 cycles, and phase shifts varying from 0 to 180 degrees, curves were obtained from equation (45) as shown in Figs. 43 and 44. These curves were analyzed graphically. The results for various phase shifts from 0 to 180 degrees are plotted in Fig. 45. The curves show that phase shifts of approximately ±30 degrees between carriers produce practically no change in the amplitude of the 90- and 150-cycle frequencies and also that no appreciable amount of harmonic or cross-modulation frequencies are produced. Starting at about a 30-degree phase shift and continuing on to 180 degrees, the energy of the 90- and 150-cycle signals continually decreases, being converted mostly into cross-modulation energies as well as harmonic energies. It is clear that optimum range on the glide path can be obtained only when phase shifts between carriers are less than 30 degrees.

Equation (45) was used for the analysis of a modification of 2 modulated waves of different amplitudes in which phase shifts between carriers were varied from 0 to 180 degrees in 15-degree steps. This analysis showed the swamping effect which occurs in linear detectors under such conditions. Fig. 46 shows one of the most interesting cases. It is an analysis of the condition in which

the in-phase signal amplitudes have a ratio of 1.75/1. Such a ratio results in about the largest swamping effect.

### 10.1 EXPRESSION FOR 2 MODULATED CARRIERS IN WHICH A PHASE SHIFT $Q$ EXISTS BETWEEN CARRIERS

$$F_T = \sin \omega_0 t (1 + m_1 \sin 3k) + \sin (\omega_0 t + Q) (1 + m_2 \sin 5k). \quad (42)$$

$$F_T = \sin \omega_0 t (1 + m_1 \sin 3k) + \sin \omega_0 t (\cos Q) (1 + m_2 \sin 5k) + \cos \omega_0 t (\sin Q) (1 + m_2 \sin 5k). \quad (43)$$

$$F_T = \sin \omega_0 t [(1 + m_1 \sin 3k) + (\cos Q) (1 + m_2 \sin 5k)] + \cos \omega_0 t [(\sin Q) (1 + m_2 \sin 5k)]. \quad (44)$$

$$F_T = \sqrt{[(1 + m_1 \sin 3k) + (\cos Q) (1 + m_2 \sin 5k)]^2 + [(\sin Q) (1 + m_2 \sin 5k)]^2}. \quad (45)$$

$m_1, m_2$  = percentages of modulation

$Q$  = phase shift between carriers

$k = 30$  cycles, the fundamental frequency common to both 90 and 150 cycles.

$3k = 90$  cycles

$5k = 150$  cycles.

# Applications of High-Frequency Solid-Dielectric Flexible Lines to Radio Equipment

By H. BUSIGNIES

*Director, Federal Telecommunication Laboratories, Inc., New York, New York\**

## Summary

**P**RESENT and past needs for flexible moisture-proof radio-frequency lines are reviewed. Their importance in ship and airplane installations, and in ground equipments requiring easy assembly and disassembly is discussed. A plastic based on polystyrene was used as a dielectric in flexible coaxial or dual lines before polyethylene was available in large quantities.

The mechanical and electrical requirements are outlined. Special requirements of electrical balance, or specific electrical length, imposed by the design of some radio equipments using very large quantities of cable, are described together with methods of testing the cables. Values of attenuation and voltage breakdown are given as well as requirements of electrical balance or constancy of velocity of propagation.

Examples of two radio equipments utilizing flexible lines are the SCR-291 direction finder, which employs balanced RG-23-U cable in particularly exacting conditions, and the SCS-51 instrument landing system where the same cable is used between antennas and transmitters.

The application of this type of cable to these equipments is discussed. The SCR-291 direction finder would have been impossible without a highly balanced and accurately tested cable such as the RG-23-U.

The applications of radio-frequency flexible cables are large and various and include almost every radio equipment.

## 1. Introduction

During the few years preceding the war, flexible high-frequency transmission lines were used for connecting antennas to receivers and low-power transmitters, including loop antennas and direction-finding equipment; for connections between different panels of a radio installation; and for connections between signal generators,

\* Formerly Federal Telephone and Radio Laboratories, Inc.

vacuum-tube voltmeters, and equipment under test.

The rigid type of line is very inconvenient and in the past use was made of ordinary rubber-insulated wires, single or balanced, covered with flexible braid; beaded lines; and some lines having a flexible low-loss solid dielectric between the shield and the conductor or conductors.

The above solutions were unsatisfactory for various reasons. The beaded lines were fragile, absorbed moisture, and showed irregularities of electrical characteristics. The large losses at high frequencies in rubber-insulated lines made them useful only for very short connections.

The first attempts to construct solid-dielectric lines were not too successful. Large variations in electrical characteristics were observed. Aging of the dielectrics resulted in progressive loss of mechanical and electrical qualities. The mechanical qualities could not be maintained over a wide range of temperature.

The war called for military equipments which could be assembled and disassembled in a short time, and their design required moisture-proof flexible transmission lines having low losses up to the ultra-high-frequency spectrum.

Before polyethylene was commercially available, the engineers of Federal Telephone and Radio Corporation developed a plastic based on polystyrene, coded IN-45. Fortunately, cables using this material were quite satisfactory for radio purposes and were produced in large quantities. The general introduction of polyethylene in 1943 resulted in a further improvement particularly with respect to the uniformity of characteristics. However, some of the previous compounds, although less uniform, were better for some purposes and, in particular, kept their mechanical qualities over a wider range of temperature.

A large percentage of radio equipment makes use of solid-dielectric cables, mainly between the wave collector or radiator and the radio

equipment proper. These applications and the problems which have been solved, or that remain to be solved in connection with them, will be described.

## **2. Flexible Solid-Dielectric Cables in Radio Design**

It is now very exceptional in radio design for the radiator or the wave collector to be located near the radio equipment. The number of transmitters, receivers, or directive devices to be connected to antennas, obliges the designers to spread the various antennas over an area which, moreover, for ultra-high frequencies, must be elevated.

A typical case is that of a ship installation where the radio equipment is inside the ship and the radiators and wave collectors are on the superstructure. The location of the transmission lines and the vibration to which they are subjected makes the installation of a rigid air-dielectric line almost entirely impracticable. Protection against moisture by keeping a neutral gas in the line at greater than atmospheric pressure presents extremely difficult maintenance problems; repairs are very involved or impossible.

The advantages of the ideal solid-dielectric line are very obvious. However, the exacting conditions under which cables have to operate resulted in a considerable period of trial and adaptation to produce adequate cables.

On airplanes the lengths of cable are shorter, but the importance of flexibility is just as great. Light and small cables have to follow the structure of the fuselage or wings and may be subject to many sharp bends.

The general use of shock mounting for radio equipment requires a flexible connection between the apparatus and the airplane. The extreme ranges of temperature and pressure inside airplanes cause rigid air-dielectric lines to absorb moisture and also impose stringent requirements on flexible solid-dielectric lines. Automotive equipments show problems of the same general nature.

In ground equipments, while rigid air-dielectric lines may be every effective, at least for fixed installations, the use of flexible lines facilitates installation of the equipment.

The design of certain radio equipments was predicated on the availability of flexible solid-

dielectric lines. Under this pressure, considerable progress has been made in the design and manufacture of such cables.

To meet the electrical requirements of radio equipments, several cables of very different characteristics had to be developed. Direction finders and instrument landing systems need highly balanced transmission lines. Some other equipments require high-impedance coaxial lines, low-capacitance lines, attenuating lines, and large-diameter power lines. However, the standardization of characteristics and materials proposed by the Army and the Navy has been carried out to a satisfactory degree.

Connectors which would not impair the advantages of the flexible line had to be developed. A connector must make good electrical contact and be waterproof. It should be attached to the cable very readily, and be capable of being connected and disconnected many times without failing to operate. For very-high frequencies, the connectors should not introduce variations of impedance greater than certain values which are generally expressed in percentage of standing wave. The solid-dielectric cable has a breakdown voltage higher than that of a corresponding air-dielectric line and, therefore, connectors used on transmitters had to be very carefully designed to retain the voltage capacity of the cable.

## **3. Requirements Applying to Flexible Solid-Dielectric Lines**

The mechanical and electrical requirements, which depend on the service expected from the cable, will be treated separately. However, mechanical requirements are always expressed in terms of variations of the electrical characteristics. Only the most stringent requirements will be considered.

### **3.1 MECHANICAL REQUIREMENTS**

Coaxial lines to be used with transmitters or receivers must meet the following requirements.

**3.1.1 Aging.** When a load is applied to the inner conductor of a bent cable or after a number of bendings, at a temperature of 75 degrees centigrade, the inner conductor of the cable should not move more than a very small fraction of its diameter. The cable is tested after this high-temperature aging to determine that there is no

loss of flexibility or cracks in the dielectric or jacketing material. This requirement is particularly important for cables operating inside a ship, under warm climates, or exposed to the sun for long periods of time, and is one of the most exacting tests.

**3.1.2 Cold Bending.** It should be possible to bend the cable a number of times at a temperature of  $-40$  degrees centigrade without evidence of cracks or fracture in the core or jacketing material.

**3.1.3 Flow Requirements.** When a load, determined by the dimensions of the cable, is applied to the inner conductor of a bent cable, that conductor should not move from its original position more than a small percentage of the thickness of the core.

**3.1.4 Miscellaneous.** The cables should be gas-line resistant. The jacketing must be entirely waterproof, flame resistant, and capable of withstanding many successive bendings without rupture or excessive variation of the electrical characteristics.

## 3.2 ELECTRICAL REQUIREMENTS

While the above mechanical requirements generally apply to all types of cables, the electrical requirements will vary with the application.

**3.2.1 Transmitting Systems.** In cables for large powers at high frequencies, the prime requirements will concern losses and breakdown voltage. Next in importance will be uniformity of impedance. The highest quality of polyethylene is prescribed for this case while a lower grade might be accepted for lower frequencies or short lengths of cable.

In the high- and very-high-frequency spectrums the loss in the dielectric is not as important a factor as the losses in the inner conductor and, particularly, in the braid. In the ultra-high-frequency spectrum the loss in the dielectric becomes more important than the loss in the braid. The losses in the dielectric are approximately of the same order as the losses in the braid around 300 megacycles per second for cables of 50 to 70 ohms impedance.

The breakdown voltage is generally many times higher than the test voltage. For the

straight double-coaxial-line balanced RG-23-U cable, the high-voltage test is made at 10,000 volts, while breakdown occurs at a voltage 8 to 10 times greater.

The following figures give the order of attenuation observed on a cable of the type RG-23-U:

Frequency in Megacycles per second	Attenuation in db per 100 feet
10	0.4
30	0.8
300	3.5

An increase in losses takes place near or within the range of voltage at which corona develops. Corona will occur at a lower voltage if there are air bubbles in the core and special precautions are taken to avoid them. Variations of temperature affect losses and stability of impedance.

The cable will satisfy the requirement of  $\pm 4$  percent maximum variation of impedance and this is under control during production.

**3.2.2 Receiving Systems.** For coaxial cables, the most important requirements concern losses and variation of impedance. The best grade of polyethylene will be used for very-high and ultra-high frequencies. Very often, cables of small diameter, generally designed for receiving systems, are used to transmit a certain amount of power. There is really no clean-cut distinction between cables for receivers and for transmitters except for the special class of very-high-power cables. The observations on losses in the braid and dielectric apply to both.

In one instance, a type of balanced cable developed for a direction finder was successfully used for transmission in a directive system. For such use, the variation of impedance is important as the antenna must be matched over what is often a wide band of frequencies.

On ultra-high frequencies, it is relatively easy to design wide-band transformers to transfer energy from balanced to unbalanced cables or networks. These transformers are not as practical or satisfactory on lower frequencies and, in particular, in the high-frequency spectrum.

As many antennas in the high- and very-high-frequency fields are inherently balanced, it is necessary to connect them to the receiver through a balanced transmission line. This permits easy cross connection between a number of cables to obtain, for instance, desired directivity effects



in an antenna system. Most of the direction finders operating between 2 and 30 megacycles per second use balanced wave-collector systems.

The ability to pick up energy from an outside field is much less for a balanced line than for a coaxial line at frequencies for which the current does not flow strictly on the inside of the outer conductor. Balanced lines are also convenient on very-high and high frequencies in connection with balanced wave collectors or radiators, particularly if they are designed to operate on only one well-defined type of polarization.

In the best designs available in 1941, the percentage of unbalance on high frequencies for lengths of the order of one or two wavelengths was about 10 to 25 percent. Further development of cables and special testing equipment<sup>1</sup> brought this figure down to 0.5 to 1 percent, and resulted in an increase in the quality of all types of cables.

One type of line, which has wide application, could be bent only in one axis because it is made of two parallel coaxial cables braided together.

If proper precautions are taken during manufacture, twisted coaxial cables can have very satisfactory values of balance. This design was found advantageous in keeping balance under any conditions of handling and bending. Such cables have been developed for special installations in which balance must be maintained for many different positions of the cable. While twisted cables have been developed for large production, so far only the parallel-type of balanced cable has had wide application.

In some cases, it is necessary to use a number of cables of equal electrical length to obtain exactly the same phase shift on all sections or, when sections of different lengths are involved, to obtain a certain phase-shift relation between sections. To satisfy this, not only the propagation on the two conductors should be alike on a certain length of balanced cable, but different lengths of the cable should show the same velocity of propagation within very narrow limits.

Under present electrical requirements, cable may be cut at the same physical lengths to obtain equal electrical length within narrow limits; if

<sup>1</sup> N. Marchand, "Special Aspects of High Frequency Flexible Balanced Cables," *Electrical Communication*, v. 22, n. 3, p. 193, 1945.

a higher degree of similitude is required, the cables are cut to the same electrical length using special test equipment.

#### 4. General Testing Methods

To satisfy the requirements described above, very extensive testing methods have been developed and will be reviewed briefly.

Chemical testing and all the precautions involved in the inspection of raw materials will not be discussed. It should be noted that the diameter of the conductors and the composition of the dielectric are of such importance as to justify careful inspection. If the necessary precautions are taken to insure constancy of position of the inner conductor and of the diameter of the core, the resulting cable will meet most or all of the normal requirements for general use but may not maintain the impedance or balance essential for special applications. The general problem of testing divides into four categories. We will not deal with 4.1.1 and only briefly with 4.1.2 and 4.1.3.

##### 4.1 INSPECTION OF MATERIAL AND CONTROL OF PHYSICAL DIMENSIONS

*4.1.1 General Mechanical Testing.* The factory is equipped with cold and hot chambers and accessories to test for flexibility, bending at low temperatures, etc.

*4.1.2 General Electrical Testing.* Cables, even for receiving equipments, are subjected to a corona test and a high-voltage test. The two other most important general electrical tests are for impedance and losses. Both are factory measurements and are made at a fixed frequency with equipment developed co-operatively by engineers of the Intelin Division and Federal Telecommunication Laboratories.

*4.1.3 Special Testing.* Special testing will insure that cables, which have already been checked for general use as mentioned above, can meet additional requirements for special applications like polarized transmitting antennas or direction-finder wave collectors.

Equipment was developed to record rapidly the figure of balance of a length of cable over the wide frequency spectrum from 3 to 27 megacycles per second. A generator, connected to one

end at the cable, scans this frequency range while at the other end the receiving equipment records directly the ratio between the sum and difference of the transmitted voltages on the two wires. The figures are expressed either in ratios or in percentages (50/1 or 2 percent).

Measurement devices, generally based on resonant frequency, are used to adjust a line to a particular electrical length for application to a specific radio equipment.

For one direction finder, the cables have to be cut to within  $\frac{1}{4}$  inch of an electrical length of 80 feet, which is of the order of 0.02 percent. The balance needed is 33/1 or 3 percent, minimum. The accuracy of the test equipment satisfies this requirement. Specifications, a little less stringent, apply to the shorter lengths of cable used between the radiator and transmitter in the localizer and glide-path equipment of an aircraft instrument landing system.

A common requirement in some other applications is 50/1 or 2 percent unbalance on a cable one wavelength long and 0.5 electrical degree for a cable several wavelengths long.

These methods of testing have provided considerable information for the improvement of radio equipment which, in turn, has called for more accurate testing methods.

5. Examples of Applications

The applications of solid-dielectric flexible lines to radio equipments are unlimited. Every radio engineer can foresee the use of flexible lines in the design of transmitters, receivers, direction finders, and directive devices. As it is not possible to review all cases in which solid-dielectric lines provided the solution to problems of disposition or installation, only two typical examples of radio equipments, the design of which was dependent on the availability of these cables, will be described briefly.

The SCR-291 direction finder, used by the Army Airways Communications System to provide accurate bearings for military pilots on world-wide air routes, uses a 5-monopole antenna system installed at a distance from a receiving and distance-indicating station as shown in Fig. 1. To reduce polarization errors and the

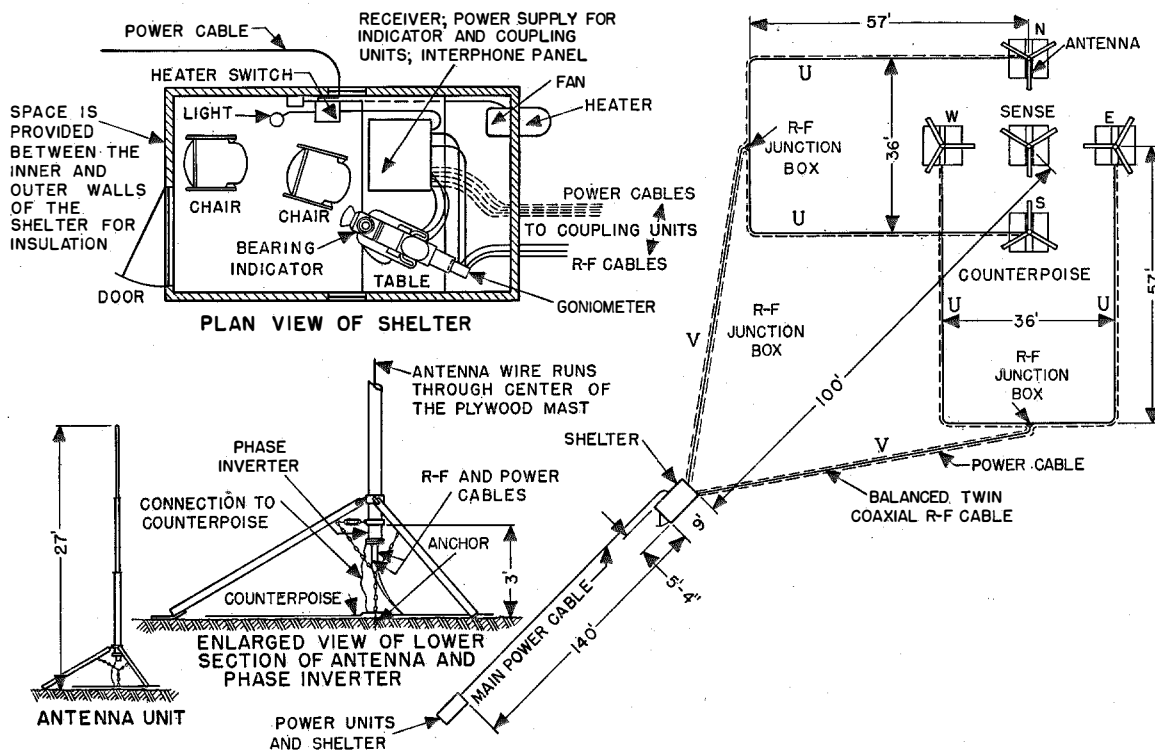

Fig. 1—Plan of direction-finder site, giving detailed disposition of components with dimensions

influence of the shelter on the antenna system, the antennas were connected to the receiving equipment through a set-up of flexible lines which could be laid or coiled on the ground in a minimum of time and operate properly irrespective of temperature and weather variations. When this development was started, a suitable type of line did not exist. A balance of 50/1 was necessary for each cable. The electrical lengths for the "U" and "V" cables of Fig. 1 had to be equal within  $\frac{1}{4}$  inch for 80-foot lengths thus providing for interchangeability of cables and spares. These radio-frequency transmission lines, in connection with a phase inverter or coupling unit at the base of each antenna, provided a very successful transmission system which made possible an accurate direction-finding antenna array. A very minimum of difficulties has been reported in connection with their use.

All the cables are tested at the factory for electrical length and must be interchangeable. Fig. 2 shows the receiver, indicator, and power supply of the SCR-291 direction finder; these units are installed in the remote shelter (see Fig. 1). Fig. 3 shows the base of the center antenna of the wave-collector system. Entering the coupling unit are three cables, one power cable (small diameter) and two radio-frequency cables, RG-23-U. Waterproof plugs were especially designed for this application. The two radio-frequency cables are necessary for the sense circuit used. The other antennas are very similar except that only one radio-frequency and one power cable are connected to the coupling unit. The antenna proper is a wire mounted inside a vertical plywood tube. These antennas were designed for quick installation.

The cables are transported on reels; each section is assigned to a given reel with the plugs

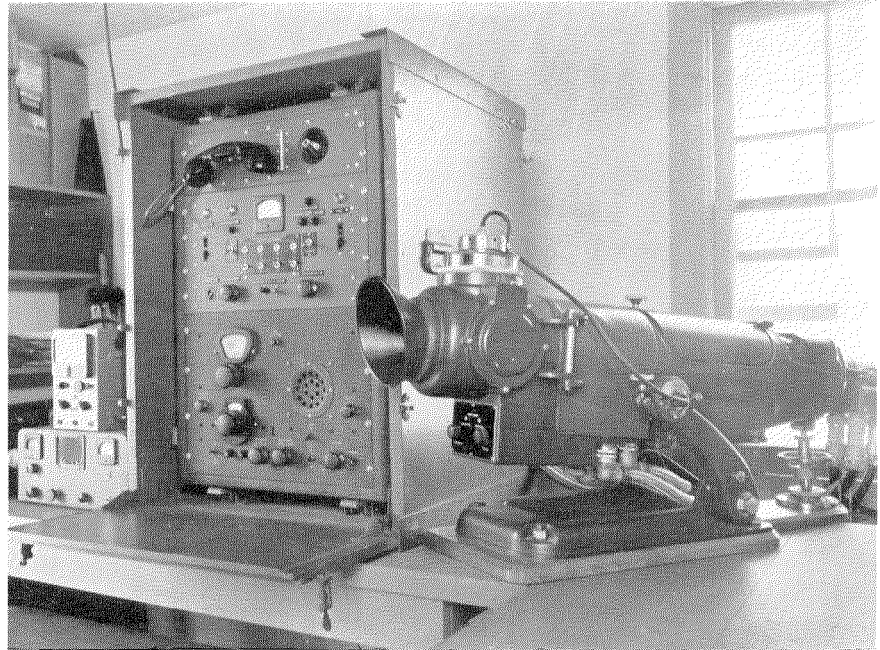

Fig. 2—The receiver, indicator, and power supply of the SCR-291 direction finder. This terminal equipment is connected to the antennas by solid-dielectric flexible cables.

suitably protected for transportation. In such an installation one can imagine the type of handling that accidentally or regularly befalls the radio-frequency cable.

The total parasitic pick-up on the whole transmission line system is so low that it cannot be measured accurately.

It is interesting to note that when the development of the prototype of the SCR-291 was started, no line was available to meet the requirements; polyethylene was not yet available in sufficient quantity. The equipments were produced with lines insulated with a plastic based on polystyrene and coded IN-45. The availability of this compound and the design early in 1942 of a satisfactory balanced line made possible the rapid production of this equipment.

When this cable was made available, it was also found to be suitable for connecting the various radiators used in the glide-path and localizer equipment of the SCS-51 instrument landing system of the Army Air Forces. These two instruments also required balanced lines of very accurate electrical length. The same line, originally made with the polystyrene compound and later with polyethylene, was employed.

The localizer equipment of the SCS-51 instru-

ment landing system produces an ultra-high-frequency radio beam aligned with the airport runway.

Five balanced loop antennas radiate horizontally polarized waves. The length of the lines connecting them to the transmitting equipment determines the phase of the energy transmitted from each loop. The length of the lines must be adjusted to within a few electrical degrees out of about 5,000 and this is done on test equipment working on the operating frequency of the localizer.

The electrical balance is generally tested on the high-frequency test equipment as it has been found that the wide-band testing (3 to 27 megacycles per second) provides most of the information needed even for frequencies far distant from its maximum range.

The glide-path equipment uses two radiators, one substantially higher than the other. The cable of the high antenna has a total electrical length of 5,090 degrees. After two connectors have been added, the electrical length must be within  $\pm 5$  degrees, which is one part in a thousand.

The balance measurement on the cable under these conditions indicates that sometimes there are variations in electrical length between the two conductors of  $\pm 10$  degrees. This measurement is made by noting the displacement between nulls on an open-wire balanced line.

The cable for the low antenna being shorter, it is cut entirely by physical measurements, but is tested for electrical length, which is about 1,405 degrees. After the attachment of connectors to each end, its total electrical length may vary only  $\pm 5$  degrees. A balance measurement on this cable indicates a difference in electrical length between the conductors of about  $\pm 2.5$  degrees.

In the examples cited above, the requirements placed on the radio-frequency cables are much more exacting and complex than in the case of the mere connection of a receiver or a transmitter to an antenna. Except for

losses, which still prevent their use for long distances on ultra-high frequencies, these solid-dielectric lines are comparable to the highest quality of air lines presently available.

## 6. Conclusion

While the idea of a solid-dielectric flexible high-frequency transmission line is relatively old, its practical development, as stimulated by military requirements, makes it a product of this war. Its availability has permitted certain designs which otherwise would not have been practical. The convenience it offers in interconnecting the essential parts of an installation and for signal circuits within a single assembly indicates a wide future application for such cable.



*Fig. 3—The connections to the base of the center antenna of the wave-collector system may be seen above. Two flexible solid-dielectric lines are used.*

## Rotary Automatic Equipment to be Installed in Lexington, Kentucky, and Rochester, New York

**T**WO contracts, noteworthy inasmuch as they will introduce the Rotary Automatic Telephone System into the U. S. A., were recently negotiated by the Federal Telephone and Radio Corporation. The first of these contracts was signed with the Lexington Telephone Company, Lexington, Kentucky, July 10, 1945. The second contract, with the Rochester Telephone Corporation, Rochester, New York, was signed October 29, 1945.

The complete equipment for the Lexington Telephone Company, subsidiary of the General Telephone Corporation, including toll boards and comprising 15,000 lines serving 25,000 subscribers, will be installed by FTR in a main office building to be erected in Lexington. Inauguration of the new office, of the 7A-2 type, is planned for the middle of 1947. Mr. L. O. Evenson, Vice President and General Manager of the Lexington Telephone Company, stated: "This move marks the initial step in our company's postwar plans to convert its system from manual to modern dial service. It will bring about greatly improved service, as the Rotary Automatic System embodies some of the most modern advancements in telephony."

For the Rochester Telephone Corporation, the initial equipment, also of the 7A-2 type, will consist of 15,000 lines serving 23,000 subscribers. Installation will commence immediately on completion of a new central office building. Ultimate plans in the conversion program from manual to automatic operation provide for the installation of 55,000 lines. Approximately 140,000 telephones are served within a 50-mile radius. Rochester has one of the highest telephone developments in the U. S. A. (30 telephones per hundred) and was one of the first communities to place its outside wire plant underground.

To date, I. T. & T. associate companies have installed over 2,000,000 lines of Rotary automatic equipment in many of the larger cities of Europe, such as Paris, Marseilles, Brussels, Antwerp, Budapest, Bucharest, Copenhagen, Oslo, Madrid, The Hague, and Zurich, as well as

in Italian and North and South American cities, and elsewhere throughout the world. The major portion of this equipment has been manufactured by the Bell Telephone Manufacturing Company of Antwerp.

Rotary is the standard system of The International Telephone and Telegraph Corporation. Administrations and other operating organizations that have adopted Rotary for general or partial use in their respective networks include:

- Norwegian Telephone and Telegraph Administration
- Copenhagen Telephone Company
- Dutch Government
- New Zealand Government
- \*Shanghai Telephone Company
- Chinese Government
- Belgian Government
- \*\*National Telephone Company of Spain
- \*Mexican Telephone Company
- Bergen Telephone Company
- Hungarian Government
- \*\*Rumanian Telephone Company
- Swiss Government
- Bermuda Telephone Company
- Brazilian Telephone Company
- Egyptian Government
- French Government
- One of the Italian Zone Administrations
- \*Peruvian Telephone Company
- \*Porto Rico Telephone Company

FTR has manufactured Rotary equipment of the Rochester and Lexington type for Puerto Rico and Brazil, and has contracts calling for the installation of additions to the same type of equipment in Mexico and Peru. Currently, FTR is tooled up to produce on a single-shift basis 100,000 lines of automatic equipment annually and its program calls for an increased capacity up to 200,000 lines annually at the earliest practicable date.

\*I. T. & T. associate company.

\*\*As a result of sale, no longer comprised in the I. T. & T. System.

# Tropical Moisture and Fungi: Problems and Solutions

By E. S. McLARN

*International Standard Electric Corporation, New York, New York*

HARRY OSTER and HENRY KOLIN

*Federal Telephone and Radio Corporation, Newark, New Jersey*

A. NEUMANN

*Federal Telecommunication Laboratories, Inc., New York, New York\**

*Editor's Note: Tropicalization of equipment is a problem that long has engaged the attention of communication engineers. Moreover, war requirements and the consequent utilization of complex equipment in far-flung tropic islands, as well as arctic regions, emphasized the greater need for protection against adverse atmospheric and other conditions. Efforts to determine causes of trouble and to find solutions were thus pressed by many workers. The present article represents an attempt to discuss the problem comprehensively and to indicate solutions which may prove useful.*

## 1 Introduction

THE effects of fungi and moisture on the life and performance of electrical equipment have received attention from engineers for more than a century. In 1838, John Bethell received a British patent on the protection of wooden poles by creosoting, and although research in this broad field has since been continuous, most attention appears to have been given to the preservation of fabrics. More recently, intensive study has been directed to the tropicalization of electronic and communication equipment used by the Armed Forces in the equatorial regions.

Oil companies as early as 1925 experienced difficulties with electronic apparatus used in their explorations for oil in the southern United States, Mexico, and South America. One such report<sup>1</sup> concluded that the chief difficulties with the electronic equipment of the geophysical groups (making seismographic surveys for oil) operating in the tropical areas were caused by moisture entering the insulation of the components, the attendant electrical leakage and corrosion resulting in open or short circuits. Their experience in the worst tropical areas

indicated that these difficulties could be eliminated by: (a) the correct choice of insulating materials, (b) driving moisture out of the individual components and sealing them with various impregnating and protective coating materials, and (c) protecting the circuits and components from dust and water by weatherproof cases.

## 2 Military Equipment

In the latter months of 1942 and early in 1943, reports were received by the Armed Forces indicating that the failure of radio and wire communications equipment in the Pacific theater, as a result of moisture and fungi, had reached serious proportions. Similar difficulties had been experienced by the British at Port Moresby and New Guinea. A partial list of the components and equipments which failed follows:

Antennas	Dynamotors	Relays
Batteries	Flashlights	Resistors
Cables	Jacks	Shelters
Capacitors	Keys	Speaker Cones
Cases	Lenses	Switchboards
Chests	Masts	Switches
Chokes	Meters	Telephones
Coaxial Cables	Motors	Terminal Strips
Coils	Optical Instruments	Test Equipment
Connectors	Plugs	Towers
Cords	Power Units	Transformers
Crystal Units	Radar	Tube Sockets

The material generally used in the above components which are most affected by tropical conditions are listed below:

\* Formerly Federal Telephone and Radio Laboratories, Inc.

<sup>1</sup> D. H. Gardner and J. S. Watts, "Difficulties Encountered with Electronic Equipment in Humid Climates," Humble Oil and Refining Company, Two Editions (1942, 1944).

TABLE I  
EFFECTS OF TROPICAL CONDITIONS ON MATERIALS

Part or Material	Effects of Moisture and Fungi
Fibre: Washers and supports, etc.	Swells, causing the supports to misalign, resulting in binding of supported parts; attacked and destroyed by fungi.
Fibre: Terminal strips and insulators. Laminated Plastic: Terminal strips and boards, switchboard panels, tube sockets, and coil forms. Molded Plastics: Terminal strips and boards, switchboard panels, connectors, tube sockets, and coil forms. Cotton, Linen, Paper. Cellulose Derivatives: Insulation, coverings, webbing, belting, laminations, etc.	Volume and surface resistivity are greatly reduced resulting in electrical leakage and flashovers which form carbonized paths between points of different potentials. Such destruction of insulating materials leads to misalignment of electrical circuits and eventual total failure.
Wood: Cases, houses and housings, plastic fillers, masts, etc.	Dry rot, swelling, delamination, loss of tensile strength.
Leather: Straps, cases, gas-kets, etc.	Fungi destroys tanning and protective materials causing rotting due to moisture and bacteria.
Glass: Lenses, windows, etc.	Settled organic dust provides nutrient for fungi which cause surface etching thereby destroying optical properties.
Metals	Corrosion as well as local electrolytic action between dissimilar metals.
Wax: For impregnation.	Organic waxes support fungi, causing destruction of insulating and protective qualities, and permitting entrance of moisture.

A detailed analysis of component failures, resulting in an alarmingly high proportion of equipment breakdowns, indicated predominant difficulties as follows:

### 2.1 POWER TRANSFORMERS

With open-coil types of power transformers, water is absorbed through voids in the insulating varnish impregnation thereby lowering the electrical resistance. The small separation between high-voltage windings is broken down,

forming a conductive carbon track. It is quite common for the insulation resistance between windings to be reduced from megohms to a few ohms after a relatively brief exposure to tropical conditions.

### 2.2 AUDIO TRANSFORMERS

Similar difficulties are encountered as with power transformers, except that the very fine copper wire used renders the component more susceptible to deteriorating actions.

### 2.3 CAPACITORS

The ordinary paper-wrapped, wax-coated, tubular paper capacitor is unsatisfactory since moisture rapidly lowers the insulation resistance. Metal-cased and molded mica capacitors have proven quite satisfactory except for difficulties in securing moisture-proof seals at the entrance points of the lead-in wires.

### 2.4 RADIO-FREQUENCY COILS

Radio-frequency inductors are badly affected by humidity. Leakage paths become evident between turns of the winding when paper-base phenolic tube or sheet is used. The  $Q$  of the coil is markedly lowered by this leakage and particularly by moisture absorbed by the coil forms.

### 2.5 DRY BATTERIES

The high humidity causes saturation of the cardboard containers, dissolving the gums used on them. Terminals in contact with the cardboard are thus connected with leakage paths which drain the battery. The moisture also corrodes the zinc electrode.

## 3 Tropical Conditions

While the foregoing equipment, materials, and components had operated to complete satisfaction in temperate climates, they failed to stand up in tropical areas. The tropical climate exposed electrical equipment to a combination of severely adverse conditions.

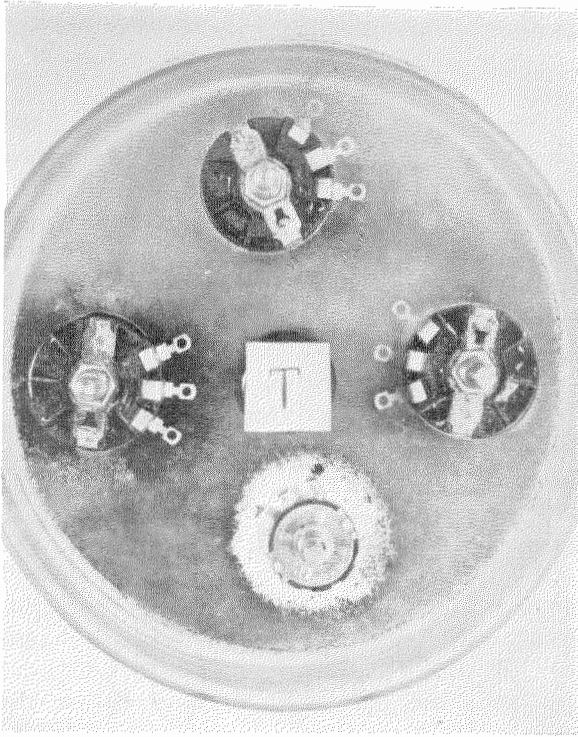

*Potentiometers undergoing fungus-resistance tests after several days in spore-inoculated agar solution. An adequately treated unit at the bottom is surrounded by an area of inhibition.*

### 3.1 HUMIDITY

In the areas north of Australia, specifically Milne Bay, records show that the humidity rarely falls below 70 percent, often rising to 100 percent, and averaging 90 percent. In many of the Pacific islands, humidity averaging 95 percent has been reported. In some coastal regions, a high atmospheric salt content accelerates corrosive action.

### 3.2 RAINFALL

In New Britain, the recorded rainfall is 150 to 250 inches per year, while rainfall as high as 400 inches per year has been noted in some tropical localities. Under combat conditions, the men in the field have to contend not only with rain but also surface water and seepage.

### 3.3 TEMPERATURE

The temperature often ranges as high as 54 degrees centigrade (130 degrees Fahrenheit), and seldom drops below 21 degrees centigrade (70 degrees Fahrenheit) even at night. This creates a condition extremely favorable to the propagation of living organic matter.

During a daily cycle the temperature may fluctuate as much as 17 degrees centigrade. This not only induces surface condensation of moisture but causes equipment cases, shield cans, and similar containers to "breathe" by expelling air in the daytime and sucking in moisture-laden air at night, thereby condensing moisture within the interior of enclosures.

## 4 Organic Matter

### 4.1 DUST

The abundant and luxuriant growth of trees, plants, grass, and other tropical flora results in a high proportion of minute particles of vegetable organic matter being dispersed in the air. This dust or debris settles on surfaces, cracks, or in apertures of components and supports the growth of fungi, even on materials which would not by themselves provide a focal point for such growth.

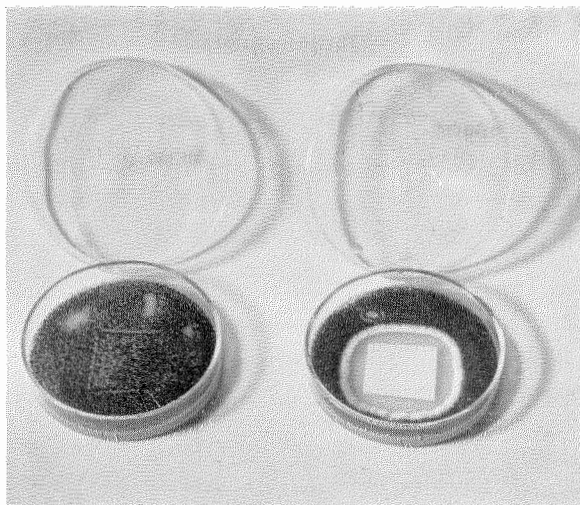

*Fungicide tested in Petri dish, showing area of inhibition. Untreated control at left.*



#### 4.2 INSECTS

Optical systems sealed against fungi are penetrated by minute insects, such as tropical mites, carrying fungus spores. Acid secretions from the deposited fungi eventually etch the glass surfaces.

#### 4.3 FUNGI

There are estimated to be at least 100,000 varieties of fungi, classified as a subdivision of the plant phylum known as Thallophytes, characterized by their growth in irregular plant masses structurally undifferentiated. Fungi include many of the lower forms of plant life, are devoid of green coloring matter (chlorophyll) and reproduce usually by spores. Because of the absence of chlorophyll, fungi are unable to synthesize carbohydrates from the carbon dioxide of the air. Therefore, they are dependent on other plants or animals for supplies of carbohydrates and sometimes for organic compounds of nitrogen. These supplies are obtained from living organisms by parasitic fungi, or more commonly from their dead or decaying remains by fungi termed saprophytes. Similar supplies may be obtained by certain types of fungi or molds from wood, glue, fabric, paper, some plastics, fibre, wax, and cellulosic derivatives.

Fungi may be unicellular or multicellular. Some grow as one-celled organisms for a time, becoming multicellular later under changed conditions. When multicellular they are composed of cells arranged end-to-end to form filaments or hyphae, which branch, rebranch, and intertwine, usually uniting or anastomosing to form a tissue called a mycelium. The mycelium may form a loose network as in molds or a compact, orderly arranged, tissue as in mushrooms. While fundamentally of the same structure throughout, they show extreme variations in external appearance as a result of the degree of compactness of the mycelium, availability

of food, temperature of growth, and inherent color characteristics. The cell walls are formed of cellulose, chitin, etc.

The mycelium grows along the surface of the host substances filling interstices and crevices. Food is obtained by simple absorption of material through the cell walls of the mycelium. On solid organic substrate, dissolving enzymes must first be secreted. On a complex substance, often several species will be living together in an arrangement in which one species may have enzymes capable of partially breaking down the substance, while other species carry the breakdown process further; such a phenomenon is known as symbiosis. Certain endoenzymes further reduce, oxidize, or otherwise chemically change the food to digest it.

Any part of a plant may grow and break off to form a free cell capable of forming a new plant. While this causes rapid dissemination, such cells are not equipped to maintain life in a dormant condition for any length of time, as are the spores. These are formed in germ-tube portions of mycelium extending into the air, forming and discharging reproductive bodies or spores which are very constant in structure and characteristic for each species. The mycelial germ-tubes may be either sexual or asexual, many species alternating from generation to generation.

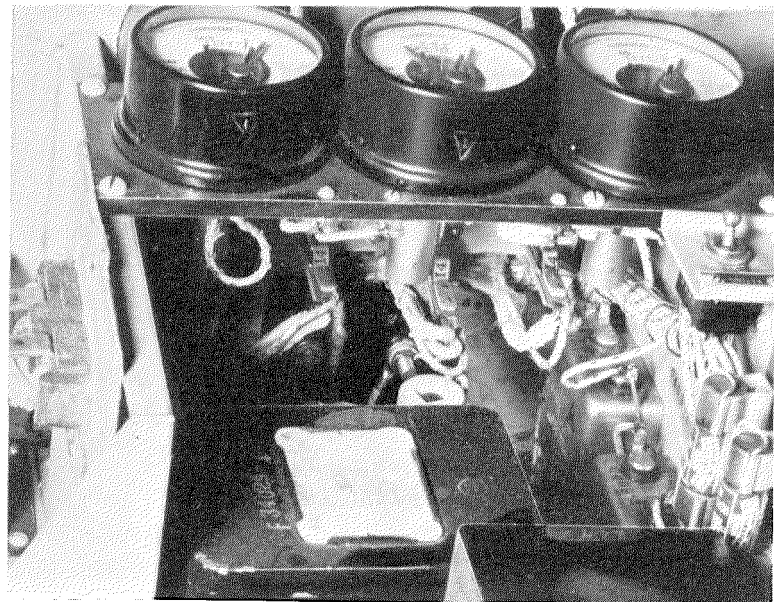

*Indicator box after service in tropics. Terminals are shorted, insulation broken down, and indicator pointers obstructed.*

Fungi require water, inorganic salts, and carbonaceous and nitrogenous foods, which may at times be derived from organic dust.

Electrically, fungi have the resistance characteristics of a weak salt solution. A growth across a high impedance point such as an antenna may effectively shunt that point with a resistance as low as 10 to 12 ohms.

### 5 Causes of Deterioration

Moisture has been recognized to be the most serious direct cause of trouble in the tropics. As previously outlined, moisture *per se* causes warping, swelling, delamination of parts, leakage paths, breakdown of insulation, and open circuits as a result of electrolytic corrosion. In addition, since fungi cannot grow without sufficient moisture, the elimination of moisture is of primary importance in retarding equipment deterioration.



*Under side of chassis of indicator box after tropical service. Fungi on insulating material lower insulation resistance and structurally destroy the material. Note corrosion on metal chassis.*

### 6 Early Tropicalization

The experience of oil companies in prewar exploration of humid and tropical areas demonstrated that most of the difficulties encountered can be eliminated by the choice of suitable materials, proper treatment of individual components, and adequate protection of circuits and components from dust and water. They also ascertained that the primary problem of tropicalization is the elimination of moisture. Considerable valuable data on the subject of insulation, sealing materials, and choice of components were compiled by these companies.

They were not, however, confronted with a problem of the urgency of that which faced the services at the start of hostilities. Remedial

measures had to be undertaken without delay. Emergency field measures initiated by the Armed Forces prevented a breakdown of operations until such time as a complete tropicalization program could be effected on the home front.

Military repair organizations, working under extremely difficult field conditions, were successful in providing adequate and correct protection. Thus equipment otherwise useless was speedily repaired and returned to combat troops.

It is obvious however that the application of field treatment involved the expenditure of innumerable man-hours by skilled personnel whose services were urgently needed for routine maintenance of equipment. Field operations were by their very nature inefficient. The apparatus had first to be disassembled, treated, and then reassembled, whereas the logical tropicalization point—the primary assembly line—would necessitate only one operation. Above all, the forces in the field were entitled to the best possible equipment that the home front was capable of providing and the problems of research, production, and special processing rightfully belonged to the original producers of the apparatus.

## 7 Government Procurement Measures

From the experience of those who had previously operated electrical apparatus in the tropics, from current field reports, and from laboratory developments, the fundamental principles of tropicalization were ascertained.

### 7.1 MOISTURE PROOFING

Since, as previously noted, moisture is necessary to the growth of fungi, the exclusion of moisture will prevent all fungous growth. It is, therefore, the primary enemy and its exclusion by hermetic sealing or repellant by coating is of first importance.

### 7.2 FUNGUS PROOFING

Surfaces which in themselves are moisture resistant may still support fungus growth and the ensuing structural breakdown may destroy water-repellant properties. In addition, the mere handling of moldy discolored equipment often has an adverse psychological effect on the morale of personnel. To inhibit such destructive fungous growths, protective coating materials, incorporating a fungicidal agent, are applied.

### 7.3 INSECT AND DUST PROOFING

It is important that apparatus be free from unsealed interior spaces in which minute insects and organic dust and debris may collect. In addition to the trouble these agents may cause by themselves, they promote the growth of fungi on otherwise fungus-free surfaces and cause etching of metals, optical glass, etc.

The U. S. Signal Corps, the Army Air Forces, the Bureau of Ships, and other agencies initiated an extensive program of research, education, and standardization. The laboratories at Fort Monmouth and Wright Field published tentative specification 71-2202-A (later supplemented by joint Army-Navy Specification JAN-T-152 and JAN-C-173) which pertains in large part to coating materials and outlines various requirements regarding drying time, viscosity, water-vapor diffusion constant, dielectric strength, resistance to thermal shock, non-toxicity, and resistance to fungi.

A series of lecture-conferences<sup>2</sup> was also held by the Signal Corps in November, 1944, at Philadelphia and at Chicago in December to disseminate information concerning the need for uniform methods and processes of tropicalizing equipment to lengthen its useful life in the field.

Overall tests were established to be applied to equipment before acceptance. These include the "rain forest" test wherein equipment is placed in a chamber in which the humidity is maintained at 90 to 95 percent and the temperature fluctuated between 20 to 66 degrees centigrade. The temperature cycle conforms proportionately to the day-and-night cycle in the tropics, each complete cycle covering 48 hours. Results obtained as to the moisture-resistant qualities of equipment closely paralleled reports from the field.

Completely assembled units and individual components were submitted to this process in two classes: those not sealed against immersion, which were required to pass a minimum of five cycles, and those sealed against immersion, which were required to pass a minimum of 15 cycles the last two of which were made with the cases removed. At the end of the specified number of cycles, the units were required to meet rigid standards of electrical and mechanical performance.

Fungus chambers were also utilized by the government testing laboratories. These consisted of large chambers kept at high humidity and approximately 30 degrees centigrade in which the interior air was saturated with fungus spores. Resistance to fungus growth of coatings, materials, and components was studied in these chambers.

Toxicity to human skin was also checked by applying the fungicides and coating materials to a small area of the skin of each of a large number of persons.

## 8 Industrial Program

To assist the already overburdened government research and testing laboratories, and to produce equipment which would pass the tests

<sup>2</sup> "Lectures on Tropicalization," compiled and edited by Inspection Manual Subsection, Quality Control Division, Fort Monmouth Signal Laboratory.

of service procurement agencies, industry turned its efforts to this problem. The field may be divided roughly into three parts.

### 8.1 REDESIGN OF COMPONENTS

This includes search for materials which are resistant to moisture and fungi, substitution of satisfactory resistant materials for vulnerable materials, and fundamental changes in design such as hermetic sealing and elimination of water traps.

### 8.2 COATING MATERIALS

Considerable progress has been made in the development of varnishes and lacquers which resist moisture and inhibit the growth of fungi and at the same time do not interfere with the electrical operation of the apparatus.

### 8.3 TESTING

Although it is not intended that any tests applied by industrial plants should supplant the official acceptance tests of the procurement agencies, considerable work has been done in devising tests for components and materials. This was for the purpose of determining the suitability of heretofore untried materials for tropical use.

## 9 F.T.R. Program

As a large producer of communications equipment and other apparatus for the Armed Forces, Federal Telephone and Radio Corporation, manufacturing associate of International Telephone and Telegraph Corporation, at an early date gave active attention to the problem of tropicalization.

A committee on tropicalization met at regular intervals to coordinate technique and exchange information. The program included laboratory testing and evaluatory studies of techniques as well as production-line treatment and inspection methods. To date more than a million pieces of equipment have been tropicalized for the Armed Forces.

## 9.1 LABORATORY

The primary purpose of laboratory work is the testing of materials, coatings, and fungicides to ascertain their resistant qualities. In addition to the conventional mechanical and electrical tests, water-vapor-transmission values and fungus-resistant qualities must be determined.

### 9.1.1 Water-Vapor Transmission

The permeability of an insulating film to water vapor is tested with a standard Thwing-Albert cup. A protective film of known thickness coated on a sample is used as the cup diaphragm. The rate of water-vapor transmission is determined from the loss of weight of water in the cup after a standard exposure to powerful desiccants.

### 9.1.2 Fungus Tests

Fungus-resistant qualities are determined by direct inoculation of the material to be tested with various species of fungi under conditions favorable to their growth. Since some fungicidal agents are selective in their inhibiting properties, several mixed species of fungi are generally used to insure adequate performance standards. The species utilized in Federal Telephone and Radio Laboratories are:

#### 9.1.2.1 *Aspergillus Flavus*

A yellow greenish mold having spiny septate conidiophores with smooth conidia. It is widely found on grains and in soil.

#### 9.1.2.2 *Aspergillus Niger*

Of the many species of *Aspergillus*, this is one of the most commonly occurring. Its colonies spread rapidly; the mycelium is white at first with areas of yellow and with stalks arising from the substratum several millimeters in length with globose heads. In its usual state the spores are black, imparting this color to the entire colony.

#### 9.1.2.3 *Penicillium Luteum*

This is also a very wide-spread species. It has a floccose aerial mycelium which is more or less yellow. Stalks arise several millimeters in length from the substratum with globose heads.

#### 9.1.2.4 *Chaetomium Globosum*

A cellulose-destroying fungus which is prevalent in soils. Its mycelium is originally white and fluffy, gradually darkening with formation of large, brownish-black spores.

#### 9.1.2.5 *Stemphylium Sp.*

Loose, wooly, aerial mycelia; brown-green colonies; large, multichambered spores occurring in chains. Cellulose-destroying.

#### 9.1.2.6 *Metarrhizium Sp.*

An active cellulose decomposer with a white, wooly, aerial mycelium and greenish-brown sporeheads.

#### 9.1.2.7 *Trichoderma Sp.*

Another fungus of the cellulose-destroying type. It has green-colored colonies with copious aerial mycelia and numerous small clusters of conidia attached to conidiophores.

#### 9.1.2.8 Culture Sources and Mediums

Pure cultures of these fungi can be obtained from the American Type Culture Collection maintained by Georgetown University School of Medicine in Washington, D. C., and U. S. Dept. of Agriculture. The desired cultures are kept in test tubes containing solutions of materials necessary to fungus growth.

There are numerous culture mediums for growing fungi, one of those widely utilized being

Czapek's solution agar, with the following formula:

Distilled Water	1 liter
Sodium Nitrate	3.0 grams
Di-potassium Phosphate	1.0 gram
Magnesium Sulphate	0.5 gram
Potassium Chloride	0.5 gram
Ferrous Sulphate	trace
Sucrose	30.0 grams
Agar Agar	15.0 grams

#### 9.1.2.9 Incubation

The materials to be tested are placed in Petri dishes or glass jars, with sufficient moisture, and are inoculated with spore solution by brushing, spraying, or similar application. A control of untreated material is utilized to check the vitality of the spore and the comparative effectiveness of fungicides. (Specification JAN-C-173 calls for the use of specifically designated types of aspergillus niger, aspergillus flavus, penicillium luteum, and trichoderma.) These dishes are then placed in a tightly closed chamber maintained at 28 degrees centigrade for approximately ten days. At the end of this period the extent of the zone of inhibition surrounding each specimen is measured. This bears a rough quantitative relationship to the activity and effectiveness of the fungicide with respect to the species being employed.

#### 9.1.2.10 Burial

This test is for fabrics, felt, insulating material, etc. The treated material, together with an untreated control, is buried in composted soil preferably at a pH of about 6.5. *Chaetomium Globosum*, a rot-producing microorganism which attacks cellulosic materials is the species inoculated into the soil and test samples. The soil-suspension procedure is used primarily in the case of textiles, such as for sand-bags, which are intended to come in direct contact with the soil. Results obtained with this test are not always similar to those obtained with incubation techniques.

To ascertain the solubility of the fungicide and its resistance to weathering, the material is leached before burial. Fabrics which may be laundered in service are steam treated in the

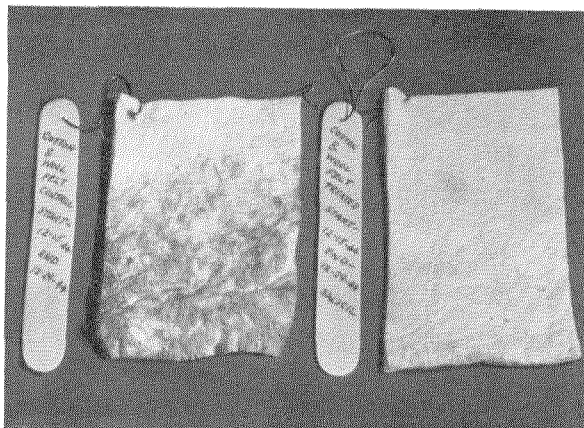

*Fabric after soil burial test.*

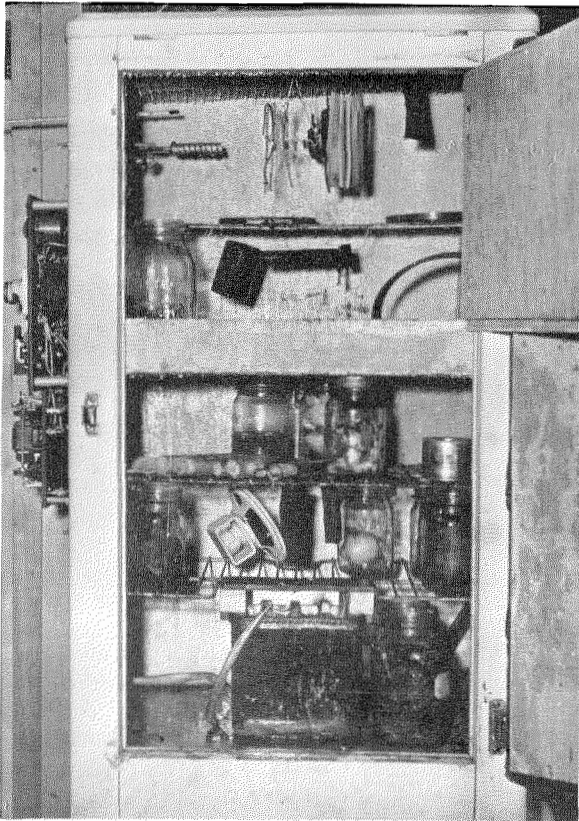

*Incubation chamber with humidity kept high by water tank and heater, used for testing equipment in the Radio Products Division of Federal at Newark, New Jersey.*

laboratory at 121 degrees centigrade under 15 pounds pressure for one hour prior to inoculation. Tensile-strength tests are run after the burial period to determine the extent to which the material has been weakened.

## 9.2 PRODUCTION

### 9.2.1 Material Selection

Material resistant to the effects of fungi and moisture, as determined by field reports and laboratory tests, should be used wherever possible. In general, although there are numerous exceptions, inorganic materials are more likely to be resistant than organic.

Recommended materials at the present time include ceramics having a glaze finish when used for mechanical purposes and ceramic insulators of steatite, porcelain, glass, and glass-bonded

mica. For meter cases, asbestos- and mica-filled materials have been found to be more resistant to fungus growth than wood-flour-filled materials and those with long cellulosic fibers. Plastic insulating sleeving of the polyvinyl chloride type has shown superior field performance over the conventional fabric and cellulose acetate sleeving.

A prime factor in the choice of metals used is the structural design of the equipment. Corrosion is promoted if two metals, widely spaced on the electromotive series, are in contact.

Many materials ordinarily used in radio components were found unsatisfactory under tropical conditions. Difficulty was encountered with compression-type capacitors, laminated tube sockets and toggle switches, and cellulosic materials in general.

Ropes, jute, twine, and thread are treated during manufacture with fungicides dissolved in



*Incubation chamber containing Petri dishes and jars for testing materials in Federal Telecommunication Laboratories at New York.*

organic solvents and, afterwards or simultaneously, are treated with water-repellent agents. Wood and plywood are protected against attack by means of rot-proofing sealers.

The above material selections, chosen for illustration, are only a few of those recommended. The number of approved materials is constantly being added to as increased knowledge based on field experience and research is gained.

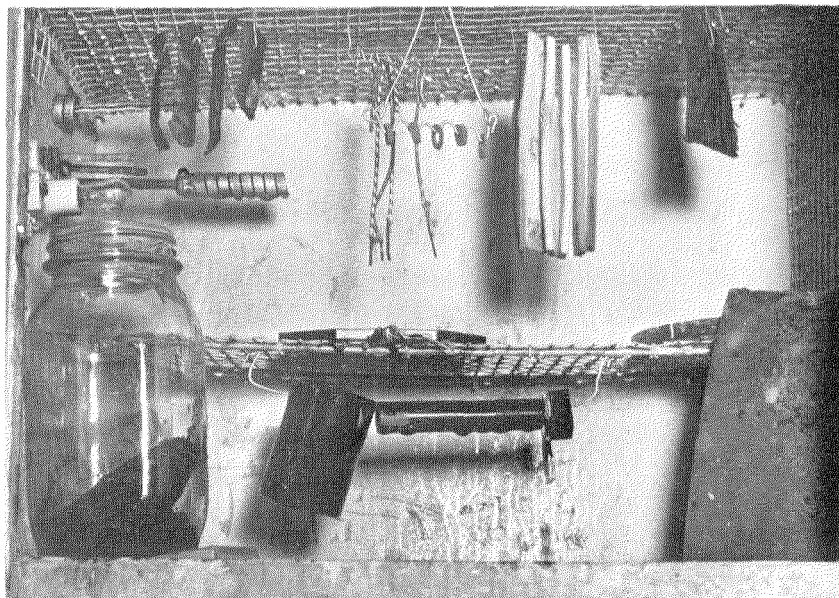

*Portion of interior of incubator, showing materials under test suspended therein.*

### 9.2.2 Hermetic Seal

Hermetic sealing, where design considerations and flexibility requirements do not render it impossible, is a highly satisfactory means of excluding moisture from individual components and even complete units. Glass-to-metal and ceramic-to-metal seals have recently been considerably improved.

The hermetic sealing of transformers is especially important and has found wide application. As key components in communications equipment, their failure is a serious matter. Delicate instruments, particularly meters, are now manufactured featuring completely sealed outer cases.

### 9.2.3 Protective Coating

Specification 71-2202-A, supplemented by JAN-T-152 and JAN-C-173, describes materials for coating equipment such as lacquers or varnishes. The coating film must be as nonporous as possible and must be uniformly applied and free from bubbles and air holes. The particular type of coating material depends on the nature of the apparatus. The exact point in the production process at which the coating is applied is determined by the particular equipment and the method of manufacture. Many devices can be satisfactorily treated when they are completely

assembled while in other instances it may be necessary to treat the subassemblies separately, subsequently coating the various interconnecting wiring and soldered connections. All circuit elements are coated as well as all unpainted metallic surfaces.

The coating material is generally applied by the spray method. The application technique used, however, differs from that of ordinary spray-painting. Very low air pressure is employed to prevent too fine a degree of atomization, to reduce back pressure in crevices, and to produce a wet coat, evenly covering and sealing the equipment surfaces. Other methods of application are brushing by hand and, if suitable, immersion into the material.

Those components or portions of apparatus which, if coated with lacquer or varnish, would impair the proper electrical or mechanical functioning of the equipment, must be suitably shielded from the spray by masks.

It is important to avoid breaks, fissures, or voids in the protective coating. For quick and efficient inspection, ultra-violet light is used with a black filter. A small amount of fluorescent dye is added to the coating material and, under the ultra-violet light, uncoated areas appear dark and are readily discernible.

#### 9.2.4 Fungicides

The coating materials in use are organic, unpigmented systems which form hard, glossy, non-wetting surfaces when dry. As previously indicated, fungous attack will deteriorate originally perfect surfaces particularly under severe tropical conditions. To inhibit this fungous growth on coated surfaces, a fungicide is incorporated into the varnishes and lacquers.

There are two basic types of fungicidal surface-coating materials which meet the requirements of specifications 71-2202-A, JAN-T-152, and JAN-C-173. These are lacquers and varnishes, the particular application determining which is the more suitable. In general the lacquers are quicker drying, while varnishes have better adhesion to phenolic materials and better resistance to water and elevated temperatures.

Three classes of fungicidal agents have been found to be satisfactory. Of the first group, the phenyl mercurials, the salicylate, and the stearate are the most widely used. Of the chlorinated phenols, the pentachlorophenol and tetrachlorophenol have been found most suitable. The third type is salicylanilide. These three types have been developed and used by various manufacturers in several forms in varnishes, paints, waxes, and lacquers. When exposed to high temperatures, some types of fungicides volatilize and become ineffective. Phenyl mercuric salicylate and stearate are the most stable under such conditions. The mercurials, however, are not recommended on selenium rectifiers or other electrical components adversely affected by mercury vapors.

#### 9.2.5 Packing

Because of the general necessity of storing shipped goods in warm dark places, such as the humid holds of ships, as much as 90 percent of shipped equipment in some cases were rendered useless before being delivered for service. At present, careful packing in rot-proof containers and the inclusion of silica gel desiccants with the equipment to maintain a low moisture content have whittled shipping losses to nearly negligible proportions.

#### 9.2.6 Shop Testing

The fungus- and moisture-resistant quality of materials, fungicides, and coatings applied to

equipment is determined by placing the substance in an environment closely simulating or even exaggerating tropical conditions.

### 10 Tropicalization in the Future

American industry, in cooperation with Government agencies, has made valuable strides toward designing and producing tropicalized electrical apparatus and communications equipment. Although to a large extent the demands of the Armed Forces have been met, a final solution has not yet been achieved. Continued endeavor and progress in this field is still needed.

With the arrival of peace, the problems solved and the techniques developed continue to be of considerable importance. An immediate benefit from tropicalization is the availability of suitable equipment to oil and other exploration groups operating in humid areas.

More far-reaching, however, are the possibilities for the hitherto undeveloped areas of the tropics which war-stimulated developments in air transportation will make more accessible. One of the reasons for the "backwardness" of tropical territories has been that much equipment and machinery was not usable because of climatic conditions. In the postwar era, industry will be able, to an extent not previously attained, to produce both capital equipment and consumers' goods capable of providing satisfactory service in tropical lands, thereby assisting in raising the standard of living. The beneficial economic effect of such a development may be equivalent to the opening of new frontiers.

### 11 Acknowledgment

Grateful acknowledgment is made of the information obtained from the Armed Forces, both through the conferences sponsored by them and from their various specifications on tropicalization. The work of the Humble Oil and Refining Company was an important and early contribution to the subject. Acknowledgment is also made of the contributions to the preparation of this paper by Gaillard Hunt and F. J. Morrow of Federal Telephone and Radio Corporation, and J. K. Whitteker, A. Glueck, and R. E. Houston of Federal Telecommunication Laboratories, Inc.



# Twenty Years of Telephony in Spain

By O. C. BAGWELL and J. J. PARSONS

*International Telephone and Telegraph Corporation, New York, New York*

FOLLOWING careful study of the possibilities of installing a modern telephone system throughout Spain, the International Telephone and Telegraph Corporation started negotiations in April of 1924 for an exclusive contract of concession to be granted the *Compañía Telefónica Nacional de España*, a Spanish company organized and controlled by the I. T. & T. These negotiations resulted in the signing of a contract on August 29, 1924, between the Spanish Government and the CTNE for furnishing a homogeneous and comprehensive telephone system throughout Spain, excepting local service in the province of Guipuzcoa.

The concession provided that the Spanish Government would have the right, after the expiration of twenty years, to purchase the telephone properties under a predetermined formula for ascertaining the purchase price, and since the Spanish Government has now completed negotiations with I. T. & T. to purchase its stock interest in CTNE, in lieu of the purchase under the contract, it is timely to review the construction and development of this telephone system for the last twenty years under the aegis of I. T. & T.

The then-existing system was composed of various plants owned by the State, municipalities, and numerous private companies, large and small. The main toll lines connected only the large cities with a network which was both deficient and inadequate. It was not possible to talk from one boundary of the country to a point on the opposite boundary. No repeaters were used and such long-distance service as was rendered was of very poor quality and was limited mostly to calls to and from Madrid.

Local telephone service, even in the large cities such as Madrid, was unsatisfactory. While certain areas had common-battery service, the majority were still on a magneto basis, and all of the switchboards were of antiquated types and of inadequate capacity. Fig. 1 contrasts the typical urban switchboards of this era with the modern units which replaced them. Local dis-

tribution consisted of overhead cables covered with a fabric in place of lead, feeding large towers and roof-top fixtures from which open wire lines were strung to the subscriber's premises. Illustrations of these structures are shown in Figs. 2 and 3 and of a typical new cable entrance in Fig. 4.

The existing system was so deficient that available data on traffic and commercial possibilities could not be used for calculating future growth. However, it was considered that the financial returns would justify the investment required to build a modern telephone system to provide an adequate service which would be of great benefit to the country.

## **1. Reconstruction and Expansion Program**

While negotiations for the concession were in progress, plans were formulated for the reconstruction of the telephone system. As soon as the contract was signed, a group of engineers and technicians were sent to Spain to initiate these plans, supervise their execution, and train the necessary large staff of Spanish personnel.

As a first step in providing for adequate local service, suitable building sites for central offices were purchased in Madrid, Barcelona, and other large cities and towns. Construction of buildings was begun as soon as final plans could be prepared and contracts let. About this time, the I. T. & T. purchased the International Western Electric factories in the foreign field and changed the name of the company to International Standard Electric Corporation. It was decided to standardize on the well-known Rotary Automatic System, which had been developed by the International Standard Electric engineers, for all the principal local service areas. Initial orders for 7-A-1 Rotary equipment were placed with the Bell Telephone Manufacturing Company, Antwerp, an International Standard Electric associated company, for the central-office exchanges in Madrid, Barcelona, Valencia, Sevilla, Bilbao, Santander, and other important cities.

Such was the speed with which this program was prosecuted that automatic service was inaugurated in Santander in the summer of 1926 and in Madrid in December of the same year. Conversion of the service in other cities followed in rapid succession.

Concurrently with the reconstruction of the local plants, a vast program of toll-line construction and rehabilitation was undertaken. This work advanced so rapidly that at the inauguration of automatic service in Madrid in December, 1926, it was possible to stage a toll demonstration in which stations in principal cities throughout the country were interconnected with each other and with Madrid over a built-up circuit having a cumulative length of 3,800 kilometers.

In the layout of a toll network, Madrid is not only the capital but is almost the exact geographical center of the country, making an ideal point from which to distribute toll traffic. The toll operating room in Madrid is shown in Fig. 5.

The coal mining industry lies to the northwest, centering around the city of Leon; heavy industries, such as steel mills, are located at Bilbao, some 250 kilometers east of Leon. The textile industries are located in and around Barcelona. Copper mines are in the southwest near the city of Huelva. Plains to the north of Madrid are devoted almost exclusively to the raising of wheat. The south central area is the great olive-producing section of the country; dates and hemp are raised around Murcia in the southeast with the coastal region around Valencia devoted to

rice and oranges. As Spain is almost surrounded by water, there are many excellent ports and the fishing industry is active at every part of the seacoast.

A map of Spain, Fig. 6, shows the network of main toll lines and indicates those sections in which cable has been installed. Carrier systems are used extensively to provide the longer circuits, with 24 three-channel carrier terminals in Madrid. The map also shows the cities having automatic local service. To indicate the extent of the network, the distance from Madrid to Zaragoza can be taken as being approximately 300 kilometers.

The cable network was originally designed to extend from Madrid to Zaragoza and from there to Barcelona and to Bilbao and France. The sections represented in the map cover about 440 kilometers of buried toll cable. This cable is made up of 16-gauge quads for 2-wire circuits and 19-gauge quads for 4-wire operation. The Barcelona-Valls section is a full-size cable with 58 quads of 16-gauge and 40 quads of 19-gauge conductors. The section between Zaragoza and the French border is a  $\frac{2}{3}$ -full-size cable and is spliced to the French cable extending direct to Paris.

It would appear logical that the cable network should have started at Madrid, but when the cable program was initiated the section between Zaragoza and Tolosa consisted of a 6-arm toll lead while the Zaragoza-Madrid section utilized only 3 crossarms. The reason for

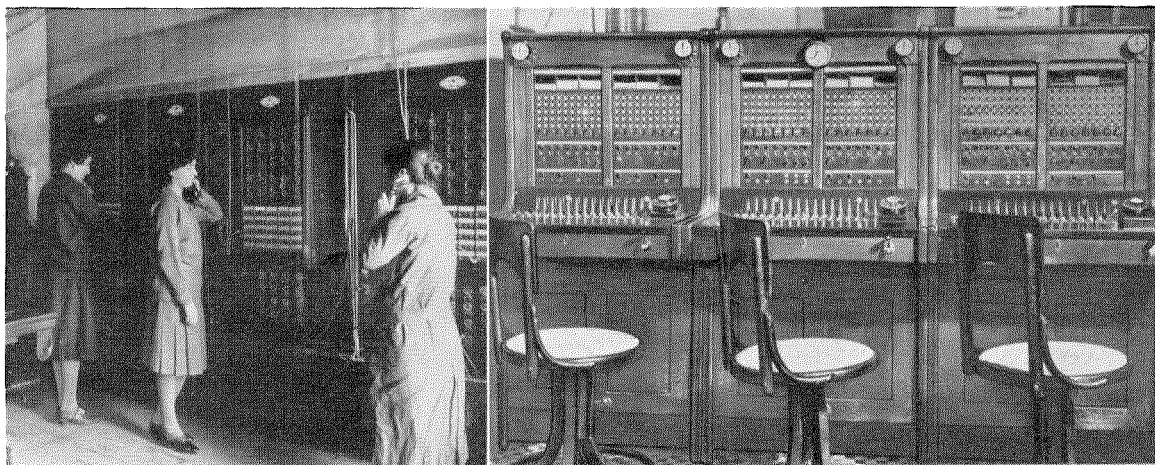

*Fig. 1—In 1924, the urban switchboards at the left required 3 operators for each 100 subscribers. One of the modern boards at the right, under the control of a single operator, serves that number of subscribers.*

this is the close community of interest in the Bilbao-Zaragoza area which requires a large number of circuits for intercity service. Also a large number of circuits were operated between Bilbao and Barcelona, the two principal industrial cities and the largest ports.

Barcelona is connected with Palma, Majorca Island, by ultra-short-wave radio designed for 9 channels, ultimately, and with 2 channels equipped initially. Palma in turn is connected to Ibiza and Minorca by ultra-short-wave radio.

Algeciras is connected with Ceuta on the African continent by submarine cable and by ultra-short-wave radio with land lines to Tetuan and other Moroccan points except Melilla, which is in direct communication with Malaga by an ultra-short-wave radio link.

Not shown on the map are the Canary Islands which are connected direct to Madrid by short-wave radio. The two largest islands of the group, Tenerife and Gran Canaria, are interconnected by submarine cable equipped for carrier operation ultimately. The smaller islands have recently been interconnected by radio.

The growth in total length of toll circuits, and the proportion of physical, phantom, carrier, cable, and radio are shown in Fig. 7. The chart

covers only the period to 1936 when the Spanish Civil War started. Very little change has occurred since then because of unsettled conditions.

## 2. Growth of Service

Within five years after the signing of the contract, automatic equipment had been installed in 27 offices giving automatic service to 18 cities. In 1943 there were 57 automatic offices in 47 cities.

Only 738 cities and towns had toll service in 1924. There are now 3,605 Spanish cities and towns with toll service not only to each other but to the telephone network of the world.

In 1924 there were about 80,000 telephones in the territory now served by the CTNE. At the end of 1944 there were 406,513 telephones, 72 percent of which were automatic.

Long-distance toll calls, in the first year of operation under the CTNE, totalled 3,169,883. In 1944, 41,623,586 calls were handled within Spain in addition to 212,755 calls to foreign countries although the traffic was naturally curtailed because of war restrictions.

At the time the contract was made, there were 40,145 kilometers of toll circuits in service, while in 1944 there were 137,976 kilometers of

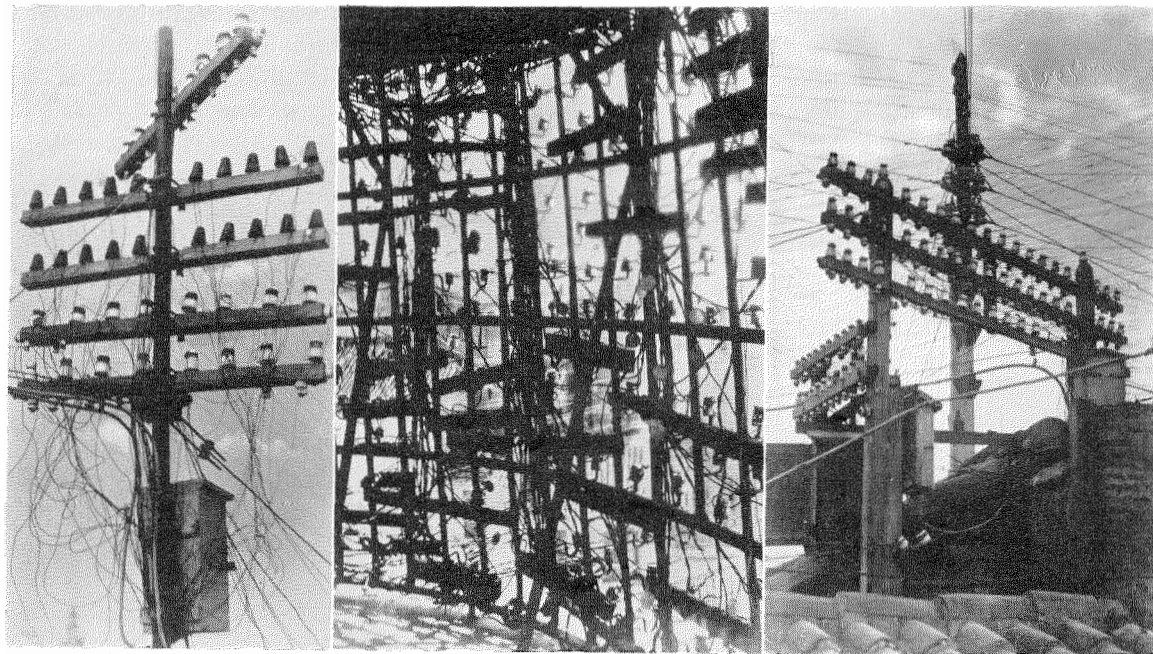
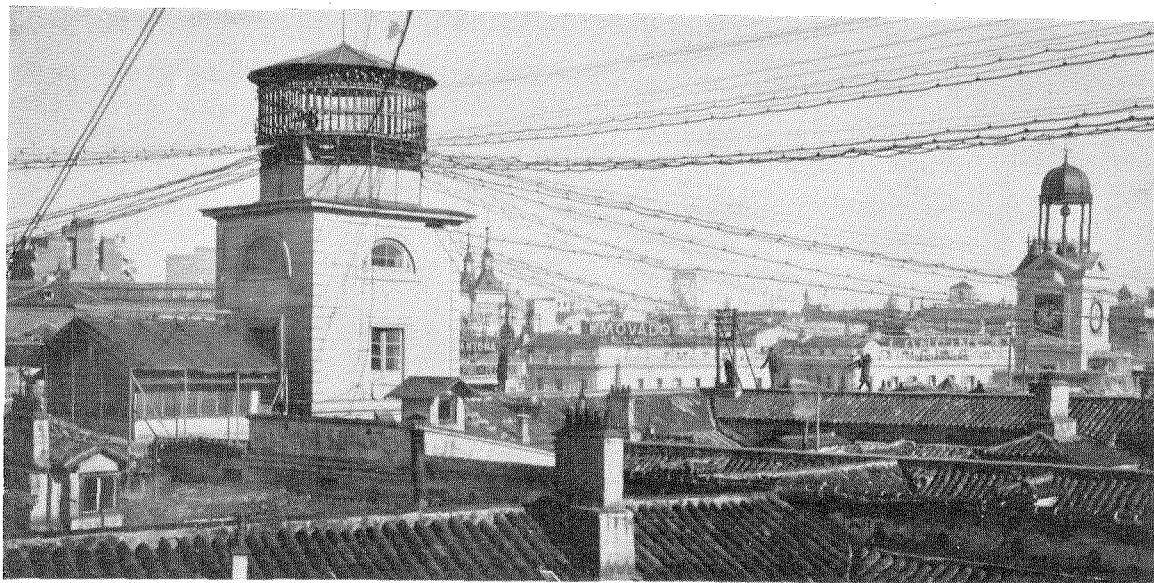

Fig. 2—Outside plant of the type utilized in 1924.



*Fig. 3—Cable tower in the Puerta del Sol, Madrid, 1924.*

open wire circuits. Through the use of toll cables, phantom circuits, carrier, and radio, a total of 387,699 kilometers of talking channel was available in 1944.

The growth of stations and long-distance traffic is shown in Fig. 8. The years 1936 to 1939, inclusive, are omitted as accurate data are not available for this period.

In 1924, international telephone service was available only to France and Switzerland through a Madrid-Paris circuit. In 1928, service was opened with the United States, Canada, and Cuba, via direct circuits from Madrid to London and thence to the U. S. A. by radio. In 1929, the Pozuelo del Rey radio transmitting station was opened with direct service to Argentina and by subfluvial cable to Uruguay. By 1936, service had been established to 78 foreign countries.

Development of the Spanish telephone system was interrupted in 1936 by the outbreak of the Civil War. The telephone company had hardly recovered from the effects of that conflict when World War II started. The consequent restrictions on materials have not permitted as extensive development during the war period as is considered desirable to meet the continuously growing demand for telephone service, both long distance and local. To meet this need, plans have been formulated for furnishing equipment and outside plant for 136,500 new subscribers and

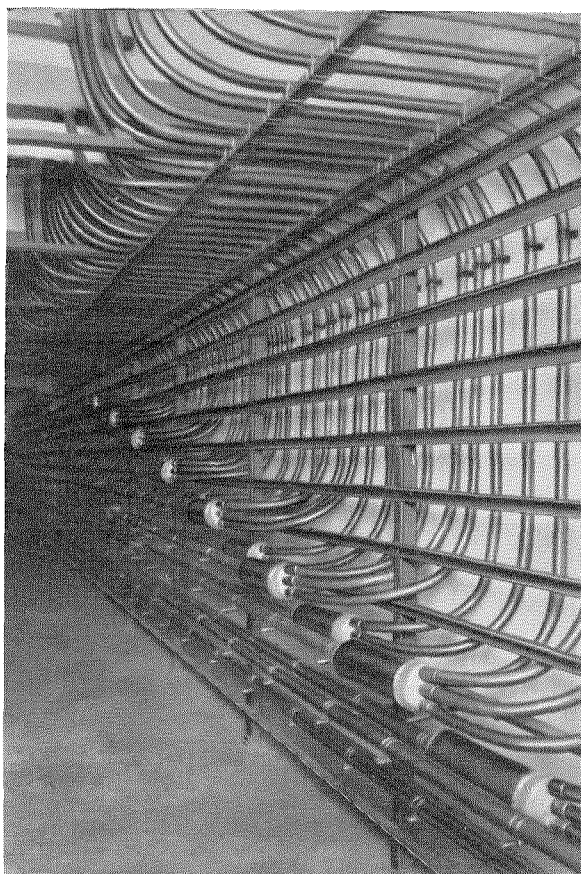

*Fig. 4—Modern installation of underground entrance cables of the Jordan central office, Madrid.*

for providing 224,000 kilometers of toll circuit, the latter to consist of cable and the maximum use of multichannel carrier telephone systems.

### 3. Personnel Training

One of the first steps taken by the company after obtaining the concession was the establishment of schools for training local personnel in the various phases of telephone work, a program which has been continued and amplified with highly gratifying results. Initially, these were purely practical schools teaching workmen how to do specific kinds of work. They were gradually developed over the years to include theoretical training in subjects such as geometry, trigonometry, physics, electricity, automatic telephony, plant-construction methods, and bookkeeping. The schools were designed to accommodate 200 students at a time. Terms lasted from two to six months depending on the subjects being taught. Students were selected by competitive examinations which in certain cases were open also to nonemployees. Salaries were paid to the students while learning and, in the case of those from out of town, certain living expenses were defrayed. Up to 1944, about 5,000 students had passed through the various courses at the school; the majority of them are today employed in some department of the CTNE.

As a result of this policy, the company is now staffed almost exclusively by Spanish nationals, who have been prepared in these schools for positions requiring the highest degree of specialized knowledge and training.

### 4. Spanish Factories

Although the initial demands compelled immediate importation of telephone equipment, two factories were planned, one for telephone apparatus and one for cable, to be operated by a newly organized company of the I. T. & T. system, Standard Electrica, S. A. For engineering personnel, promising students were selected from the famous universities in Madrid, Barcelona, and other cities of Spain. Many were sent abroad to study in the London, Paris, and Antwerp laboratories and factories of the I. T. & T. System.

Santander was chosen as the site for a cable plant. Aided by the manufacturing departments of associate companies in London, Paris, and Antwerp, this factory, soon after its inauguration in August, 1927, produced its first lead-covered cable, a 1212-pair paper-insulated subscribers' cable. In 1930 and 1931, the extensive toll cable between Zaragoza and San Sebastian was manufactured completely at Santander.

It was decided in 1925 to build the telephone factory in Madrid, where the engineering and technical services were located. While this factory was being constructed, a small staff, some machines, and two buildings in Madrid were obtained from a manufacturer of household electrical appliances, and production was started on simple telephone parts. Here were assembled and tested the first telephone repeaters to be installed in Spain to complete the initial long-distance circuit from Madrid to Ceuta on the north coast of Africa.

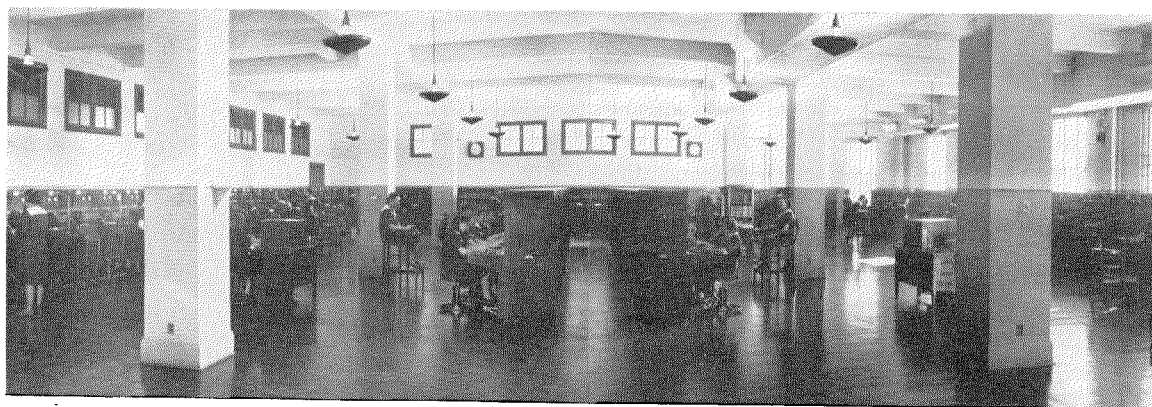

Fig. 5—Madrid toll operating room.

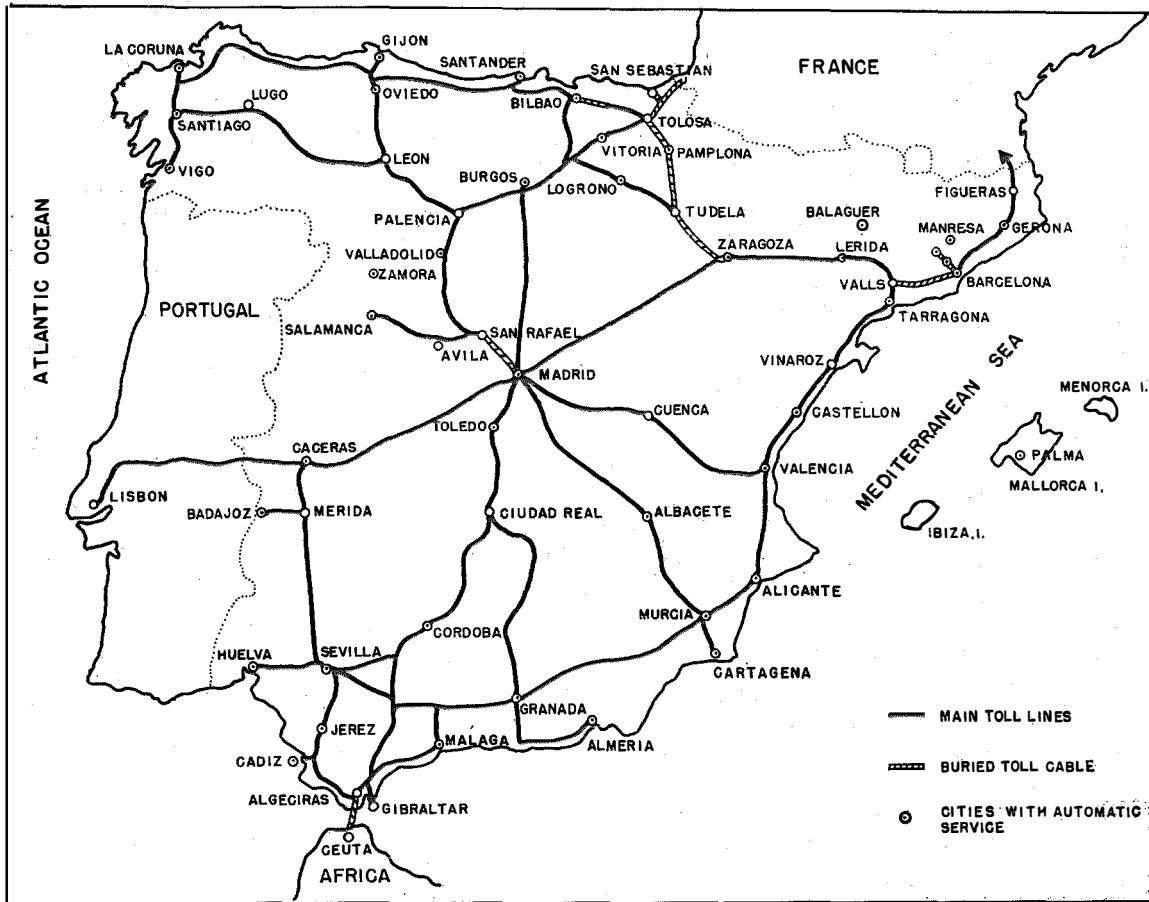

Fig. 6—Main toll network of Spain. Cities having fully automatic local service are indicated.

By February, 1928, when the factory shown in Fig. 9 was inaugurated, complete subscribers' sets were being manufactured in temporary quarters and the assembly of many items of equipment was well under way. Soon thereafter, a full-fledged engineering department was engaged in designing toll and central-office equipment. Even before the factory could produce all of the apparatus for those complex systems, parts were ordered from other I. T. & T. plants and the engineering and manufacturing was controlled from Madrid. Special radio apparatus for the Spanish army and navy was also being developed. A sales and engineering office was handling industrial and special communication installations.

After 1929, with these two factories, Standard Electrica, S. A., became the principal manufacturer for Compañia Telefónica Nacional de España. During the years 1934-35, Standard

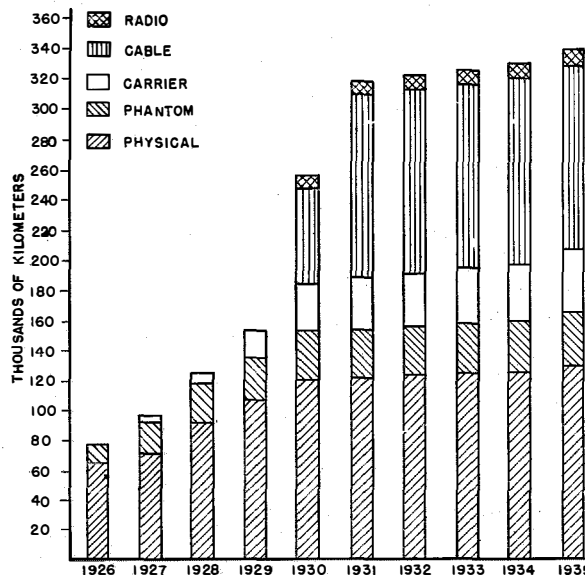

Fig. 7—Total length of toll circuits from 1926 through 1935, when the Civil War started. Unsettled conditions have prevented substantial expansion since then.

produced an average of approximately 10,000 lines each of 7-A and 7-B Rotary equipment. The program at that time contemplated the conversion of approximately 8 to 10 provincial capitals per year for which the complete automatic and toll equipment was engineered and manufactured locally.

At the present time, the Madrid factory, which continues under the control of the International Standard Electric Corporation, a subsidiary of I. T. & T., has built or has under construction approximately 400,000 square feet of manufacturing floor space and has a staff of about 2,200 trained employees. It has become a well-established national industry which, in addition to producing communications equipment for the telephone company and many branches of the Spanish Government, is Spain's principal producer of precision apparatus of all types.

### 5. *Résumé*

In 1924, the Compañía Telefónica Nacional de España was formed by I. T. & T. to receive from the Spanish Government an exclusive con-

tract to provide telephone service in Spain. Through the installation of automatic Rotary equipment for local and toll switching services, a reliable, rapid, and efficient system has been provided.

Careful planning and design; the installation of adequate equipment, properly maintained; and the effective handling of engineering, traffic, and commercial problems have in the twenty years of this system, resulted in a telephone service to the public second to no other and established a most successful company from all viewpoints.

This modern telephone system is now in the control of the Spanish Government. It should perhaps be added that the Spanish Government has indicated its intentions of maintaining the CTNE as a private enterprise by distribution of the shares acquired from I. T. & T. to the Spanish public, in which case, the Government has also indicated its desire that I. T. & T. reacquire a small block of shares and enter into a technical and advisory contract to assist the CTNE in its further development and operation.

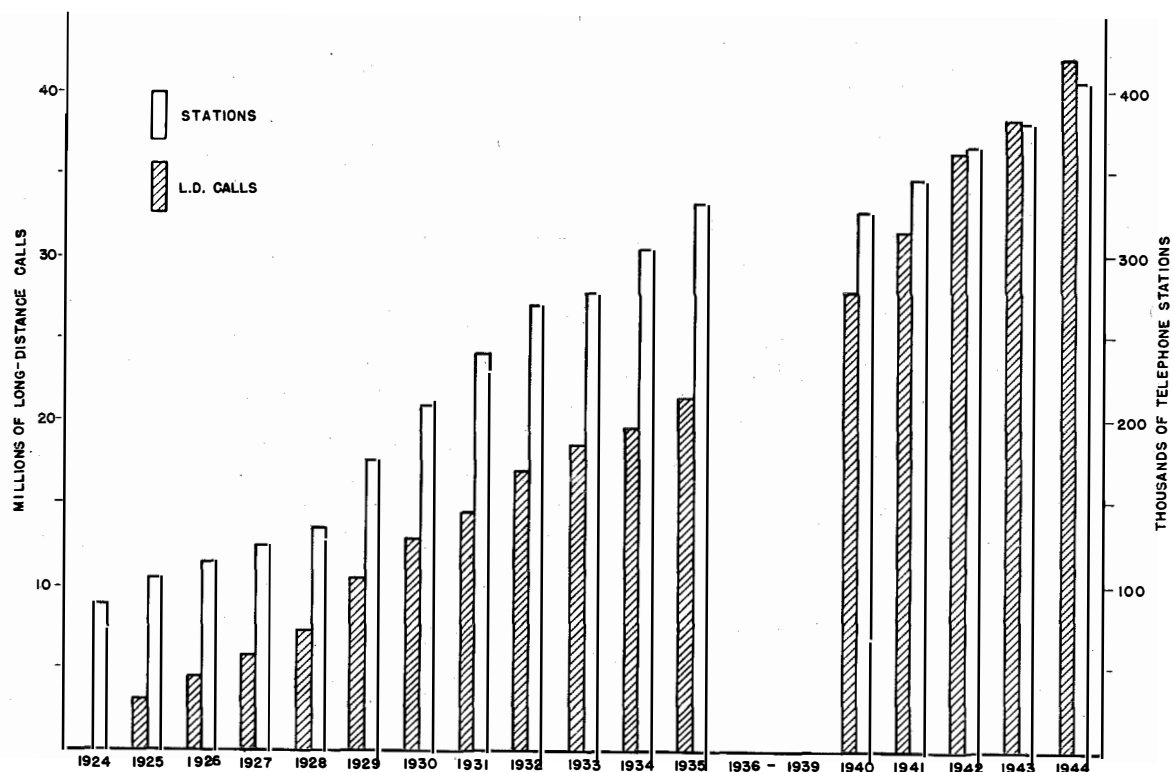

Fig. 8—Growth of subscribers' stations and long-distance calls. Data for the period of the Civil War are not available.



Fig. 9—The Madrid factory of Standard Electrica, S. A., one of the two I.T.&T. plants in Spain.

The use of associate-company laboratories and factories in training engineering personnel, the availability of their experienced staffs in getting Spanish factories in operation, together with the establishment of a trade-type school in Madrid, reduced greatly the time that would ordinarily have been required in building and manning this organization with Spanish nationals.

Since the modernization program was initiated, the number of subscribers has increased over five times. Moreover, the length of toll talking channels has been extended more than ninefold, and the volume of long-distance traffic has multiplied about thirteen times.

#### **Electrical Communication References**

1. "New Madrid Telephone Building," v. 5, n. 3, 1927.
2. D. B. Baker, "Train Dispatching in Spain," v. 6, n. 2, 1927.
3. K. McKim, "Providing Madrid with Automatic Telephone Service," v. 6, n. 3, 1928.
4. L. G. Freeth, "Madrid-London-Paris Telephone Service," v. 8, n. 3, 1930.
5. G. H. Nash, "Introduction to Special Issue on Madrid-Buenos Aires Shortwave Radiotelephone Link," v. 8, n. 4, 1930.
6. G. H. Gray and N. K. Fairbank, "Madrid-Buenos Aires Radio Link and Its Wire Connections," v. 8, n. 4, 1930.
7. F. T. Caldwell, "Inauguration of Madrid-Buenos Aires Radiotelephone Link," v. 8, n. 4, 1930.
8. O. C. Bagwell and J. R. Gopegui, "Carrier Systems in Spain," v. 9, n. 1, 1930.
9. F. T. Caldwell, B. A. Turkhud, and J. J. Parsons, "The New Telephone Plant in Barcelona, Spain," v. 9, n. 2, 1930.
10. F. T. Caldwell, "The Tenerife-Gran Canaria and Algeciras-Ceuta Cable Systems," v. 9, n. 4, 1931.
11. K. E. Latimer and J. R. Vezey, "Tenerife-Gran Canaria and Algeciras-Ceuta Submarine Cables," v. 9, n. 4, 1931.
12. W. H. Warren and J. J. Parsons, "New Madrid Toll Board," v. 9, n. 4, 1931.
13. G. N. Saurwein and M. Marin, "Ten Years' Experience in Maintenance of Rotary Automatic Equipment in Spain," v. 15, n. 1, 1936.



# Standard Telephones & Cables Pty. Ltd., Australia— 50th Anniversary

By J. CLARKE

*Commercial Director, Standard Telephones & Cables Pty. Ltd., Sydney, Australia*

THE foundation of Standard Telephones & Cables Pty. Ltd. was laid 50 years ago, when in 1895—six years before the federation of the Australian colonies into the Commonwealth of Australia—Mr. S. Kingsbury, representing the Western Electric Company, arrived in Australia from London and opened an office in Vickery Chambers, Pitt Street, Sydney.

Since that time S.T.C., as the company is popularly known in engineering circles and to the general public throughout Australasia, has played a highly important part in the development of the communication services of the Commonwealth of Australia and of the Dominion of New Zealand in both peace and war.

The Company became Australian in character in 1912, in which year the Western Electric Company (Australia) Ltd. of Sydney was formed with Mr. R. B. Hungerford as Managing Director. Mr. Hungerford arrived in Australia in 1903 as Manager of the Australian Branch of the Western Electric Company of London. The thirty years during which he was in control of Australian activities, 1903 to 1932, were an epoch in the Company's history. Much pioneering was done in the field of electrical communications in Australia and New Zealand during that period, and the foundations were laid for the unique position which the Company enjoys today as supplier and manufacturer of much of the equipment which constitutes the backbone of the electrical and radio communication systems of both countries.

It was under the direction of Mr. Hungerford that the Company supplied the equipment for the following installations which were of notable importance in the evolution of electrical communication in Australia and New Zealand, viz., the first rotary automatic telephone exchanges; first carrier-wave telephone and telegraph systems; first public-address system; first hospital radio receiving system; first regional broadcast-

ing stations; the Adelaide-to-Perth carrier telephone equipment completing the trunk line from Geraldton, West Australia to Cloncurry, Queensland, a distance of approximately 6,000 miles and one of the longest telephone trunk lines in the world; New Zealand's first automatic telephone exchanges and pioneer broadcasting stations.

In 1925, the Company became associated with the International Telephone & Telegraph Corporation and its name was changed from Western Electric Company (Australia) Ltd. to Standard Telephones & Cables (Australasia) Limited. The Company was authorised to hire premises suitable for manufacture in Australia in 1926 and the first telephones and repeater coils were made in the Sydney factory at Chippendale in 1927, in which year sales reached record figures, which were not surpassed until 1937.

Mr. Hungerford died in 1932 and was succeeded by Mr. H. C. Trenam, who joined the London organisation in 1906. Mr. Trenam arrived in Australia to take up his appointment as Managing Director of the Australasian organisation in 1933. At the time of his transfer, Mr. Trenam was Managing Director of Creed & Company, Ltd., London, and a Director of Standard Telephones and Cables Ltd., London. In 1944, Mr. Trenam was appointed a Vice President of International Standard Electric Corporation.

Under his able leadership, the Company has made spectacular progress. By 1935, the Chippendale factory was unable to cope with the Company's rapidly expanding business. The desirability of the Company having its own premises became apparent. A building site was acquired in Botany Road, Alexandria, a suburb of Sydney, and up-to-date premises were erected with a floor space of 20,000 square feet. Manufacturing commenced in 1936. But so rapidly did the Company's business expand that building extensions became necessary in 1938, and a two-

storey building was added. This was increased to four stories in 1942. The demand for local manufacture, however, continued to outstrip production. Additional land was acquired and another four-storey building was erected in 1942, only to be followed by still another four-storey building which was completed in 1944. More land has since been acquired on which a two-storey building will be completed in 1945.

Under Mr. Trenam's direction, sales have reached an all-time record. Business has expanded enormously and the Company's premises have increased in area from 20,000 square feet of floor space in 1936 to over 200,000 square feet. An imposing landmark in a district which has been referred to as the "Birmingham of Australia," this modern factory is a monument to Mr. Trenam's leadership and to the close teamwork of his staff.

For security reasons, National regulations preclude details being given of the Company's efforts in the present war. Much of the equipment it has designed and manufactured has been of vital importance in achieving victory in some of those historic Allied campaigns in the South West Pacific. Some of its achievements compare in size and importance with any of their kind in other parts of the world. A notable example is the equipment which the Company manufactured in 1938 for a Royal Australian Naval Station which has a power of 200 kilowatts.

Standard Telephones & Cables Pty. Ltd. has a highly skilled staff of technical, manufacturing, and commercial personnel, engaged in the manufacture and supply of many ancillary lines such, for example, as selenium rectifiers, an important product in a specialised field which the Company has pioneered in Australia. Radio broadcast receivers are another specialty of the Company. Many thousands of Australian and New Zealand homes are equipped with S.T.C. radio receivers. The Company's slogan "For tone it stands alone" is one of the best known in Australia and New Zealand.

#### 1895-1945

- 1895 Sydney office of Western Electric Company opened by Mr. S. Kingsbury.
- 1903 Mr. R. B. Hungerford placed in charge of Sydney office.
- 1912 Western Electric Company (Australia) Ltd. formed with Mr. Hungerford as Managing Director.
- 1913 New Zealand Government placed order with Company for first automatic telephone exchanges.
- 1914 First train-control telephone system in Australia supplied to New South Wales Government Railways.
- 1922 Contract obtained from Postmaster General's Department for 313 miles of lead-covered cable.

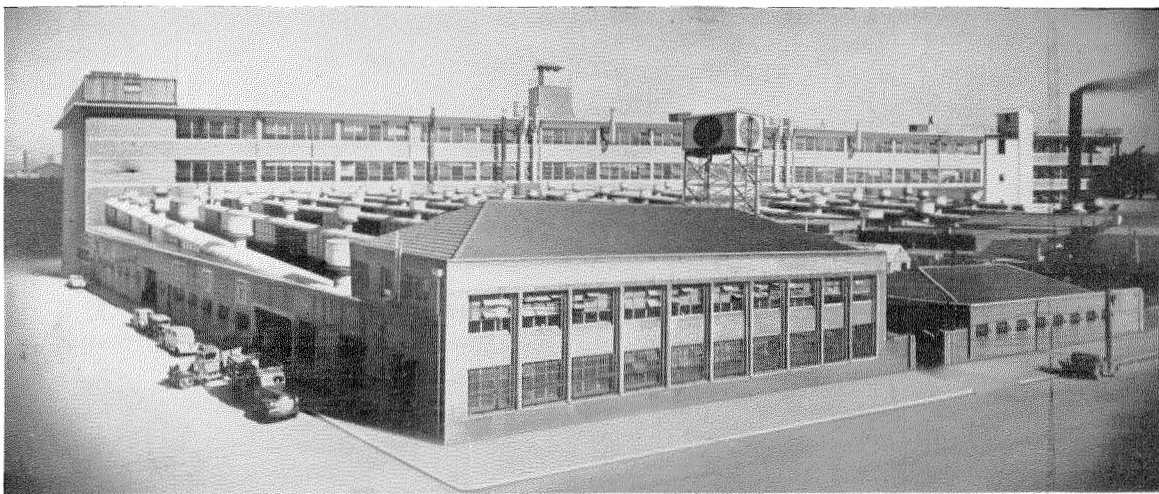

Fig. 1—Standard Telephones & Cables Pty. Ltd. plant as of 1944.

- 1925 Name of Company changed to Standard Telephones and Cables (Australasia) Limited.  
First carrier telephone system installed in Australia, a three-channel system for use between Sydney and Melbourne.  
Received order for 11,200 lines of automatic exchange equipment for the Adelaide area.
- 1926 New Zealand's pioneer broadcasting stations 1YA and 3YA opened with S.T.C. equipment.  
Awarded contract for Australia's first hospital radio installation at Royal Prince Alfred Hospital.  
Supplied carrier telephone equipment for use between Melbourne and Adelaide.  
First public-address system installed in Australia at opening of Anzac Memorial Hall, Mosman, N.S.W.
- 1927 First telephone made in Sydney factory.  
Branch office opened in Wellington, N. Z.  
Supplied public-address system for opening of Federal Houses of Parliament at Canberra by H. R. H. the Duke of York, now King George VI.  
Supplied transmission equipment for station 2YA, Wellington, N. Z.
- 1928 First telephone switchboards made in Sydney factory.  
Supplied equipment to South Australian Railways for first carrier telephone system to be installed by an Australian railway department.
- 1929 Received order from Postmaster General's Department, for manufacture and installation of four regional broadcasting stations.  
Supplied first 33,000-volt underground cable in Australia to Sydney Municipal Council.
- 1930 Awarded contract for supply of 4,500-line automatic exchange equipment for Edgecliffe, Sydney.
- 1931 Adelaide-to-Perth telephone line using S.T.C. repeater and carrier equipment opened for service.
- 1932 Received order for first carrier non-reversible programme system for use on Adelaide-Perth trunk lines.
- 1933 Order received for first reversible two-way carrier broadcast system for use on Sydney-Melbourne trunk line.  
Order received from Postmaster General's Department for four carrier telephone systems.  
Awarded contract for manufacture and installation of equipment for four 7-kilowatt regional broadcasting stations.
- 1934 Awarded contract for manufacture and installation of equipment for three 10-kilowatt regional broadcasting stations.  
Supplied first teleprinters to Postmaster General's Department for point-to-point telegraph service.  
First programme transmission amplifiers made in Sydney factory.  
Awarded contract for carrier and associated equipment to provide telephone, telegraph, and broadcast transmission facilities by submarine cable between Australian mainland and Tasmania.
- 1935 Received order from New South Wales Government Railways for supply of carrier telephone systems for use between Sydney and Bathurst.  
First moulded handset telephone made in Sydney factory.  
Received orders for eight 3-channel carrier telephone systems.
- 1936 Supplied teleprinters for Sydney Stock Exchange ticker service.  
Awarded contract for automatic telephone exchange equipment for North Sydney Main Exchange of 6,400 lines.  
Factory removed from Chippendale to Company's own premises, Botany Road, Alexandria.  
Received orders for twenty-two 3-channel carrier telephone systems.
- 1937 Awarded contract for supply of radio instrument landing equipment for the Defence Department, Australian Commonwealth.  
Secured contract for supply of four national broadcasting stations in capital cities of Sydney, Melbourne, Adelaide and Brisbane.
- 1938 Awarded contract for supply of first 12-channel carrier telephone system between Sydney and Melbourne.

- Contract received for five automatic exchange equipments, totalling 7,750 lines. Awarded contract for supply of ten 3-channel and twelve single-channel carrier telephone systems.
- 1939 Secured order for one national and two regional broadcasting stations. The order for the first carrier systems to be made in the Australian factory was received and consisted of two 3- and two single-channel carrier telephone systems.
- 1940 Contract received for trunk cable between Melbourne and Seymour, being the first section of a trunk cable to be laid between Melbourne and Sydney. Contract received for manufacture of high-frequency broadcasting station.
- 1941 Contract received for supply of automatic exchange equipment for one 2,000-line and one 1,600-line exchange. Received contract for a second 12-channel carrier telephone system between Sydney and Melbourne. Received contract for supply and manufacture of equipment for 100-kilowatt high-frequency broadcasting station.
- 1942 to date. Very large contracts for the Fighting Services and for the Postmaster General's Department have been undertaken during the war period. For security reasons particulars cannot yet be published.

# Simultaneous Use of Centimeter Waves and Frequency Modulation\*

By A. G. CLAVIER and V. ALTOVSKY

*Engineers, Laboratoire Central de Télécommunications, Paris, France †*

## Summary

A BRIEF résumé of the results obtained with electromagnetic waves of centimeter lengths in radio communication is given. Their advantages in permitting high directivity with small antennas and in simplifying the transmission of signals requiring a wide band of modulating frequencies are pointed out. By combining frequency modulation with centimeter-wave technique, Laboratoire Central de Télécommunications, previously known as Les Laboratoires, Le Matériel Téléphonique, has constructed a multi-channel radiotelephone system, constituting a "hertzian cable" section suitable for insertions in a long-distance telephone circuit and of a quality complying with international standards. Specifically, cross modulation was as low as that encountered in the most modern repeatered coaxial-cable systems. Frequency compression, utilizing frequency modulation with reverse feedback, was used. In 1941, a series of tests verified the essential characteristics of centimeter-wave propagation.

## 1. Introduction and Historical Survey

Situated at the limits of the shortest wavelengths employed in radio communication at the moment and near the spectrum of infra-red vibrations, electromagnetic waves of centimeter lengths possess properties relating them both to electric oscillations and to optical phenomena (Fig. 1). This transitional stage is evidenced even in the terminology used: one speaks of antennas and transmission lines, but also of reflectors and lenses. On the other hand, their frequency is sufficiently high for special molecular phenomena to appear in their range, thus accounting for the variation of the dielectric constant of water because of the presence of its

bipolar molecules. This effect, as foreseen by Debye, explains the difference between the value of 80 and the square of the refractive index for luminous waves; it is well known that modern experimenters have begun to verify his prediction. Moreover, the energy quantum associated with their frequencies (a fraction of  $10^{-2}$  electron volts) or their wave number ( $1/\lambda$  of the order of 1 centimeter<sup>-1</sup>), despite its low value, is sufficiently large for recent theories of the properties of matter to place selective absorption bands in this region for certain substances; ammonia gas is an example; Cleeton and Williams have been able to demonstrate the agreement between experiment and these recent theories of physics.

Accordingly, the field of centimeter wavelengths is of great interest both in pure and applied science. Overlapping in these fields, in fact, occurred in Hertz's day when he, both as an engineer and a physicist, sought to verify by experiment the Maxwellian theory which asserts that electrical vibrations and luminous vibrations are physically of the same character. It is not astonishing, therefore, that Hertz contributed to the evolution of scientific ideas and indicated the medium of one of the principal applications, that of radio communication. His experiments with a wavelength of 60 centimeters, in 1887, made use of combinations of antennas and parabolic reflectors (Fig. 2).

The use of very short electromagnetic waves, which from the start seemed to be first on the list of applications, was long delayed because the necessary technical tools were unavailable. On the one hand, over a considerable period, only damped oscillations unsuitable for radiotelephony could be produced in this range; and, on the other hand, exploitation of the properties of longer waves proved so productive that specialists could hardly keep abreast of the problems confronting them. Short waves were never, however, abandoned, and France occupies an important position in this field of research. Under

\* Reprinted from *Bulletin de la Société Française des Électriciens*, Ser. 6, v. 4, n. 35, March, 1944, pp. 1-23. Presented at a meeting of the S.F.E., January 8, 1944, P. Dubertret presiding.

† Formerly Les Laboratoires, Le Matériel Téléphonique.

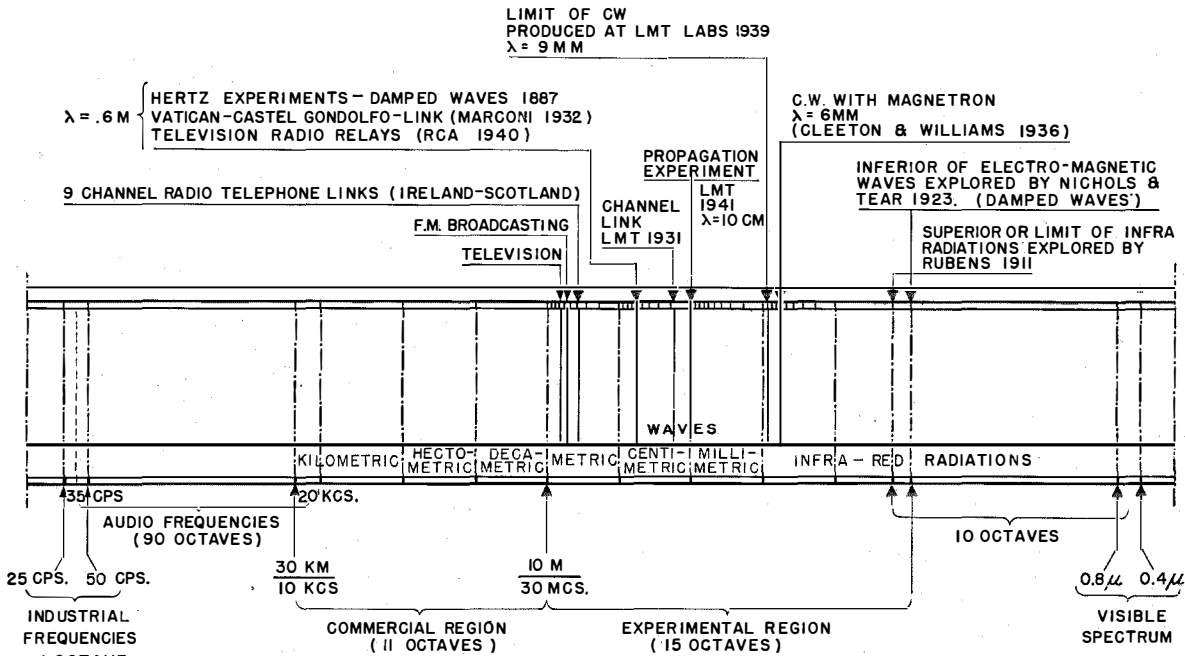

Fig. 1—Short-wave spectrum.

the active leadership of General Ferrié the Laboratoires de la Radiotélégraphie Militaires at Tour-Maubourg succeeded in developing triodes suitable for operation at ultra-high frequencies; the contributions of Camille Gutton and René Mesny in this field are recognized. In 1920, a German professor, Barkhausen, observed the presence of oscillations in vacuum tubes with positive grids and negative anodes; the oscillations, on a 40-centimeter wavelength, were continuous. A few years later, Camille Gutton and Pierret produced continuous oscillations on 18 centimeters. Interest in this field was revived and applications were immediately sought on the part of individual workers and industrial organizations in different countries.

Interesting developments on centimeter

waves recently were presented<sup>2</sup> by engineers of the Société Française Radioélectrique, particularly by Warnecke and Henri Gutton. Laboratoire Central de Télécommunications, in 1929,

<sup>2</sup> Presented before Section 5 de la Société Française des Electriciens.

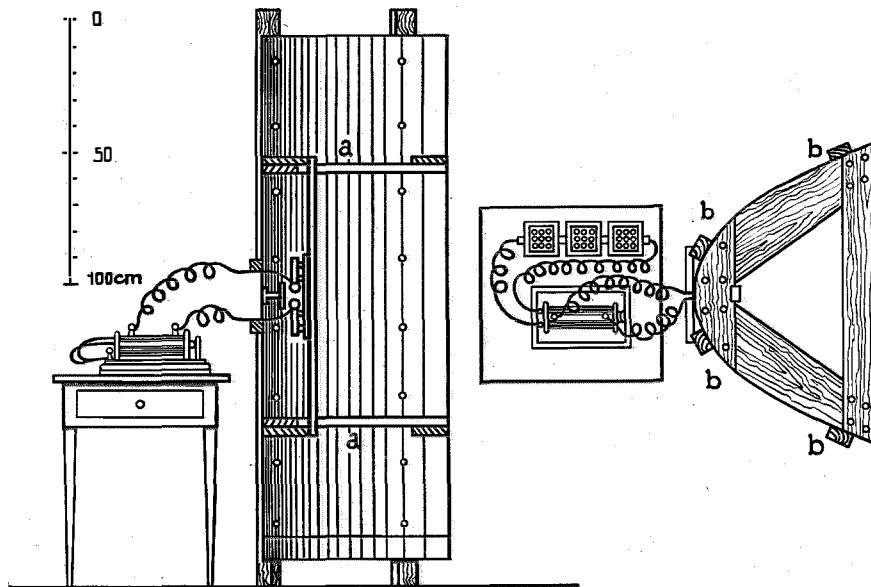
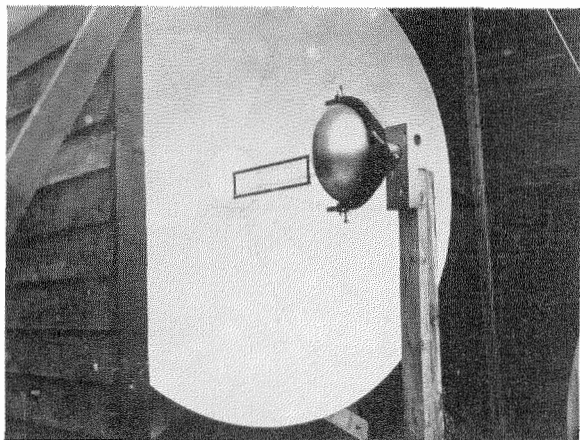
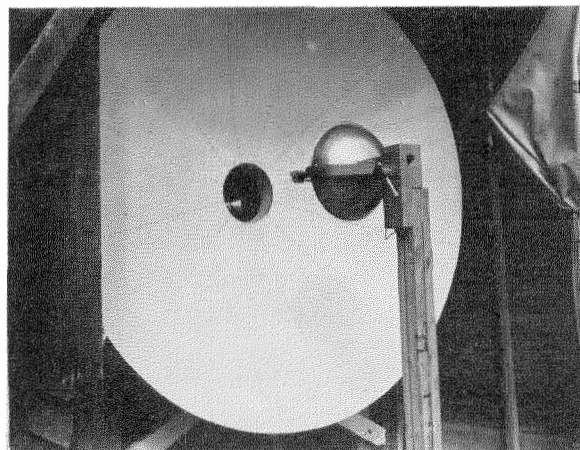
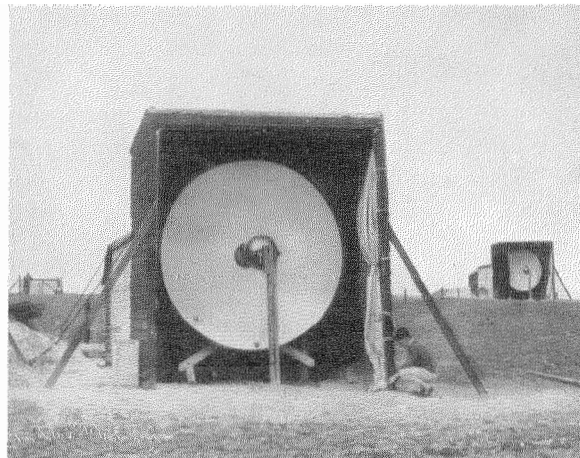

Fig. 2—Sketch made by Hertz.

initiated studies of centimeter waves. In 1930, improved tubes with positive grids were developed which made use of the principle of a balanced circuit, as advanced by Mesny for longer waves,



*Fig. 3—Experiments between Calais and Dover.*

and also incorporated the results of a theoretical study of the effect of transit time between electrodes. This latter investigation involved elements that may legitimately be considered as the initial step in the application of velocity modulation in electron tubes.

The resulting oscillators made possible the experiments between Calais, France, and Dover, England, spanning a distance of 40 kilometers by radiotelephone and telephotography on a wavelength of 17 centimeters (Fig. 3). These experiments, demonstrated in 1931 before prominent research workers, showed the developments since Hertz. They included the use of both reflectors and transmission lines. Impressed by the results obtained, the Air Ministries of France and Great Britain asked Laboratoire Central de Télécommunications to install a link which was opened in 1933 between British and French airports of Lympne and Saint-Inglevert. This was the first commercial application of centimeter waves (Fig. 4).

Technical improvement followed rapidly, particularly in the generation of waves. The positive-grid oscillator was thoroughly investigated in Laboratoire Central de Télécommunications and its properties accurately determined at wavelengths as short as 5 centimeters. Several oscillators were constructed that still are of major importance in laboratory tests and as low-power oscillators (of a few tenths of one watt), particularly for receivers (Fig. 5). Other types of oscillators, however, make it possible to extend the useful range and the available power. Continuous oscillations at 0.9 centimeter were produced (1939) with the aid of a magnetron tube of an entirely new design (Fig. 6). This is very close to the record established in America by Cleeton (0.6 centimeter) and the power is greater (a few milliwatts).

The use of velocity modulation of the electrons enabled the Varian brothers in America to construct oscillators on 30 centimeters supplying up to 1 kilowatt of useful power (1939–1940). Laboratoire Central de Télécommunications soon took up this idea but attempted to produce shorter wavelengths; they constructed an oscillator producing a few watts on 10 centimeters (end of 1939–1940), and used it for propagation experiments which will be discussed below (1941). The power was increased to 50 watts with forced

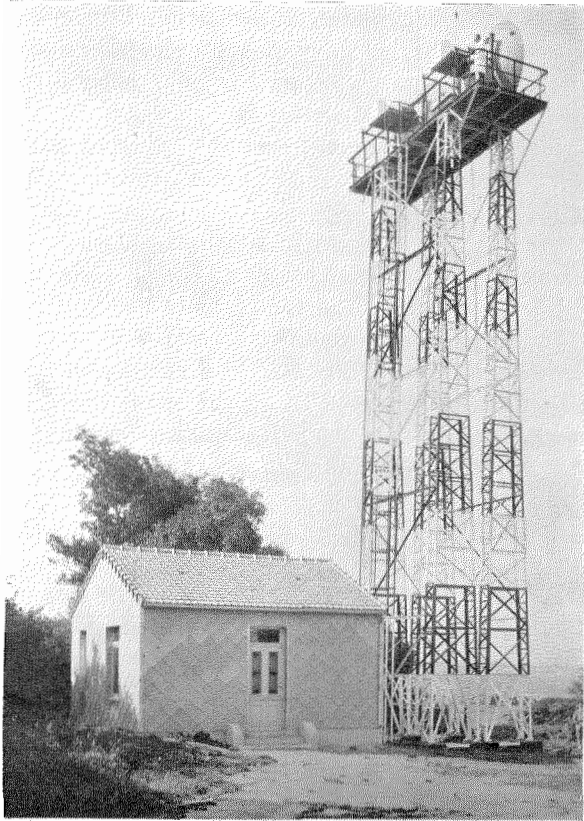

Fig. 4—Saint-Inglevert station.

air cooling (Fig. 7), and to 100 watts with water cooling (1940–1941). The same principle soon made it possible to obtain 25 watts of useful power on 5 centimeters (1942) (Fig. 8).

With the aid of these new devices, the era of distance records in line-of-sight transmission was closed. In the propagation experiments on 10 centimeters in 1941, discussed later, a transmitter supplying 3 watts of useful power could establish contact to the horizon 100 kilometers away with such strength that the line-of-sight range would be several thousand kilometers. Attention also was directed toward the use of centimeter wavelengths for multi-channel tele-

phone transmissions. As a preliminary, it is interesting to note the receiver (Fig. 9) of the multi-channel system constructed in 1942. Its simple lines indicate the developments of the art, the reflector in particular being replaced by a compact projector of great power.

In this last phase of research, Laboratoire Central de Télécommunications had the able support of the French Post and Telegraph Administration and the Communication Coordinating Committee. Without their participation, results that have placed centimeter-wave operation in the field of practical engineering could not have been achieved in France.

## 2. Characteristics and Use of Centimeter Waves

Centimeter waves make possible very marked directivity and its attendant high transmission gain with equipment requiring little space. It is a general law of radiating electromagnetic systems that their directive characteristics are retained if their linear dimensions are reduced in proportion to the wavelengths employed. Thus, when a device has been investigated at a given wavelength, it is of interest to use shorter and shorter wavelengths taking precautions so that other factors, such as the small power available or additional circumstances in the laws of propagation, do not obscure the effects being examined.

The radiating systems used in the experiments thus far were antenna arrays, reflectors, and

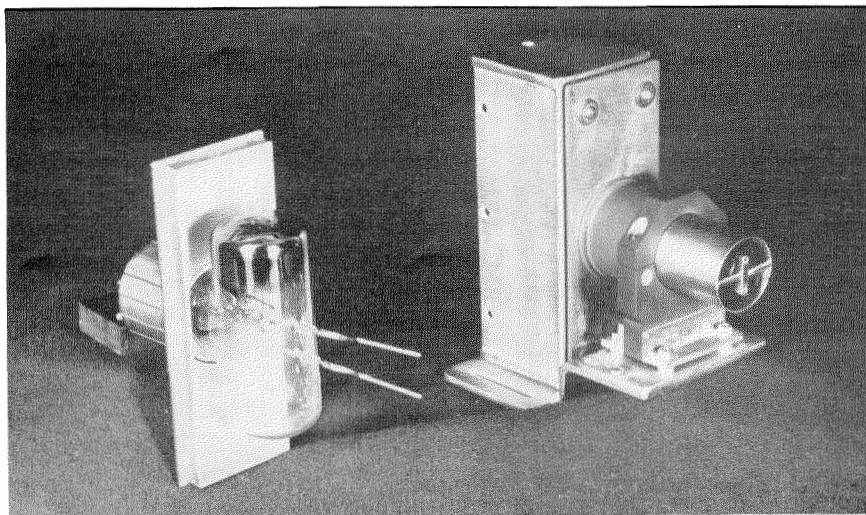

Fig. 5—Positive-grid tube and case.



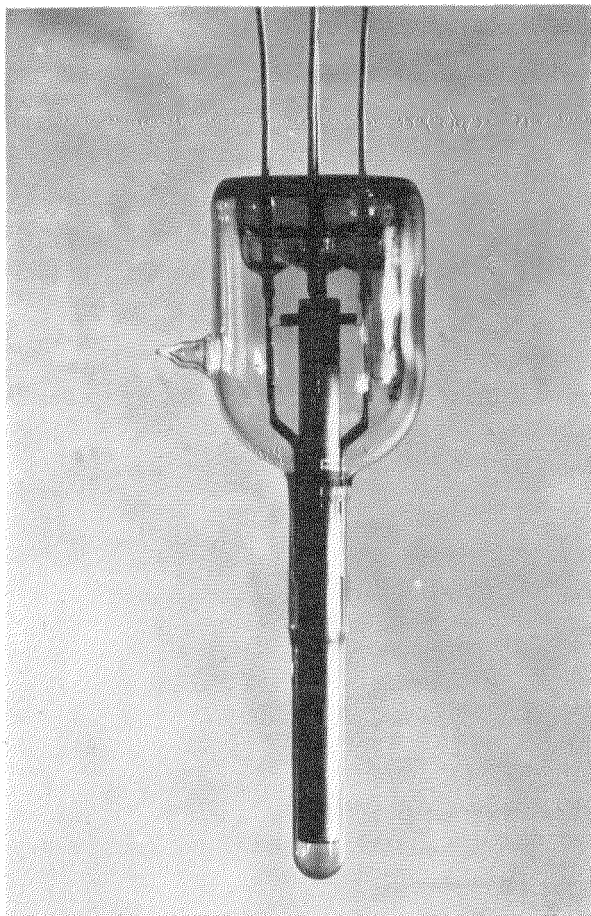

Fig. 6—Magnetron for 0.9-centimeter wave.

projectors. At very high frequencies, the control of the phase of the currents in the different parts of antenna arrays presents difficulties. The use of revolving parabolic reflectors as in the link between Lympe and Saint-Inglevert avoids this trouble but has the disadvantage of presenting directional diagrams which, in addition to a principal configuration, include secondary emissions yielding energy losses, and permitting reception in directions other than those intended.

For the foregoing reasons, electromagnetic projectors were utilized in 1941 in experiments on 10-centimeter wavelengths. The theory of these devices is derived from that of wave guides. It is well known that electromagnetic waves can be propagated in cylinders having conductive walls, provided their frequency is higher than a cut-off frequency determined by the geometrical dimen-

sions of the cylinder. Propagation into space may occur if the walls of the cylinder expand into a horn or a projector. A certain distribution of the electric and magnetic fields may be obtained at the opening, and the radiated fields can be calculated by means of Huyghens' principle.

The technical problem consists essentially in determining the dimensions that will yield the desired distribution in the plane of the opening. While rigorous calculations have been made, earlier experiments by Barrow have shown that the problem, without too great error, could be considered as a horn with walls of unlimited extent, thus neglecting effects caused by sharp transitions in the plane of the opening; that is, assuming perfect adaptation of the horn to the surrounding space.

Guided by the work of Barrow in the case of sectoral horns, two sets of surfaces disposed in pyramidal sections were utilized to form the radiating element (Fig. 10). The theoretical predictions were verified experimentally (1941) with a receiver comprising a demodulator followed by a low-frequency amplifier with a carefully calibrated adjustable gain. A control scale of 66 decibels was available and, taking account of the square law of the demodulator, provided a measurable range of variation of the high-frequency field equal to 33 decibels.

Tests included the variation of intensity of the high-frequency field for different orientations of the transmitting projector on both sides of the axis joining the transmitter to the receiver, both in the horizontal and vertical planes. With the dimensions selected, the following results were noted: the horizontal diagram (Fig. 11) was perfectly regular and subtended an angle of 14 degrees between the two points giving a loss of 3 decibels with respect to the maximum field. No lateral lobe was detected. The vertical diagram gave an angle of 11.4 degrees for the same loss as above. No parasitic lobes were present, but slight lateral enlargements were observed; they decreased with increasing distance, i.e., at 50 meters and 150 meters from the transmitter (Figs. 12 and 13). The spherical radiation diagram of this projector was quite satisfactory; the aperture dimensions were 77 by 60.4 centimeters. The gain relative to a half-wave antenna was 23 decibels.

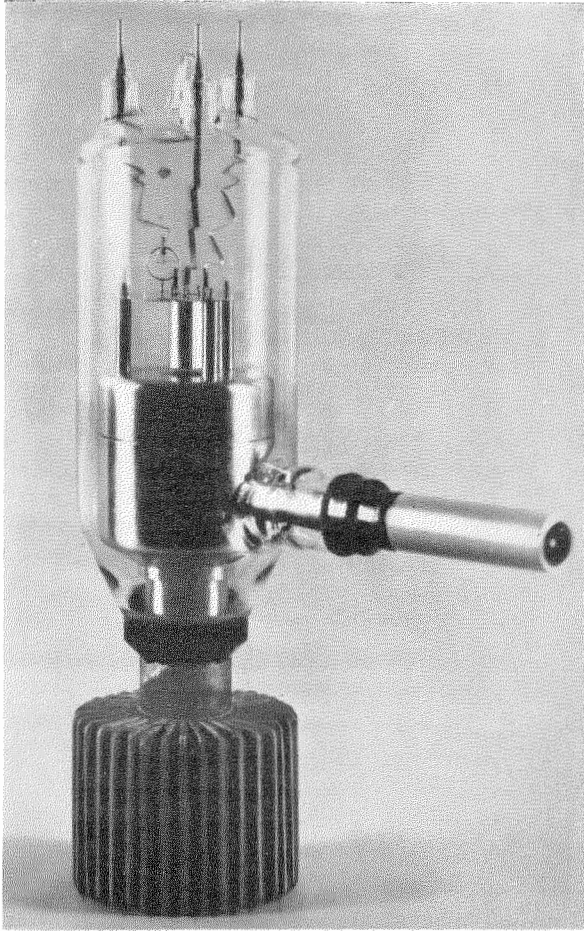

Fig. 7—50-watt tube,  $\lambda=10$  centimeters.

The other outstanding property of centimeter waves is that their very high frequency permits transmission of signals over wide frequency bands. The bandwidth of modulation which may be transmitted increases with the frequency of the carrier. For example, in television, passing a signal bandwidth requiring 10 percent of a carrier frequency of 40 megacycles is difficult; with a carrier frequency of 3,000 megacycles ( $\lambda=10$  centimeters), passing a 1-percent signal bandwidth is relatively simple and still represents about 8 times more than 10 percent at 40 megacycles. Thus, one important application of centimeter waves will be for wide-band systems such as simultaneous transmission of multiple signals on a single carrier. Moreover, if only a single telephone channel is required, very high quality can readily be achieved as was demon-

strated by the 1941 experiments on 10-centimeter waves.

Frequency modulation is particularly advantageous when the index  $m$  (ratio of frequency deviation  $\Delta f$  to the highest modulating frequency  $f$ ) is large compared to unity. It has been shown that the improvement in the signal-to-noise ratio relative to amplitude modulation can be expressed by  $m\sqrt{3}$  for the same carrier level, the same low-frequency modulation band  $f$ , and noise below the signal level.

Hence, frequency modulation doubtless will prove advantageous when frequency bands much wider than  $2f$  are available. This condition occurs more easily at high carrier frequencies which is the reason why simultaneous use of centimeter waves and frequency modulation is likely to be important in the field of radiocommunications.

Other considerations also support this viewpoint. First, it appears that oscillators for centimeter waves are very readily frequency modulated; it is sufficient to vary the potential of an electrode in the vacuum tube controlling the

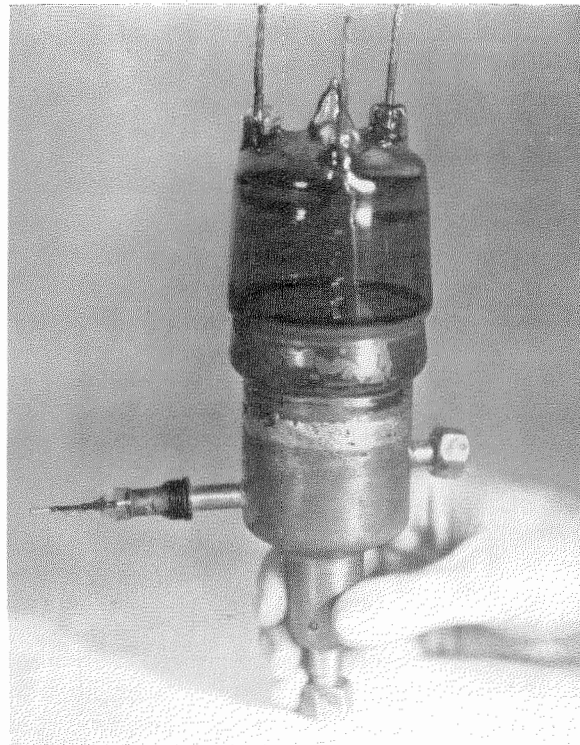
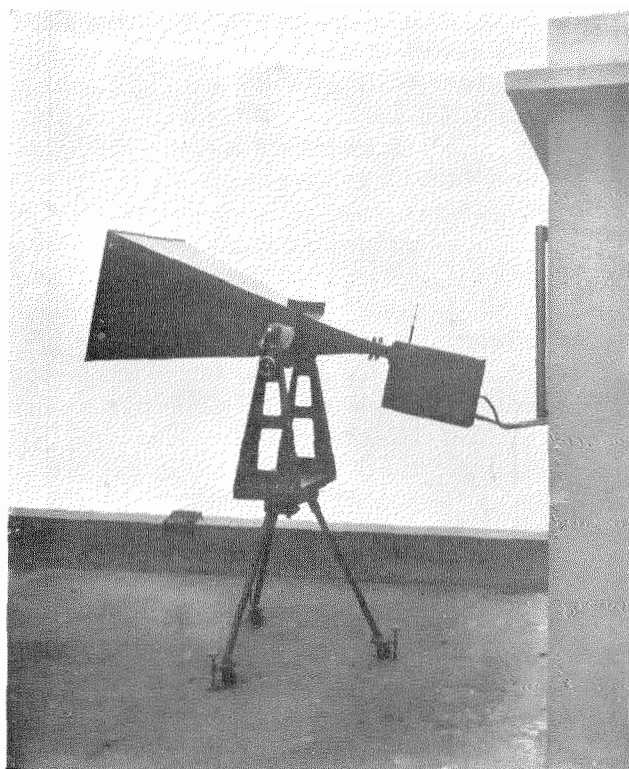

Fig. 8—25-watt tube,  $\lambda=5$  centimeters.



*Fig. 9—Receiving device of the multi-channel system.*

velocity of the electrons. The most typical example is a tube with positive grid where an exactly linear frequency variation can be obtained within a band of  $\pm 30$  megacycles by varying the voltage of an electrode by some tens of volts. This holds also for the velocity-modulated tubes studied: however, the frequency-voltage characteristic was not found linear over as large a range, but was still adequate for multi-channel operation.

To improve the signal-to-noise ratio, frequency-modulation receivers include an amplitude-limiting device which separates the frequency modulation from the amplitude modulation of the carrier wave. Thus, the signal is independent of amplitude variations of the oscillator. Moreover, reception in large measure is unaffected by variations of signal strength at the receiving end. Such variations are often troublesome on centimeter waves. They may result from the interposition of a moving obstacle in the beam path or, in certain cases, from the location of the receiver in a local field subjected to variable and complex interference phenomena.

The foregoing considerations suggest the application of centimeter waves as an alternative for coaxial or other cable systems or as a means for extending circuits requiring a very wide modulating frequency band. They should prove useful as sections of "hertzian cable," capable of accommodating a number of telephone channels on the same carrier wave. This solution offers great advantages for crossing bodies of water where submarine cable is difficult to install and maintain. Engineers also envisage their application to land links in special cases.

The problem presents great difficulties (as was pointed out recently by Mr. Rabuteau in his paper read before the Fifth Section of the S.F.E.) principally in obtaining sufficiently low cross modulation between channels. Nonlinear distortions, generated in the transmitting and receiving elements, cause channel cross modulation which may result in objectionable noise. Estimates indicate that such interference should be 55 decibels below the average speaking level for a high-quality telephone circuit. In carrier-current transmission on cable, it is possible to

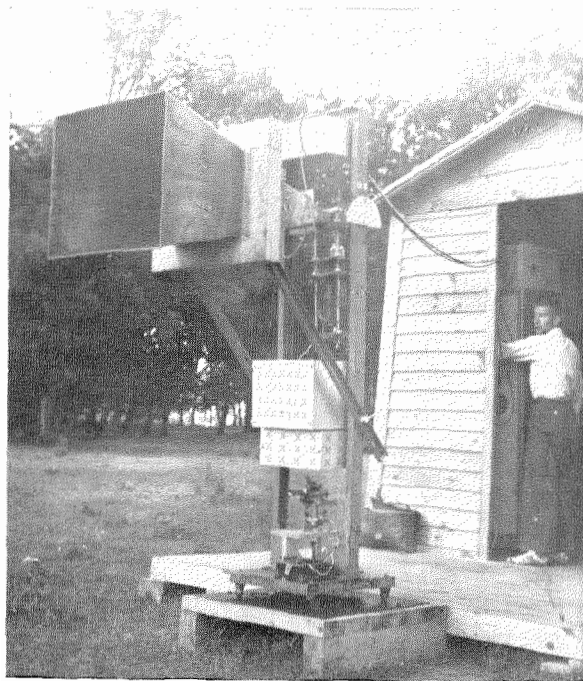

*Fig. 10—Electromagnetic projector used in the experiments in 1941.*

construct repeaters with cross modulation 70 decibels below the speaking level, thus permitting connection of a number of cable sections in series while maintaining the terminal requirements. Obviously, insertion of a "hertzian cable" link will be dependent on meeting the overall system requirements. Recent meter-wavelength installations (since 1937), while few, indicate that it is very difficult in practice to achieve a cross-modulation value lower than 55 decibels.

The possibilities offered by centimeter wavelengths and, in particular, simultaneous use of frequency modulation were investigated. Attention was directed toward extending the Type K carrier-current system. Signals supplied from the cable were used directly for modulating the radio transmitter without demodulation. The radio equipment, in effect, served as repeaters for the short-wave "hertzian cable" section.

Fig. 14 indicates the arrangement utilized; details are not described in the present paper. An essential characteristic was the use, both at the transmitting and receiving ends, of reverse feedback adapted to frequency modulation, permitting cross-modulation values consistent with international standard requirements to be achieved.

To apply reverse feedback to frequency modulation, a small portion of the emitted power was taken from the transmitter output and impressed on a local frequency-changing receiver. This auxiliary signal, demodulated, is applied to the input of the modulating amplifier, in a phase convenient for reducing the frequency variations corresponding to the voltage of the original signal. The ratio of frequency variations, with and without reverse feedback, is the rate  $\tau$  of frequency compression. With equal frequency variation at the output in the two cases, a voltage  $\tau$  times larger is required at the input in the case of compression. However, all parasitic frequency variations, due to the same causes in both cases, are reduced; stability of the average frequency is improved  $\tau$  times and the rate of nonlinear distortion in the transmitter is reduced by  $1/\tau$ .

Overall improvement, nevertheless, can be realized only if the circuit traversed by the auxiliary signal is free from the faults to be corrected. To procure the necessary high quality, sectional frequency compression and the reverse feed-back circuit shown in the illustration were

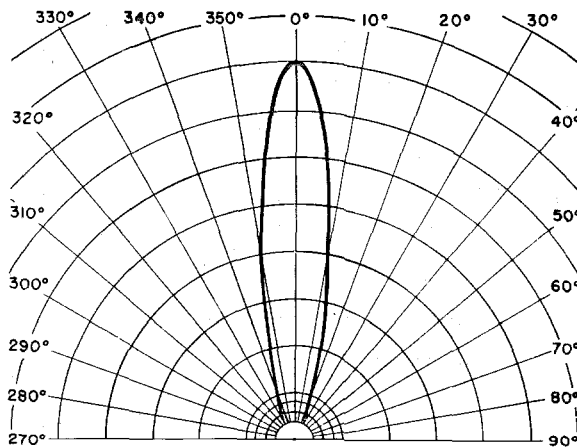

Fig. 11—Horizontal diagram.

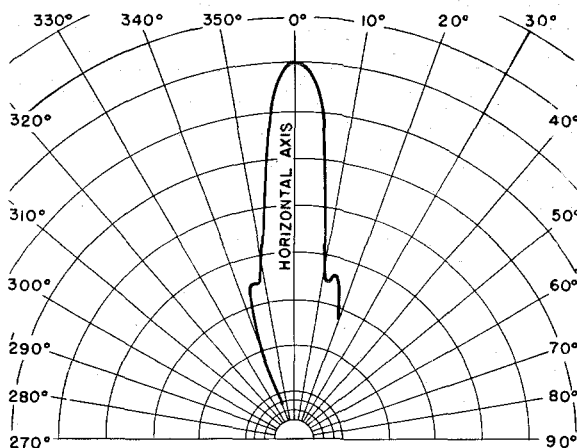

Fig. 12—Vertical diagram.

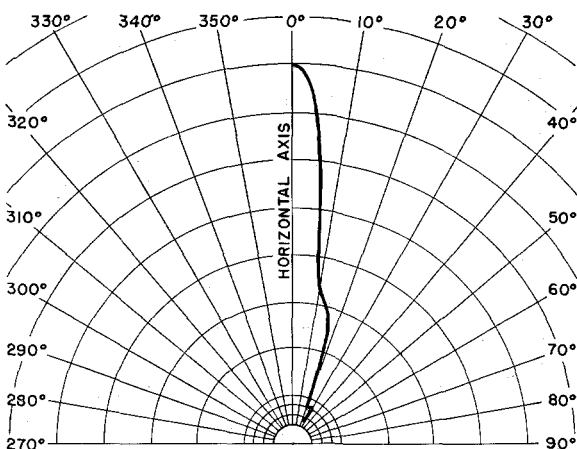

Fig. 13—Vertical diagram.

used; they are incorporated in the general compression loop.

The local oscillator consequently must have a perfectly linear frequency-voltage characteristic; it is obtained by operating a tube with positive grid over only a small section of the straight portion of its characteristic curve. Thus, a linearity standard is obtained, sufficient to satisfy the exacting requirements of the multi-channel system.

The same principle is used at the receiving end with equally favorable results. For a given modulation factor  $m$  of the incident wave, frequency compression makes it possible to reduce the bandwidth of the intermediate-frequency amplifier in the ratio of the compression rate  $\tau$ . Despite this reduction, improvement resulting from frequency modulation as compared with amplitude modulation corresponds to the index  $m$  of the incident wave.

Decrease of the bandwidth of the intermediate-frequency amplifier, moreover, reduces the noise level at the input of the limiter. Hence, the useful range of the receiver can be increased.

Finally, characteristics involving distortions depend, for the receiver as well as the transmitter, on the circuit of the return compression loop and, especially, on the linearity of the frequency-voltage characteristic of the positive-grid tube functioning as a local oscillator.

Experimental results were most satisfactory. Use was made of a 6-channel terminal from the Post and Telegraph Administration (Marzin System). The cross-modulation rate between channels provided a safety factor exceeding 60 decibels under average signal conditions. The equipment shown in Fig. 15, therefore, could be inserted in a communication line of international quality. The equipment was easily extended later to 12-channel operation.

It is felt that these results mark the definite advent of centimeter waves and frequency modulation in the field of radio communication. An accurate evaluation of their practical application must depend on experimental verification of the laws governing the propagation of centimeter waves under actual field conditions.

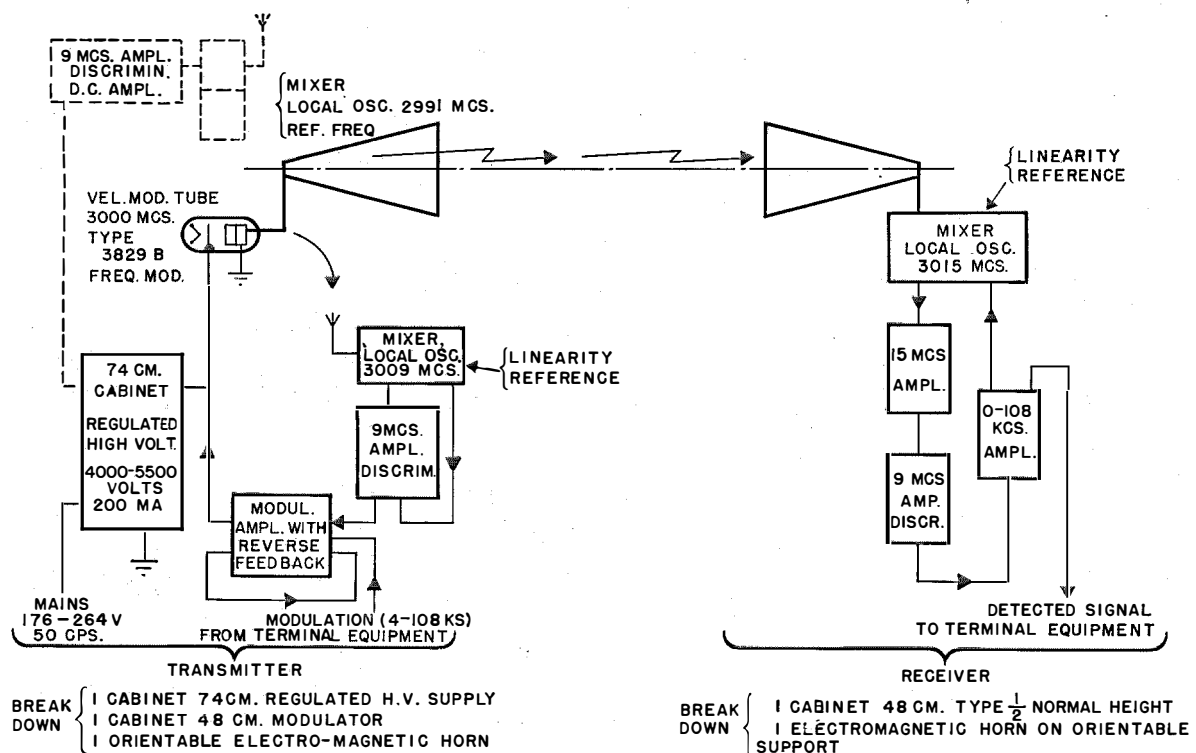

Fig. 14—Diagram of the multi-channel system of Laboratoire Central de Télécommunications on centimeter waves.

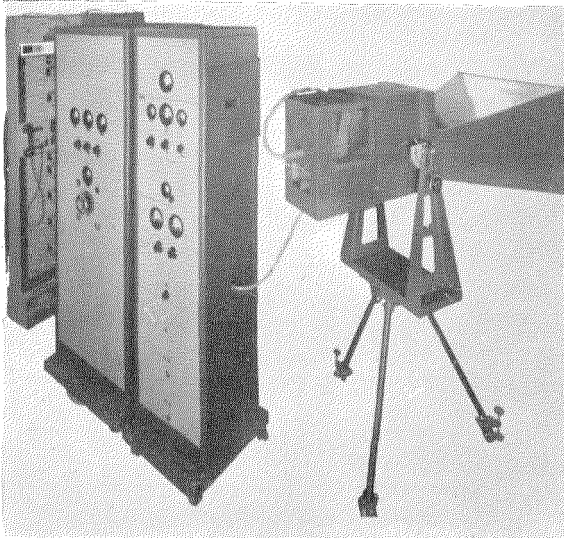

Fig. 15—Multi-channel transmitter.

For this purpose, experiments on a wavelength of 10 centimeters were conducted during 1941. The transmitter delivered a useful power of 3 watts, approximately; a highly directional electromagnetic projector of the type illustrated in Fig. 16 was used. With an elevation of 700 meters at the seashore, its horizon was 100 kilometers. The receiver was installed in a special cabin on shipboard.

Nothing new was noted in regard to propagation to the horizon. In 6 successive tests from September to December, 1941, once the axis of the beam had been contacted, the signal was always followed without difficulty to the horizon at 110 kilometers from the transmitter. (The height of the receiver above sea level was taken into consideration.) At this distance the margin of response of the frequency-modulated receiver remained practically constant at 30 to 35 decibels above limiter level. Compared with earlier experiments on a shorter range between two points on land, this order of magnitude has enabled us to postulate a law of decrease of the field, in inverse ratio to distance as theory would indicate. The margin of response was so high that a positive-grid tube was adequate for transmission to the horizon. A frequency variation of  $\pm 1$  megacycle insured a signal-to-noise ratio of more than 60 decibels at the receiver for the single

telephone channel employed, provided the limiter was operated by the carrier.

Because of the highly gratifying reception obtained at the horizon, propagation phenomena of centimeter waves at much longer distances were investigated. Beyond the horizon tests disclosed two types of distinctly different propagation.

Favored by fine, warm weather and a calm sea, transmission started when the vessel left port in the morning and continued until 8:45 P.M.; alternately, records, spoken words, and 1,000-cycle signals were used. Variations of the incident fields were recorded by measuring devices placed ahead of the limiter of the frequency-modulation receiver. Up to the horizon, variations of incident field of small amplitude were noted; their periodicity corresponded to the slow rocking of the boat. After passing a few kilometers beyond the horizon, much more intense fluctuations occurred with maxima of the order of the level recorded at the horizon and pronounced minima of brief duration. Since these minima did not reach the operating threshold of

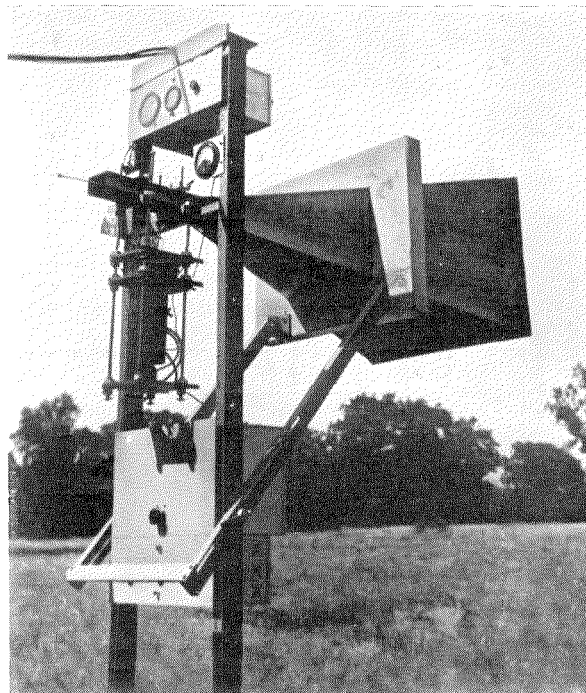

Fig. 16—Transmitter used in the experiments in 1941.

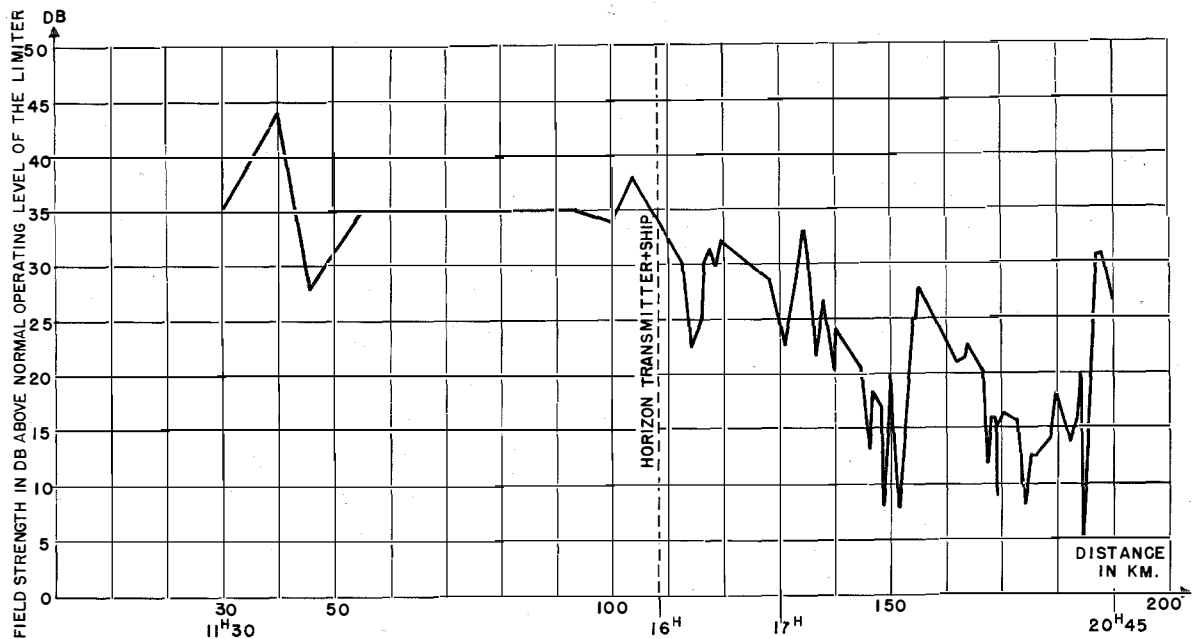

Fig. 17—First propagation experiment.

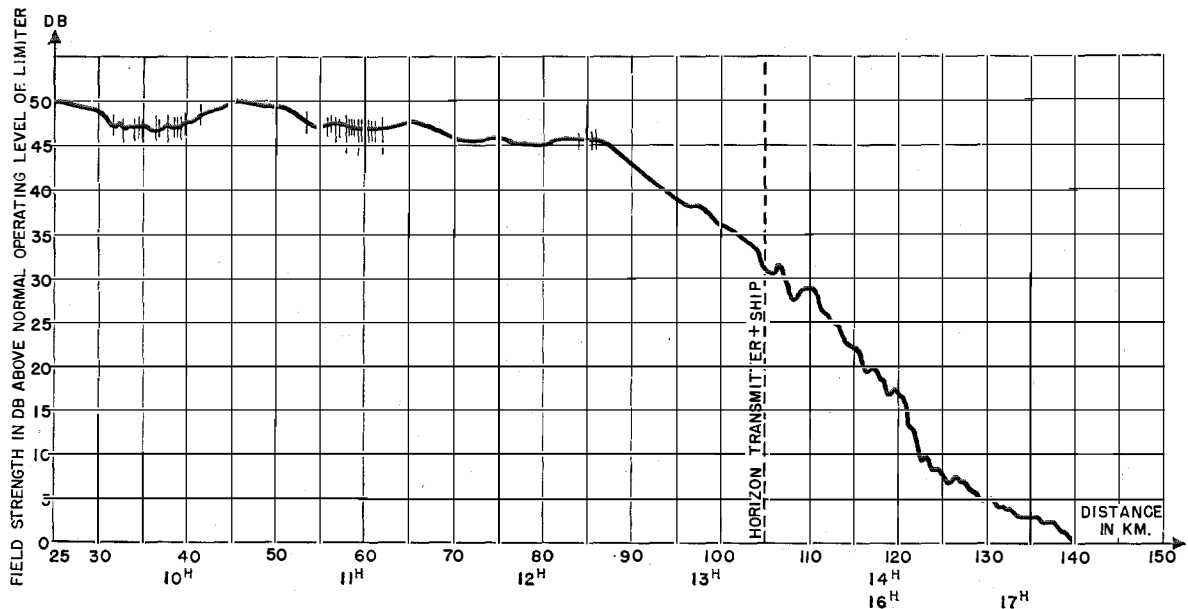

Fig. 18—Second propagation experiment.

the limiter, reception (which is insensitive to such variations) retained the same quality as at 10 kilometers from the transmitter—proof of the advantage of frequency modulation on centimeter waves. With amplitude modulation, the

quality of transmission would have been impaired seriously. Fluctuations continued to the end of the test period when the ship was 190 kilometers from the transmitter or 80 kilometers behind the horizon. The average sensitivity mar-

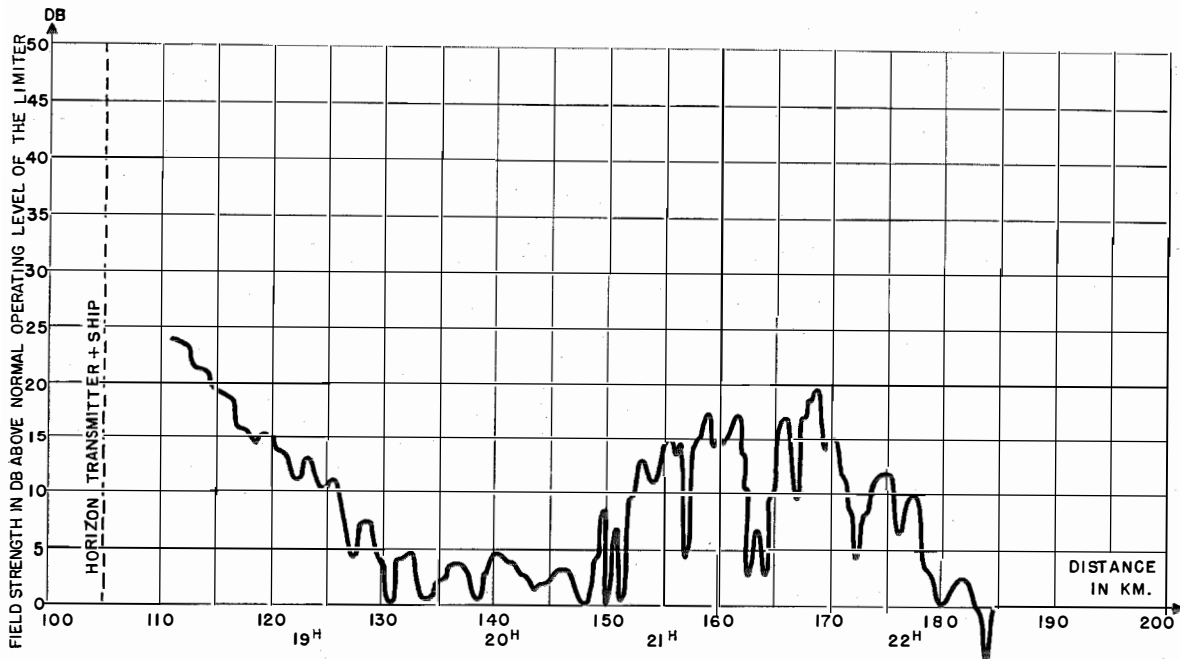

Fig. 19—Third propagation experiment.

gin at the receiving end was still considerable. The experiments did not permit estimating the limiting range of transmission (Fig. 17).

Other experiments were made on the same route under different atmospheric conditions and with rough or very heavy seas. Reception was not modified up to the horizon. Beyond the horizon, on the other hand, instead of the variations previously mentioned, a regular and comparatively rapid decrease of the signal was observed with loss of contact with the transmitter at 170 kilometers, i.e., 60 kilometers beyond the horizon. Although listening was continued for a long time after the signal had vanished, audible reception did not recur.

A final series of experiments made it possible to verify the two above-mentioned modes of propagation during the same voyage within a few hours. Experiments were performed following a period of very rough weather which turned fine on the day of departure. Transmission tests as usual started as soon as port was left behind, the level of the incident field being indicated by an automatic recorder. The type of propagation with uniform decrease was found beyond the horizon (Fig. 18).

Atmospheric conditions meanwhile had gradually improved, both at sea and in the vicinity of

the transmitter where fair weather with no wind was reported. On the other hand, abnormal conditions of optical refraction could be observed at the horizon. The vessel returned and the experiment was resumed at about 110 kilometers from the transmitter. First, a very uniform decrease of level was observed, but commencing at 150 kilometers the level started to increase and to exhibit variations (Fig. 19). Although less pronounced than in the first experiment described and verified only up to 80 kilometers beyond the horizon, these variations without a doubt made it possible to connect the phenomenon with the first type of propagation observed in our experiments. This type of propagation, which might be called irregular because it is not explained by the theory of propagation in isotropic media, in all probability is governed by the variations of optical characteristics resulting from more or less pronounced stratification of the atmosphere at sea level. The use of highly directional projectors at the transmitting and receiving ends eliminates the hypothesis of an upper-atmospheric effect which, moreover, is hardly probable.

The experiments described above seem to show the essential characteristics of the propagation of 10-centimeter waves. While incomplete they,



nevertheless, furnish essential indications relative to the application of these wavelengths in practical engineering. The waves seem particularly suitable for working within the visibility range; reliable extension of the range would necessitate the use of relay stations, the engineering possibilities of which are now under investigation.

Extrapolating from theory or previous experiments in optics, it would seem that the lower limit of useful wavelengths is influenced by increasing absorption by snow and fog. The wavelength for which such absorption becomes notice-

able for application to radio communication is generally regarded as 5 centimeters. Verification of theory by experiment is certainly justified inasmuch as use of the shortest waves would permit a corresponding reduction in the dimensions of the radiating devices with equal directivity.

Rapid increase in the utilization of centimeter waves in radio communications is highly probable. Progress achieved since the Lympne-Saint-Ingelvert installation in 1933 is decisive and "hertzian cables" probably will find wide application as soon as world conditions become more normal.

### Erratum, Volume 22, Number 2, 1944

#### CATHODIC PROTECTION AND APPLICATIONS OF SELENIUM RECTIFIERS

Page 135, first paragraph, under "Open-Tank Condensers," should read as follows:

"This principle is illustrated by the application of cathodic protection on open-tank condensers in oil refineries where expensive corrosion occurs on the submerged coils. The anodes used consist of sets of steel plates (sometimes carbon rods) submerged vertically in the condenser tanks, extending down close to the bottom. The plates are suspended from horizontal beams or pipes which rest on insulating supports. Positive busses run to the supporting beams, the negative busses being connected to the tank and the headers of the coils. All connections are soldered or welded. Here again selenium rectifier units are particularly suitable for use as a d-c power source because they take up little space in the refinery and are readily adjustable to the required current without appreciable loss of efficiency."

# Thyratrons and Their Applications to Radio Engineering\*

By A. J. MADDOCK, M.Sc., F. Inst. P., A.M.I.E.E.

*Standard Telephones and Cables, Ltd., Radio Division, New Southgate, England*

## Foreword

IT is the purpose of this paper to present a review of the principal applications of thyratrons in the field of radio engineering. Certain applications described belong to that field of power engineering closely allied with radio work, such as high-tension supply sources, whilst others describe instruments used in ancillary capacities.

It is hoped that material presented in this form, together with references to original papers, will indicate the main lines on which developments have already proceeded. At the same time a study of these circuits may suggest to the reader new applications or possible solutions of some particular problem.

For the sake of completeness, the earlier part of the paper is devoted to a brief description of thyratrons themselves, particularly in regard to certain factors to be observed in their use, and to the several methods of control which are possible.

Some other circuits, outside the scope of this review, have been described by the author in summarised form in another paper.<sup>1</sup>

The author is grateful to his colleagues, Messrs. W. L. McPherson and F. T. Norbury, for helpful discussions and criticism during the preparation of this paper.

## 1. Introduction

Gas-filled valves with thermionic cathodes may be said to have become a practical possibility around 1928 when Hull<sup>2</sup> announced that, based on work by Hull and Winter,<sup>3</sup> and by Kingdom and Langmuir,<sup>4</sup> any activated cathode could be operated in a gas or vapour discharge, provided the cathode potential drop did not

exceed a certain value designated as the "disintegration voltage." Ions which have a velocity lower than that equivalent to the disintegration voltage do not damage or deactivate the cathode, but higher voltages cause rapid disintegration, principally through active material being knocked off the cathode by the bombarding ions and by sparking at the cathode. Various gases have different disintegration voltages, e.g., 27 volts for neon, 25 volts for argon, and 22 volts for mercury vapour. Fortunately, the disintegration voltage is always higher than the ionisation potential of the gas so that a reasonable working range is available. The practical significance of this is that the instantaneous current in the discharge must never exceed the full emission of the cathode, otherwise the voltage drop across the valve will rise above the disintegration value.

It was immediately evident that a wide field of use was opened up by such valves not only in diode form, in which they are used principally as rectifiers, but also in triode form which permits control of the arc current by means of a grid element. It is the purpose of this paper to review the principal applications in the radio field of gas-filled thermionic valves having three or more electrodes.

No pretence is made to completeness in the references to the literature on the subject, but it is hoped that at least the principal uses will be found listed, that such applications as are given will illustrate the various ways in which these devices may be operated, and that interest in possible other uses will be stimulated.

Gas-filled thermionic triodes and tetrodes have been called "thyratrons" by their originators, and this word, having been generally accepted in scientific circles, will be used throughout this paper.

Because of the low arc drop and the high emission efficiency of the cathodes,<sup>2,5</sup> particularly

\* Presented before the Wireless Section of The Institution of Electrical Engineers on March 1, 1944.

<sup>1</sup> Numbered references will be found on page 377.

the indirectly heated, heat-shielded type, the power losses in thyratrons are small. In the larger sizes, efficiencies of 1 to 1.25 amperes of peak emission per watt of cathode-heating power are obtainable, and cathodes rated at 600 amperes peak emission (100 amperes average) are in use.<sup>6</sup> On the Continent, valves having a peak emission of 1,000 amperes have been made, but for practical purposes 200 amperes is considered a reasonable limit.<sup>7</sup> For normal operation of valves designed for high inverse potentials, the maximum peak inverse voltage varies from 30 kilovolts to 15 kilovolts for valves rated at 5 amperes and 150 amperes peak emission, respectively.

Sectional views of typical thyratrons are shown in Fig. 1, whilst Fig. 2 shows a series of high-voltage thyratrons and, for comparison, a small valve used principally for relay purposes.

Before discussing the applications of thyratrons, a brief description of the principal factors to be observed in their operation will be given. A very useful summary of the conditions to be observed in using gas-filled valves has recently been published.<sup>8</sup>

## 2. Factors Controlling the Operation of Thyratrons

### 2.1 ARC VOLTAGE DROP AND CURRENT

At voltages below the ionisation potential of the gas, the device functions in similar manner to a comparable high-vacuum valve, the anode current increasing with the  $3/2$  power of the anode voltage. This region is, however, very limited and when the field near the cathode exceeds the ionisation potential, ions are generated which then travel towards the cathode, and, by their presence, neutralise the space-charge which would occur under vacuum conditions. The ions contribute little to the current,

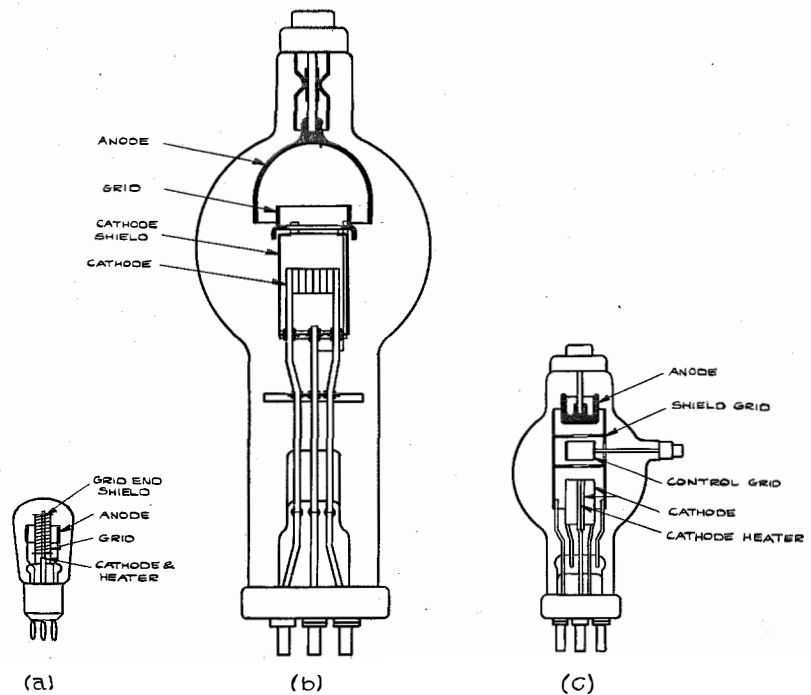

Fig. 1—Sectional diagrams of typical thyratrons.

which is still mainly electronic and comes from the cathode itself. The current thus rises almost instantaneously to a value limited only by the resistance of the load circuit. If a larger current is drawn to the anode, a greater number of ions are produced, maintaining the potential drop across the valve substantially constant at about 8 to 15 volts until the total emission of the cathode is approached. If this is exceeded, the potential rises and eventually reaches a value at which the ions bombarding the cathode possess sufficient kinetic energy to cause disintegration of the cathode. Sparking also may occur at the cathode.

By correlating the results obtained with many mercury-vapour valves, it has been established<sup>9</sup> that there is a maximum current per unit area of cathode surface that can be passed without sparking. The value of this current is a function of the mercury-vapour pressure, and indicates the sparking to be a heating phenomenon caused by the energy dissipated in the electrical resistance of the coating, or by the positive-ion bombardment, or both. Sparking is usually localised and probably results from an unstable condition within the tube since concentration of the current to any one part would be in conflict

with the behaviour under nonsparking conditions which indicates that every part of the cathode area contributes equally to the total emission.

Sudden extinction of the arc may occur if the demand for current is greater than the current-carrying capacity of the gas or vapour path.<sup>10</sup> This has a definite value dependent only on the product of the vapour density and the cross section of the current path. A limit is reached when, in some portion of the path, all the available atoms of gas are ionised and are serving to neutralise the space-charge. An unstable condition results. The ions move to the walls, under the influence of the potential difference that always exists between space and the walls; momentarily this leaves the space almost gas-free, thus interrupting the supply of ions and the flow of current. The ionised atoms lose their charges at the walls and return to the space to be ionised again and swept out. The process repeats indefinitely.

The gas limitation, as it is called, occurs when the current rating is exceeded by (a) the vapour pressure being allowed to fall below the specified value, thus decreasing the current-carrying capacity (see also Sub-Section 2.4) and (b) excessive current being passed through the valve, e.g., during short-circuit conditions. Surges will not occur if the circuits are designed so that the short-circuit rating of the valve is not exceeded and provided the temperature is not allowed to fall below the values stated by the manufacturer.

2.2 EFFECTIVENESS OF THE GRID

Before ionisation sets in, operation is similar to that of a high-vacuum valve; the more negative the grid potential, the greater may be the anode potential before current begins to flow. The ratio between the anode and grid potentials, for the point at which anode current (in discharge form) commences to flow, is termed the "control ratio" and, except for low values of voltage, is practically constant for a given vapour temperature. In distinction to a vacuum valve, where the amplification factor represents a rate of change, in the gas-filled valve the corresponding coefficient (the control ratio) is the ratio of two quantities only, i.e.,  $M = |E_a/E_g|_{i_a=0}$ . A typical illustration is given in Fig. 3 which

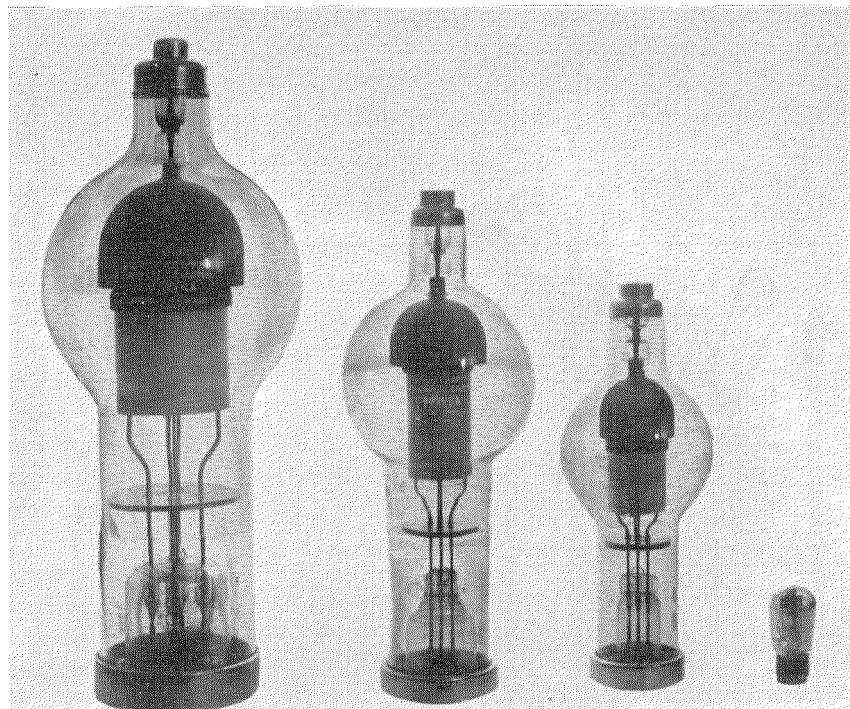

Fig. 2—A range of high-voltage thyratrons, with a small relay thyatron for comparison. Ratings of the tubes, reading from left to right are:

	(a)	(b)	(c)	(d)
Peak Inverse Voltage	16,000	20,000	20,000	500
Peak Anode Current (amperes)	50	20	10	0.2
Average Anode Current (amperes)	20	7.5	2.5	0.1
S.T.C. Type No.	4080-GA	4079-GA	4078-GA	4039-A
Control Ratio	1000	1000	1000	40

shows for a number of temperatures the anode voltage versus grid voltage at which anode discharge current begins to flow. The question of temperature will be discussed later.

Once the arc has been initiated, however, the grid loses effectiveness and cannot be used to control the arc current or to extinguish it even though made highly negative. The value of the current depends only on the anode load impedance and the applied voltage, and the arc can be extinguished only by reducing the anode voltage below the ionisation potential or by making it negative.

When the grid is made negative, positive ions are attracted to it and form a positive-ion sheath around the grid. This neutralises its control effect in the arc space, a greater negative potential on the grid merely increasing the thickness of the sheath. In some special tubes, however, with very close-mesh grids it has been possible to extinguish the arc by an increase of negative grid potential, but, as this does not apply to the

normal type of valve capable of passing large currents, it will not be discussed further.

With a direct-current anode supply, the arc current can thus only be stopped either by disconnecting the supply, allowing the anode potential to drop below the ionisation potential, or by giving a negative impulse to the anode of sufficient duration to ensure that deionisation of the space shall have occurred before the potential again rises to the striking value. On an alternating-current supply, the potential automatically falls below the requisite value at the end of each positive half cycle, and the grid may therefore regain control, provided the negative half cycle of the alternating voltage is of sufficient duration to permit deionisation.

### 2.3 IONISATION AND DEIONISATION TIME

For most practical applications, the time taken to set up ionisation can be neglected as it is of small duration, but a definite lag does occur, depending on the vapour pressure, electrode potentials, and valve geometry. Experiments conducted<sup>11</sup> on several different types of valves indicate that, in general, the time lag varies between about 1 and 8 microseconds. A decrease in vapour pressure not only lengthens the starting time but also makes it more erratic; a negative bias increases the lag, as would be expected. Indications are that a steep wave front of the applied controlling voltage also gives somewhat shorter times of ionisation.

More recent experiments<sup>12</sup> indicate that the lag seems to be made up of two distinct stages, a definite "delay" period in which no ionisation takes place, followed by a shorter "build-up" period after ionisation has commenced and during which the current builds up to full value.

The time of deionisation depends greatly on the geometry of the valve and the potential of the electrodes, and to a certain extent on the circuit. It increases with the vapour pressure and with the arc current that existed prior to the extinction of the discharge. The effects of temperature are referred to in the next Section. Times of the order of 10 to 1,000 microseconds are met with depending on the size and design of the valves. Thus there is an upper limit to the frequency at which each tube can be worked, and for the usual types of thyratrons, with the

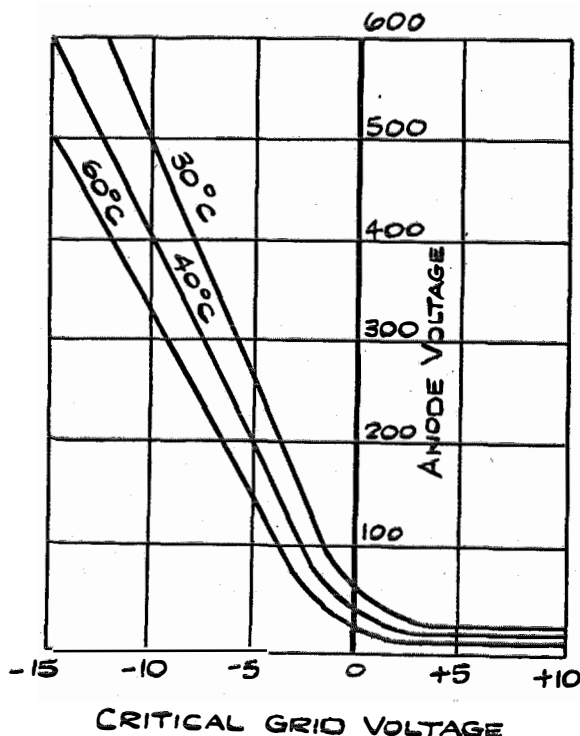

Fig. 3—Grid-voltage—anode-voltage characteristic of a typical thyratron. The critical grid voltage is that at which ionisation occurs.

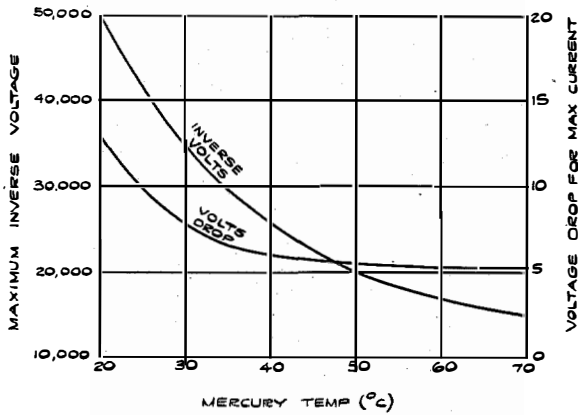

Fig. 4—Variation with temperature of the maximum inverse voltage and the voltage drop in a typical high-voltage thyatron.

deionisation times mentioned, this frequency lies between about 3 and 10 kilocycles per second, though some valves can be used up to 50 kilocycles per second.

2.4 TEMPERATURE EFFECTS

Thyratrons containing inert gases are reasonably free from temperature effects, since the gas pressure is dependent primarily on the pressure at which the valves were filled, and only to a small extent on the ambient temperature or the increased temperature brought about by passage of the discharge. For this reason such valves are used where constancy of characteristics is required without the necessity of temperature control. However, the current and voltage capacities of these valves are low in comparison with valves employing mercury-vapour filling. In most of the applications discussed in Section 4, it is the latter type of valve that will be considered unless otherwise indicated. For simplicity of nomenclature, the word "gas" will be taken to embrace vapour.

In mercury-vapour-filled valves, the vapour pressure depends markedly on the temperature of the coolest part of the valve, i.e., where the mercury condenses. The usual temperature limits for safe operation are between 20 degrees and 70 degrees centigrade depending on the current and inverse-voltage ratings, the optimum being around 41 to 48 degrees centigrade. At these temperatures, the vapour pressure is about 10 microns. Since the temperature of the con-

densed mercury is about 10 to 15 degrees above ambient temperature, the limits for the latter are usually set at 10 to 60 degrees centigrade, again depending on the size of the valve. The effects of temperature (by virtue of its influence on the vapour pressure) are twofold. Firstly, increase of temperature reduces the voltage drop under normal working conditions; secondly, it decreases the inverse voltage that the valve will support because of the greater time needed for deionisation. This increased time results from a slower diffusion process for more collisions occur with the greater number of molecules present. These effects are illustrated in Fig. 4. Excessively low mercury temperatures result in an insufficient number of ions; the voltage drop rises above the disintegration voltage, with consequent deactivation of the cathode. This tendency is indicated<sup>18</sup> by the low-temperature curve of Fig. 5. The disintegration voltage is reached when the temperature of the mercury vapour is somewhat less than 15 degrees centigrade.

Some control of the condensed-mercury temperature is necessary for thyratrons used at high voltage. For medium-sized tubes, a system blowing air at ambient temperature against the base of the valve is used when the ambient temperature rises above about 25 degrees centigrade. It is considered preferable to operate the largest valves at a constant temperature; the air-blowing system is always in operation and a heater keeps the air within about 2 degrees of a temperature

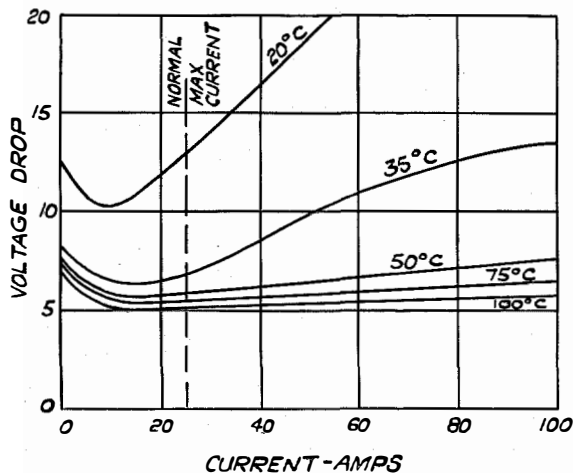

Fig. 5—Variation of voltage drop with current for different mercury temperatures in a typical high-voltage thyatron.

in the optimum operating range of 41 to 48 degrees centigrade.

It is evident from what has been said that the cathode should always be operated at its correct voltage, and recommended delay should occur before the anode tension is applied to any gas-filled valve. This not only allows the cathode to attain its correct operating temperature, but also helps to raise the mercury-vapour temperature to a suitable value.

Sensitivity to temperature in mercury-vapour valves, particularly at high voltages, is in accord with certain physical laws and must be accepted. The advantages of using mercury vapour are so great that this small limitation may be tolerated.

## 2.5 GRID CURRENT AND POWER

The amount of power required in the grid circuit to control large powers in the anode circuit is very small; a photoelectric cell will control even large thyratrons without the intermediary of further amplifiers. However, in some types of thyratrons, a second grid (shield grid) has been added<sup>14</sup> which reduces still further the amount of power required. A reduction to about 1/100th or even less of the value in a triode may be obtained. At the same time, more rapid deionisation is obtained because of the closer spacing of this shield grid to the anode, the shield grid being either connected to the cathode, and so being at zero potential, or having a suitable bias potential applied to it. With such valves, series resistances up to 5 megohms can be employed in the grid circuit, a higher value than can be used with many vacuum valves. One type of construction of a shield-grid thyatron is given in Fig. 1(c), which shows the control grid located between two baffles in the shield grid; since the control grid is small and does not project into the arc stream it collects very little current, but its electrostatic effect on the field distribution enables it to control the arc in the same way as in a single-grid type. The shield grid can also be used to alter the characteristics of such a thyatron between a negative- and positive-control type, e.g., in a particular tube described +5 volts on the shield grid gives a negative-control type, whilst -3 volts converts it to a positive-control type.

It is to be noted that, in all types of thyratrons, the grid current before and after initiation of the discharge is very different. Before initiation the grid current consists of a flow of electrons to the grid, as in a vacuum valve, and is very small (a few microamperes) unless the grid is positive with respect to the cathode. When the arc is struck, the grid current increases considerably in magnitude (many milliamperes) and reverses in direction since it now consists of a flow of positive ions to a negative grid. If the grid is made sufficiently positive, the current will reverse again, increasing rapidly, and if the grid potential reaches the ionising value an arc discharge to the grid will occur. To limit the grid current after the discharge has been initiated, and to minimize the actual grid potential for positive applied voltages, a high resistance is usually connected in the grid lead. Thus the power required to control the thyatron before the arc is initiated is very small, amounting to only a few microwatts even in the larger sizes, and high-impedance grid circuits can be utilised. Once the arc is struck the question of power is of secondary importance since the controlling circuit has then performed its function. Furthermore, the time factor enters into consideration, as the controlling voltage need be applied for a time only sufficient for ionisation to take place.

## 2.6 ARCBACKS

Mention has already been made that the diffusion of ions to the walls and electrodes is retarded at the higher vapour pressures, and hence arcbacks may occur in the early part of the reverse cycle as a result of this residual ionisation. The added function of the grid in clearing the interelectrode space of ions is mentioned in Section 3.3.

Arcbacks may also occur at points in the reverse cycle other than near the beginning, after the space is virtually freed of ions. Kingdon and Lawton<sup>15</sup> propose that arcbacks result from small particles of insulating material on the surface of the anode becoming charged and producing local fields strong enough to cause field emission. Experimental evidence in support of this theory<sup>16</sup> seems to indicate further that, in practical circuits, this charging of small insulating particles is mainly caused by one of two

mechanisms, viz., residual ions or glow discharge. If operating conditions favour the former, then arcback will occur at the beginning of the cycle, whilst in the latter case, it will most often occur at the middle of the reverse cycle when the voltage is at its maximum.

### 3. Methods of Control

Since the grid can only initiate the passage of current between cathode and anode and has no further control once this has occurred, different methods of control, both as regards initiation and cessation, will depend on whether the anode supply is direct or alternating current. In the former case, the anode potential must be brought below the ionisation potential before extinction can occur, whilst in the latter case such conditions occur automatically at the end of each positive half cycle. The definition of alternating current in this case should be taken in its broadest sense to include waves of all shapes occurring at other than zero frequency, e.g., condenser-discharge voltage waves.

#### 3.1 ON/OFF CONTROL OF ANODE CURRENT

Initiation of the discharge by reducing the grid bias below the critical value is well known, and is applicable equally when the anode supply is an alternating or direct voltage. The same principles apply when the grid voltage is alternating or direct for either case of anode voltage.

Another method of controlling the arc for full on/off conditions, when an alternating anode supply is used, is illustrated in Fig. 6. It consists in retarding the phase of an alternating bias from the position of antiphase with respect to the anode voltage. It will be noticed that the arc is first struck at the start of each positive half cycle and current continues to flow until the anode voltage becomes zero. Variation of the phase of the grid voltage in this sense thus gives a sudden change from zero to full current conduction.

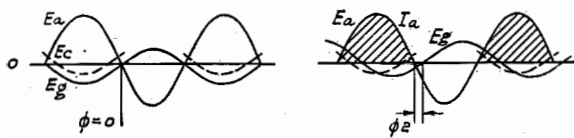

Fig. 6—On/off control with alternating anode voltage.

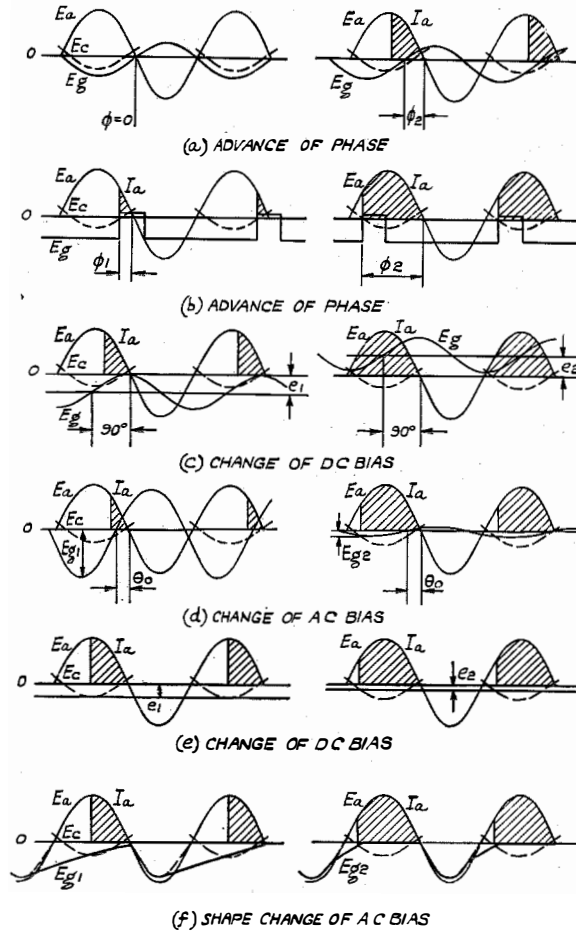

Fig. 7—Variation of mean current with alternating anode voltage.

In this diagram and that of Fig. 7 which follows, the abscissae represent time or electrical degrees, and the ordinates represent voltage or current. The anode current and voltage are drawn of equal value for convenience, the shaded area indicating the time when anode current is flowing.  $E_a$ ,  $E_g$ ,  $E_c$  represent anode voltage, grid voltage, and critical grid voltage, respectively, and  $I_a$  represents the anode current.

#### 3.2 CONTROL OF THE MEAN VALUE OF ANODE CURRENT

Control of the mean value of anode current, when an alternating anode voltage is employed, was originally devised by Toulon<sup>17,18</sup> and consists in advancing the phase of an alternating grid voltage from the antiphase position.



Conduction then commences from a point towards the end of the anode alternating-voltage wave and continues to the point of zero anode voltage. As the phase is further advanced, the angle over which the current flows is increased. Conversely, retarding the phase of the grid voltage from the inphase position will give gradual decrease of mean current.

Other methods of controlling the mean value of anode current have also been devised, and a summary is given below and illustrated in Fig. 7.

- (a) Advance the phase of an alternating grid bias from the position of antiphase with respect to the anode voltage. This gives smooth control from zero to full half-cycle conduction. Fig. 7(a).
- (b) Raise the direct-current bias suddenly to a value below the critical bias, at regular intervals synchronised with the anode alternating-current frequency, and advance the phase with respect to the anode voltage, commencing at the end of the alternating-current wave. This gives smooth control from zero to full half-cycle conduction. Fig. 7(b).
- (c) Raise the direct-current bias, on which is superposed an alternating-current bias of fixed magnitude and fixed phase of 90 degrees in advance of the antiphase position, with respect to the anode voltage, from a negative value greater than the sum of the peak of the alternating-current bias and the critical bias, to a positive value at least equal to the peak of the alternating-current bias. This gives smooth control from zero to full half-cycle conduction. Fig. 7(c).
- (d) Decrease the magnitude of an alternating-current bias, which is advanced in phase with respect to the anode voltage from the antiphase position by a fixed amount, e.g., 30 degrees. This gives smooth control between approximately  $\frac{1}{8}$  cycle (corresponding to the 30 degrees) and full half-cycle conduction, but it cannot reduce the current to zero. Fig. 7(d).
- (e) Raise the direct-current bias from a value greater than the critical bias for the peak of the alternating anode voltage to a value below the critical bias corresponding to the ionisation potential. This gives a sudden

change of conduction from zero to  $\frac{1}{4}$  cycle and thence smooth control up to full half-cycle conduction. Fig. 7(e).

- (f) Increase the gradient of an asymmetrical bias voltage so that the point of intersection with the critical bias is advanced with respect to the end of the anode voltage wave. This gives control from approximately zero to full half-cycle conduction. Fig. 7(f).

### 3.3 GENERAL NOTES ON CONTROL CIRCUITS

Not all of these circuits are of equal value, and the extent to which each type is used may be gauged from the applications described in Section 4.

Since the critical grid voltage may vary with temperature, accurate timing of the point at which the arc is initiated cannot be expected if the grid voltage approaches this value in a gradual manner. Wherever possible, the grid-voltage curve should cut the critical-bias curve at a steep angle. In this respect, for example, schemes 7(a) and 7(b) are superior to 7(e) or 7(f). If a slow approach to the critical bias must be made, a valve should be selected having only a small change of control ratio with temperature, or the temperature should be maintained within fairly narrow limits. The method of 7(b) is very accurate as regards timing because of the steep rise of grid voltage; the pulses are often obtained from a peak-wave transformer which will be discussed later.

Further consideration as to how some of the wave shapes are produced in the grid circuit will be deferred until examples of complete circuits for particular uses are given in Section 4.

It will be evident from the diagrams, and particularly by comparing Figs. 7(a) and 6, that gradual control of the mean anode current is effected by allowing current to flow at the latter part of each positive half cycle, an increase of current being obtained by extending the angle of current flow from the end of the anode voltage wave. Control at the start of the wave allows only full on-off conduction without any gradual variation.

It is opportune to discuss here some simple methods of effecting this phase control of the grid voltage, since many of the examples which

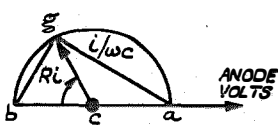
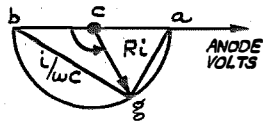
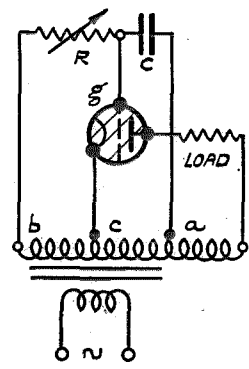
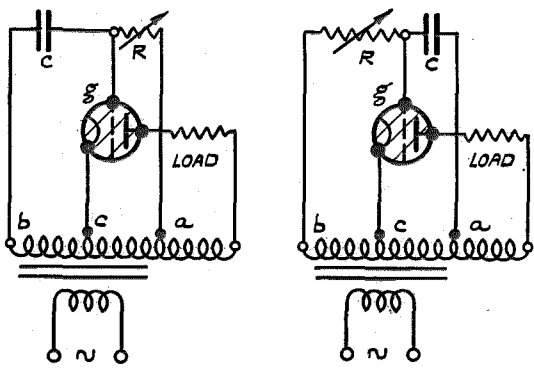

Fig. 8—Phase-control circuits using capacitance and resistance.

- (a) As  $R$  is decreased, the phase is advanced from the antiphase position. Hence, gradual increase of current.
- (b) As  $R$  is increased, the phase is retarded from the antiphase position. Hence, the sudden change of current to full value.

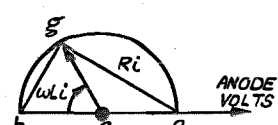
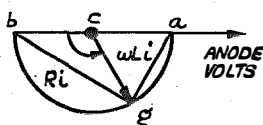
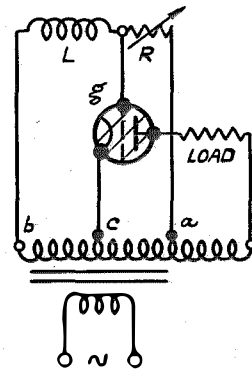
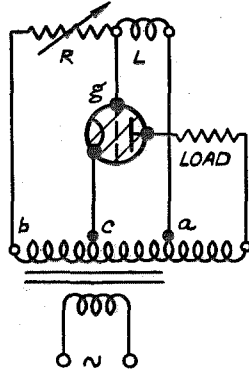

Fig. 9—Phase-control circuits using inductance and resistance.

- (a) As  $R$  is increased, the phase is advanced from the antiphase position. Hence, the gradual increase of current.
- (b) As  $R$  is decreased, the phase is retarded from the antiphase position. Hence, the sudden change of current to full value.

follow in the later sections are dependent on this principle.

The well-known combinations of resistance and capacitance, or resistance and inductance, one of which is varied to change the phase, provide such control. Typical combinations are shown in Figs. 8 and 9. Fixed voltages in phase and 180 degrees out of phase with the anode-voltage supply are applied to a series combination of such elements, the voltage for the grid, of variable phase, being obtained from the point of connection of the two elements. The diagrams shown are for equal voltages with reference to the thyatron cathode and the well-known circle vector diagrams are obtained. It will be seen from some of the later examples, that the opposing voltage may be obtained from the cathode heater voltage (when indirectly heated valves are employed), or from an extension of the main or thyatron cathode-heating transformer.

Fig. 8(a) shows a series combination of capacitance and resistance, the latter being variable. With  $R$  substantially infinite, the grid voltage is in phase opposition and no anode current flows. As  $R$  is decreased to zero, the phase ad-

vances to the inphase position thus giving progressive increase of conduction as in Fig. 7(a).<sup>\*</sup> Alternatively, the resistance may be fixed and the same control obtained by decreasing the condenser value. The reverse process obviously gives progressive decrease in the conduction period from the fully conducting position. If the resistance and capacitance are interchanged in position, as in Fig. 8(b), then, with zero resistance, the grid is in phase opposition with the anode voltage and no anode current flows, whilst increasing  $R$  results in the phase being retarded so that a sudden change to full conduction occurs as in Fig. 6. As before, the condenser may be the variable element, so that increase of capacitance causes the sudden change to full conduction. Similar effects are obtainable with resistance and inductance as in Figs. 9(a) and 9(b), the former showing the disposition of the components for a gradual increase of conduction brought about by increasing the value of the

<sup>\*</sup> The expression for the phase angle  $\phi$  of the current in  $R_2$  between grid and cathode (resistance  $R_2$  is usually the primary of the grid transformer) is

$$\phi = \tan^{-1} \frac{X_c}{R} + \tan^{-1} \left( \frac{X_c}{R} - \frac{X_c}{R_2} \right) - \pi$$

which shows the importance of the value of  $R_2$ .

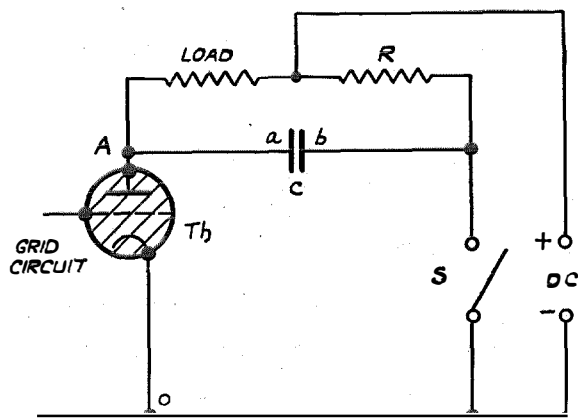

Fig. 10—Extinction of arc with direct-current anode supply.

resistance or decreasing the value of inductance, whilst the latter gives phase retardation and hence a sudden change to full current as the resistance is decreased or the inductance is increased.

For installations involving polyphase alternating-current supplies, the necessary phase shift can be obtained by rotation of the secondary windings of transformers with respect to the primaries. Other methods brought about by changes of direct-current bias, etc., will be dealt with under the particular applications of Section 4.

With direct-current anode supplies, an ingenious and simple circuit<sup>5</sup> for extinguishing the arc, and one which is used as the basis of many circuits, is shown in Fig. 10. Assuming that anode current is flowing through the thyatron, condenser  $C$  becomes charged, through  $R$ , to the potential drop across the load, i.e., to a voltage equal to the supply voltage less the valve drop across  $Th$ , and with the plate  $b$  much more positive than  $a$ . If it is now desired to extinguish the arc, the grid is made sufficiently negative to prevent re-ignition, and then switch  $S$  is closed thus connecting  $C$  directly between the anode and cathode of the thyatron, with plate  $b$  to the cathode, thus effectively applying a large negative potential to the anode with consequent stopping of the current flowing through the valve. The value of  $C$  must be large enough to allow sufficient time for deionisation to occur in the valve before the condenser discharges and charges in the opposite direction to a value

which would again initiate the arc. This value, obviously, must be inversely related to that of the load resistance. Some further comments on this circuit and the wave forms obtaining, are discussed in Section 4.2.2(a).

Switch  $S$  may be replaced by a second thyatron. When this second valve is allowed to strike, by variation of its grid potential, the first is extinguished through the intermediary of condenser  $C$ , and similarly, when the first thyatron strikes the second is extinguished. The combination thus offers an instantaneous on/off switch considering one thyatron of the pair, or a changeover switch considering both valves.

Another function of the grid circuit, particularly with high-voltage thyatrons where arcbacks may tend to occur, is to assist in the rapid deionisation of the inter-electrode space during the time when the valve is essentially non-conducting. The grid should assume a high negative value soon after "firing" has occurred and remain negative during the time the anode itself is negative. The positive ions will then be cleared rapidly before the anode reaches its peak negative value and the chance of arcbacks will be reduced considerably. Another function is to promote deactivation of the grid which may tend to become emissive if active material from the cathode can be deposited thereon; the grid should be negative when the tube is conducting so that it is bombarded with positive ions.\*

To prevent spurious firing of a thyatron, as a result of disturbances in the supply voltage or when anode tension is applied suddenly, it is advisable to connect a condenser, large compared with the grid-anode capacitance, between the grid and the cathode. This will usually ensure that only a very small disturbing voltage will appear between the grid and the cathode as a result of the current flowing across the anode-grid capacitance.

#### 4. Applications of Thyatrons in Radio Engineering

Analysis of the applications of thyatrons is somewhat difficult owing to their diverse nature and the wide field of application already covered. Table I divides them into four groups, and some

\* For a paper dealing with impulses for grid control see reference 19.

of the principal uses in the radio field are also summarized therein. A more-detailed description of these applications and special circuit requirements are given in the sections that follow.

4.1 APPLICATIONS AS RELAYS OR FOR AMPLIFICATION OF POWER

4.1.1 Remote Control

Thyratrons may be used readily as direct-acting on/off relays and call for no special comment beyond the fact that an alternating-current anode supply is preferable so that the grid is able automatically to regain control every cycle. The controlling voltage changes the grid potential from a negative value, well beyond the critical bias for the particular anode potential, to a zero or positive value. The bias may be either alternating or direct current. Fig. 11 is an example of such an on/off control; a switch could be substituted for the thermometer and a relay or contactor for the anode load.

4.1.2 Temperature Control

For small ovens, such as may be used for maintaining the temperature of oscillating crystals constant around, say, 50 degrees centigrade, the anode current of the thyratron may form the whole of the oven-heating current. Simple

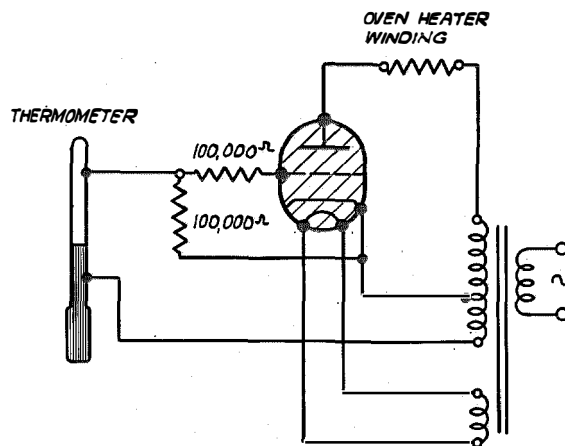

Fig. 11—Simple on/off temperature control.

on/off operation with a contact-making thermometer may control the grid voltage, reducing it to zero when the temperature falls and biasing well beyond the critical voltage when the temperature rises above the normal value. Alternating-current operation may be used throughout. Figure 11 shows this simple circuit, the accuracy of control being determined by the sensitivity of the thermometer.

For temperatures of 800 to 1200 degrees centigrade, such as are met in hydrogen and vacuum furnaces for treating valve parts, a constancy of about 10 degrees is sufficient and the circuit of

TABLE I  
APPLICATIONS OF THYRATRONS IN THE RADIO FIELD

General Class of Application	Examples of Application
(4.1) Relays, i.e., amplification of power.	(4.1.1) Remote control. (4.1.2) Temperature control. (4.1.3) Amplifiers with light-sensitive cells, e.g., measurement of power in a lamp load, switching on a beacon transmitter, power control on occurrence of a flashover. (4.1.4) Timed operations, e.g., delays on switching sequences. (4.1.5) Peak voltmeter, overmodulation indicator, and overload relay. (4.1.6) Frequency meter. (4.1.7) Frequency-responsive indicator or relay. (4.1.8) Direct-current amplifier.
(4.2) Instantaneous switches, i.e., control of power.	(4.2.1) Electronic switches, e.g., keying of transmitters, switching of cathode-ray oscillograph. (4.2.2) Pulse and oscillation generators, e.g., single and multiple pulses of square wave form, peaked-pulse generators, time bases for cathode-ray oscillographs and television, harmonic generators, frequency divider.
(4.3) Current and voltage regulators.	(4.2.3) Frequency comparator. (4.3.1) Generator output voltage control. (4.3.2) Variable-speed motors on alternating-current supply. (4.3.3) Torque amplifiers, e.g., remote operation of tuning devices, position-locating devices, synchronising of rotating machinery.
(4.4) Commutating devices.	(4.3.4) Alternating-current regulation, e.g., valve filament-heating control. (4.4.1) Motor commutators and inverters. (4.4.2) Rectifiers.

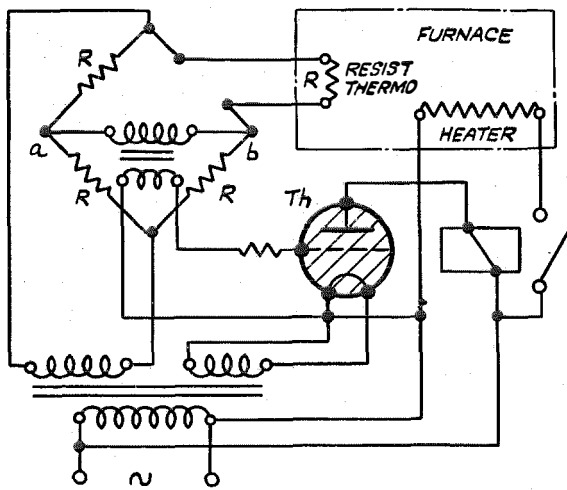

Fig. 12—High-temperature control.

Fig. 12 is used.<sup>5</sup> Here, a resistance thermometer forms one arm of an alternating-current Wheatstone bridge which is balanced for the normal temperature. A temperature change above normal produces an out-of-phase bias and one below normal an inphase bias on the grid resulting in anode current ceasing or flowing, respectively. Control of the normal temperature is obtained by variation in the resistance value of any one arm of the bridge. In the diagram, a small thyatron acts solely as a relay and operates a contactor for switching the main furnace current. A large thyatron could be employed to switch the furnace current directly in which case only half-cycle pulses of current will pass. Alternatively, if the heater current is beyond the capacity of the thyatron, this latter can be arranged to control a relatively small additional current sufficient to effect the temperature variation allowable, the main heating current to the furnace being controlled separately by a series resistance. Another way of controlling large currents, which can be adapted to furnace temperature regulation, is given in Section 4.3.4.

Extremely accurate temperature control can be effected by employing somewhat more elaborate circuits; it is possible to hold the temperature of an oil bath to within 0.005 degree centigrade over a period of some weeks.<sup>20</sup>

#### 4.1.3 Amplifiers with Light-Sensitive Cells

A very wide field of applications, covering all branches of industry and research, already exists

in the use of thyatrons and light-sensitive cells. In the radio field, applications are not so numerous, but the possibilities are indicated and methods of control are illustrated by three examples, viz., (a) switching on of beacon transmitters during hours of darkness or fog, (b) switching off a transmitter on occurrence of a flashover, and (c) estimation of power dissipated in a lamp load.

#### (a) Measurement of Power in a Lamp Load

The current output of a light-sensitive cell exposed to the illumination from the lamp load dissipating the radio-frequency power is indicated on a sensitive microammeter. The power may be determined by ammeter and voltmeter measurements of a direct or low-frequency alternating current required to produce the same illumination, as indicated by the meter.

The same principle is used when a thyatron is employed in conjunction with the light-sensitive cell. The circuit employed is that of Fig. 8(a), the light-sensitive cell taking the place of resistance  $R$ , as shown in Fig. 13. A decrease in the resistance of the cell, brought about by an increase in the intensity of the incident light, causes the anode current of the thyatron to increase progressively. The indicating meter, which is connected with a suitable load resistance in the anode circuit of the thyatron may have

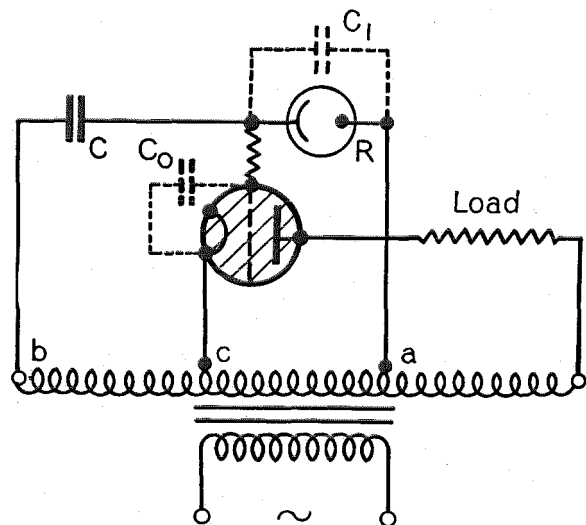

Fig. 13—Circuit for progressive increase of anode current with increase of illumination.



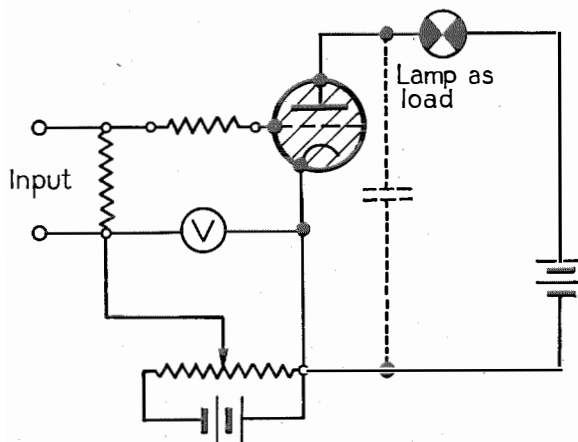

Fig. 16—Peak voltmeter.

tubes with filamentary cathodes are employed, a low-potential extension of the winding on the transformer may supply the bias voltage.

#### 4.1.4 Timed Operations

One useful circuit<sup>21</sup> for providing delays on switching sequences, etc., is given in Fig. 15 and forms a basis on which multiple time delays can be built up. The delay interval occurs from the instant of closing switch  $S$ , and its duration is controlled by the magnitude of  $R$  and  $C$  and the setting of the voltage divider  $P$ . In the diagram, an indirectly heated thyatron is employed and the heater voltage provides the bias supply.

With alternating voltage applied to  $L_1L_2$ , whenever the grid is positive, current will pass between the cathode and grid through the resistance  $R_x$  and condenser  $C$  will become negatively charged. When  $S$  is closed the cathode is connected to  $L_1$  and no alternating potential now exists between the grid and cathode. The full line voltage appears across the anode-cathode circuit. However, as the grid is negative by virtue of the charge on  $C$ , no anode current flows until this charge leaks away through  $R$  and finally brings the grid voltage to the critical value at which the arc strikes. Conduction continues until  $S$  is opened, thus cutting the anode circuit. The cycle may then be repeated. The time of charging, which determines the time that must elapse before the circuit can function again correctly, can be reduced to a few cycles by proper choice of  $C$ ,  $R$ ,  $R_x$ , and  $R_0$ .  $P$  is so con-

nected that when  $L_2$  is positive, end  $b$  is negative. Thus, movement of the slider towards  $b$  increases the negative component of alternating grid voltage so that the condenser  $C$  must discharge to a lower voltage before the critical potential is reached. Hence, movement of the slider towards  $b$  increases the time interval.

#### 4.1.5 Peak Voltmeter, Overmodulation Indicator, and Overload Relay

The circuit<sup>22</sup> (Fig. 16) is similar to that of the slide-back voltmeter utilizing hard valves. The peak value of the applied voltage is the difference between the grid bias just sufficient to stop conduction as measured by the voltmeter  $V$  and the critical bias, i.e., the bias at which the thyatron is just triggered, the applied impulses being absent. As distinct from the hard valve however, the thyatron anode current is either zero when the impulses are less than the predetermined amount or full value when they are greater, the value of anode current being determined by the (constant) load in the anode circuit. Indication that the tube has been triggered may be gauged from its characteristic glow, or a lamp may be used as the load. An obvious extension is the fitting of an alarm operated by the anode current. As a direct-current supply is used for the anode source, once the valve is triggered, current will continue until the anode circuit is opened.

To overcome the disadvantage of the circuit working once only until the anode supply is switched off, a condenser may be inserted,<sup>23</sup> as

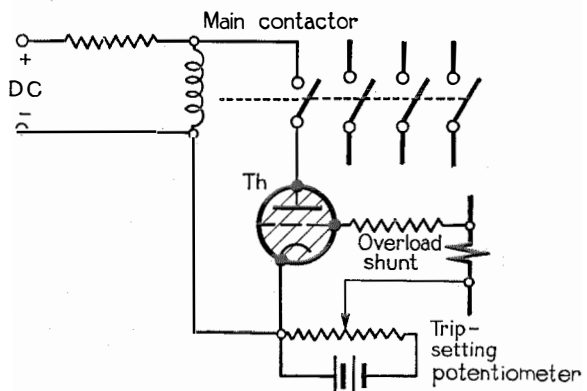

Fig. 17—Self-resetting overload relay.

shown dotted, so that the voltage falls periodically to zero (if the grid impulses render the valve conducting) as a result of the condenser discharging through the thyatron. A pair of headphones inserted in the negative return to the anode supply will produce a click each time the condenser discharges. The point at which the thyatron is first struck is indicated by a slow clicking; on one side there is silence and on the other the clicking merges rapidly into a buzzing sound. The critical potentials, with and without the applied input voltage, may then be readily determined without switching off the anode voltage.

In similar manner, peak values of current surges or currents which may be maintained for very short duration only may be indicated by the voltage across the resistance input. An extension of this circuit for use as an overload relay is evident. A convenient means of making the circuit self-resetting is to make the device operated by the thyatron also open the anode circuit and allow the grid to regain control. The thyatron may operate a relay in its anode circuit or it may act more directly, e.g., to trip the main contactor of an equipment by virtually forming a short-circuit across the operating coil, this contactor having the necessary auxiliary contacts to open the anode supply to the thyatron. A typical circuit is given in Fig. 17.\*

Since operation depends on the value of critical bias, a valve should be chosen in which this varies only slightly with temperature, or the air temperature around the thyatron should be maintained reasonably constant. If the applied voltage impulses have a much lower frequency of recurrence than the usual power-supply frequency, an alternating-current supply may be used on the anode and the circuit

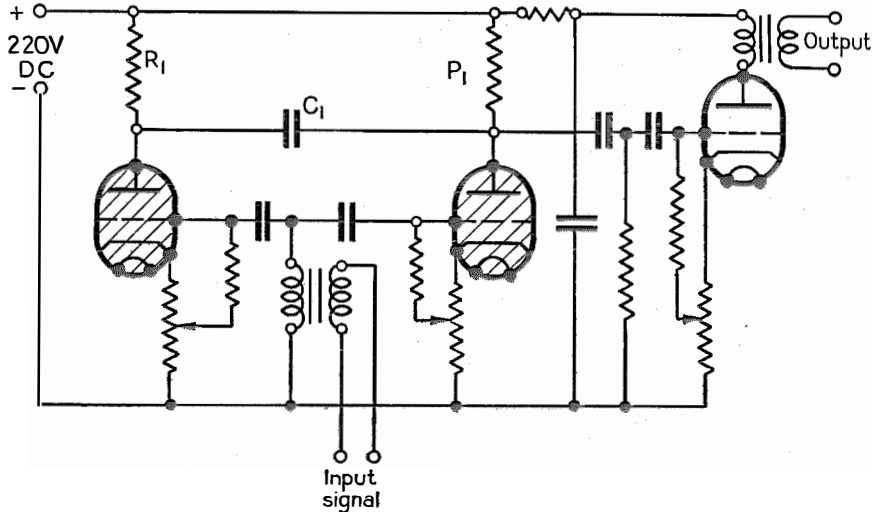

Fig. 18—Frequency meter.

becomes self-resetting. Repeated indications of voltages occurring in excess of the value predetermined by the setting of the potentiometer will then be given on, say, the lamp forming the anode load. This method is used in over-modulation indicators for monitoring modulated radio transmission.

#### 4.1.6 Frequency Meter

The basic direct-current stopping circuit of Fig. 10 may be driven by an alternating current and act as a frequency meter.<sup>25</sup> Whereas with ordinary meters the wave shape may have considerable influence on the indicated value, in this scheme the shape of the input wave is practically immaterial, its function being to release, alternately, two thyatrons which give constant output for operating the indicating meter.

The schematic is given in Fig. 18 from which it will be seen that the input wave is applied to both grids simultaneously and the two thyatrons are released alternately, one stopping the other through the intermediary of condenser  $C_1$ . Since the potential drop across anode and cathode jumps regularly (the frequency of the input voltage being constant) between the applied anode voltage and the normal valve drop, an alternating electromotive force is available having a constant wave form and amplitude and a frequency determined by the input signal. This electromotive force from one of the thyatrons

\* For a useful collection of thyatron relay circuits generally applicable in power engineering, see reference 24.



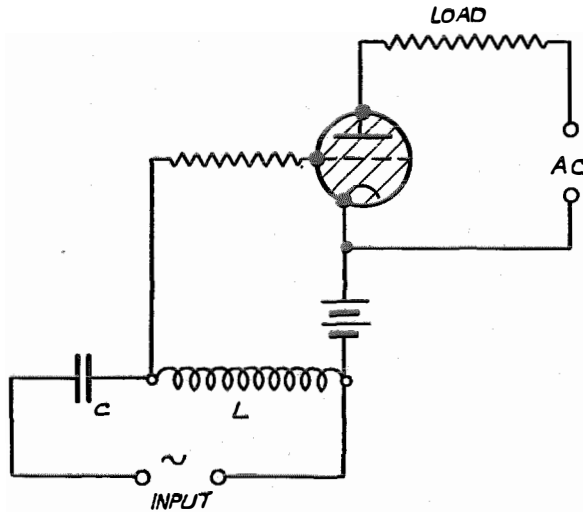

Fig. 19—Frequency-responsive circuit.

is amplified through a high-impedance alternating-current circuit, and applied to a meter for indication. A high-impedance circuit is used in order that the main thyatron circuits shall not be disturbed.

This circuit has been used satisfactorily with mercury-vapour valves up to 3,000 signals per second. If the signal consists of a group of waves of nearly equal magnitude and separated by a time interval greater than the resolution time, the circuit may respond to the separate peaks and not once to a group. Adjustments for this can be made in the selection of  $C_1$  and  $R_1$  and it is generally preferable at the higher speeds to reduce  $R_1$  rather than  $C_1$ , otherwise the extinction process becomes erratic.\*

A similar circuit, but one in which the output of both valves is rectified by a double-diode valve and the average rectified current read on the indicating meter, has been described.<sup>26</sup> Since

\* This remark applies in general whenever this type of direct-current stopping circuit is employed.

the magnitude of this current is proportional to the number of pulses delivered per second, it follows that the current is proportional to the input frequency. A linear relation up to 7,000 cycles per second was obtained.

#### 4.1.7 Frequency-Responsive Indicator or Relay

To perform some relay or indicating operation, which shall function at a certain frequency only, the circuit of Fig. 19 may be used. The elements  $LC$  (here shown in series connection, but for some applications a parallel circuit may be used) form a resonant circuit. At the resonant frequency, the voltage across  $L$  is large and the circuit operates. At other frequencies, only a small voltage exists across  $L$  and the thyatron passes no current. Such a circuit is useful, for example, when switching operations are to be performed during acceleration of alternators or motors where the electrical frequency is critically related to the rotational speed. Use has also been made of this scheme in carrier-current operation.

#### 4.1.8 Direct-Current Amplifier

By using a vacuum valve as a phase-shifting input device for a thyatron, reasonably linear amplification can be obtained and Turner<sup>27</sup> constructed a unit which could be used either as an amplifier or relay. The basic circuit is given in

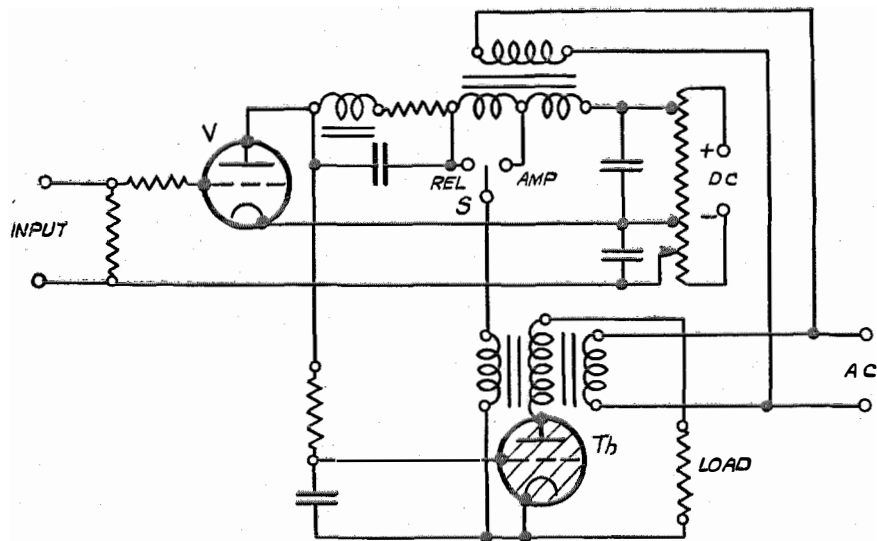

Fig. 20—Direct-current amplifier, basic circuit (Turner).

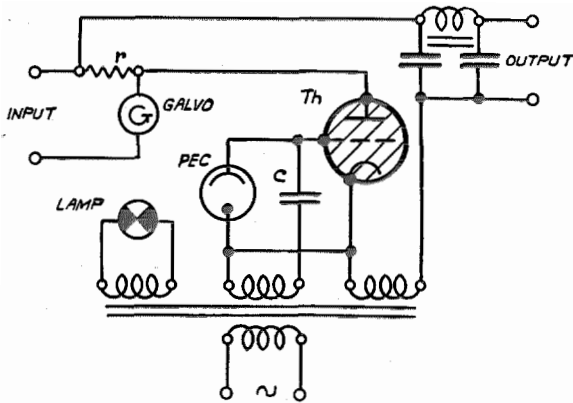

Fig. 21—Direct-current amplifier, basic circuit (Steghart).

Fig. 20 but reference to the original paper should be made for values of components and variations of the circuit.

The input valve *V* is operated on the curvilinear part of its characteristic, and hence changes its internal resistance with any change of grid voltage. Superposed on its direct-current anode supply is an alternating voltage at mains frequency. The circuit contains a choke in series with the anode resistance of the input valve which is the variable element. A voltage is obtained from the combination of inductance and resistance which differs in phase from the alternating-current supply voltage by an amount depending on the value of the resistance, and hence on the input voltage. This voltage is applied to the grid of a thyatron, the anode of which is supplied from the same alternating-current source as the input valve. One connection of the switch *S* gives a phase advance (from the out-of-phase position) and hence gradual control of the anode current of the thyatron, for amplifier action. The other connection retards the phase and gives a sudden change in anode current for relay action. Compensation for the sudden changes in voltages which occur when the thyatron strikes is obtained by providing an additional voltage from the thyatron anode alternating-current supply to its grid circuit.

Extension of the circuit to control large powers is possible by substituting a transformer for the load of Fig. 20 and applying the voltage therefrom to other thyratrons which will deliver half sine waves of output current.

A very stable direct-current amplifier<sup>28</sup> utilizing a photoelectric cell as the phase-controlling element is given in Fig. 21. The input voltage operates a galvanometer to control the amount of light falling on the cell. The output current from the thyatron passes through the resistance *r*, which is in series with the direct-current input, and produces a voltage in opposition to the input voltage. When a balance is obtained, no further deflection of the galvanometer takes place. By this means the output current is proportional to the input voltage. A typical setup gives an output of 3 watts (30 milliamperes, 100 volts) for an input of 18 millivolts and, when operated by current, a similar output is obtained for an input of 0.01 microampere.

#### 4.2 APPLICATIONS AS INSTANTANEOUS SWITCHES OR FOR CONTROL OF POWER

##### 4.2.1 Electronic Switches

Electronic switches are used, for example, in keying transmitters for telegraph operation and in switching cathode-ray oscillographs and oscilloscopes to record more than one phenomenon at a time.

##### (a) Transmitter Keying

For a keying system to be universally applicable to any amplifier and not affect the

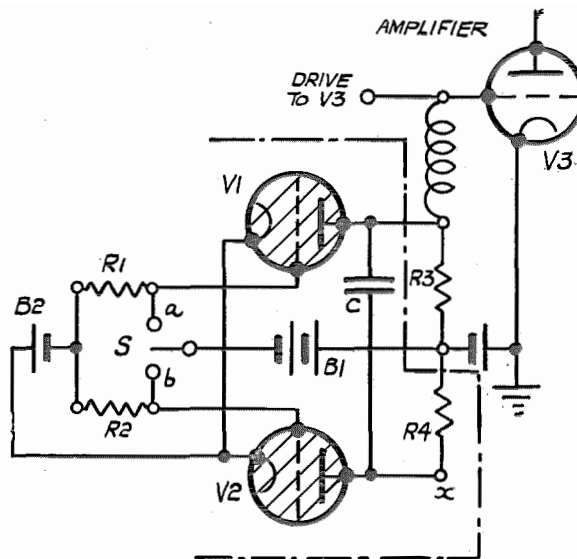

Fig. 22—Keying of transmitter.

normal biasing arrangements, the keying voltage should be directly connected to the grid of the valve which is to be "blocked." A suitable circuit for this<sup>29</sup> is given in Fig. 22. The amplifying valve  $V_3$  is biased for normal operation partly by the supply  $B$  and partly by the voltage developed across  $R_3$  if grid current is flowing. During the spacing periods,  $S$  is connected to  $a$  and the keying thyatron  $V_1$  passes current, so connecting the source of negative potential  $B_1$  directly to the grid of  $V_3$  and "blocking" it. When  $S$  is moved to  $b$ , for the marking period, thyatron  $V_2$  is released and applies a negative impulse to  $V_1$  through condenser  $C_1$  which was charged to the potential difference across  $R_3$ , as already explained for the basic direct-current stopping circuit of Fig. 10.  $V_1$  is then inactive,  $V_2$  passes current, and the amplifier valve  $V_3$  is biased for normal operation. On switching to the spacing condition,  $V_1$  extinguishes  $V_2$  and thus instantaneous change-over is assured.

The time of change-over is independent of the characteristics of the key for current will continue to pass in whichever thyatron is conductive until the release of the other thyatron causes the current to cease. In place of the key, a voltage of the correct sign and magnitude may be applied from some other low-power keying system to control the thyatron grids. The grid current of  $V_3$  flowing through  $R_3$  is entirely without effect on the operation of the keying unit. Whilst keying on the control grid of  $V_3$  is shown, the system is equally applicable to keying on the screen grid of a tetrode or pentode valve.

Two amplifiers may be keyed in complementary fashion with instantaneous change-over, e.g., one amplifier being in the marking condition whilst the other is spacing. To do this, point  $x$  of  $R_4$  is suitably connected to the grid of the second amplifier and  $V_2$  acts as its keying valve.

### (b) Switching for Cathode-Ray Oscillograph

For obtaining traces of two independent voltages on a cathode-ray oscillograph, the circuit of Fig. 23 forms a useful switching system.<sup>30</sup> The two voltages are switched alternately to the  $P_y$  plates during the flyback period of the time base, so that each event occupies the time of one sweep of the linear time base (which latter is also incorporated in the unit). On a cathode-ray oscilloscope the persistence of vision and after-glow of the screen material enable both traces to be seen simultaneously whilst the conditions are obvious in an oscillograph.

Pentode  $V_1$ , condenser  $C_1$ , and thyatron  $V_2$ , form a linear time base, as will be described in section 4.2.2(c). Synchronising signals may be supplied to transformer  $T_1$ , if desired. Thyatrons  $V_7$  and  $V_8$  are biased negatively by battery  $B_2$  and do not strike until the time base is in operation, when the discharge of  $C_1$  through  $V_2$  (producing the flyback stroke) causes the anode potential of  $V_2$  to fall. This change of potential is fed to the grid of the tripping valve  $V_4$  causing a decrease of anode current therein. The grids of  $V_7$  and  $V_8$  are connected to  $V_4$ , via  $C_4$ , and the rise of potential occasioned by the flyback makes the grids sufficiently positive for ignition to occur. When thyatron  $V_7$  fires, its anode current is limited by resistances  $R_{14}$  and  $R_{11}$ .  $R_{11}$  is of such value that when  $V_7$  conducts, valve  $V_6$  is biased well beyond cutoff. At the succeeding flyback stroke,  $V_8$  fires and  $V_7$  ceases

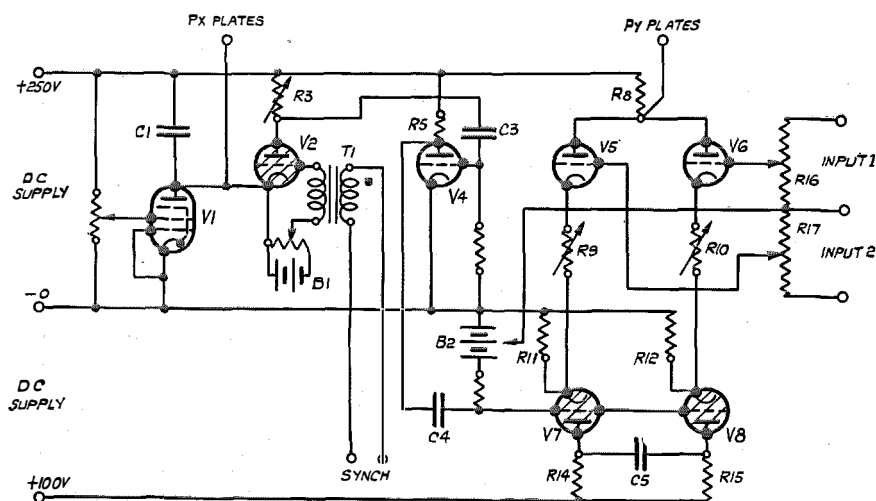

Fig. 23—Cathode-ray-oscillograph changeover switch and base time.

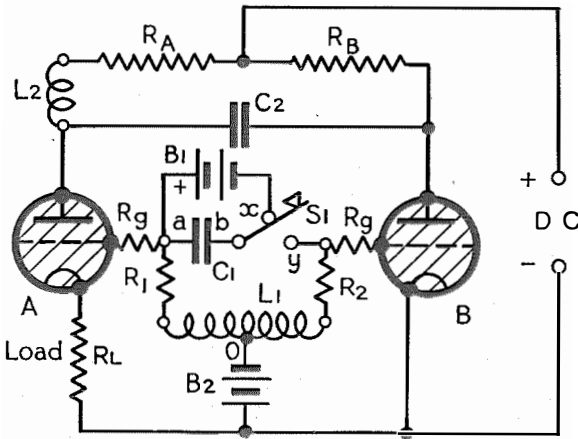

Fig. 24—Generator of square-wave single pulses.

to conduct by the action of the commutating condenser  $C_5$ .  $V_6$  is then biased beyond cut-off and  $V_5$  receives its normal working bias from  $B_2$  and cathode resistors  $R_9$  and  $R_{11}$ . Thus, during each timing stroke one amplifying valve has cut-off bias and the other working bias whilst the conditions are reversed at each flyback stroke.

Input potentiometers  $R_{16}$ ,  $R_{17}$ , connected to the circuits under examination, apply suitable voltages to the grids of  $V_5$  and  $V_6$ , which act as amplifiers and have a common load  $R_8$  connected to the  $P_y$  plates of the oscillograph. The cathode resistors  $R_9$  and  $R_{10}$  are variable to permit adjustment for coincidence of the zero lines of the separate traces. The normal shift voltage dividers are provided for the X and Y plates but are omitted from Fig. 23.

The traces are quite steady on the screen and a photograph of 90 seconds duration showed not the slightest evidence of blurring. For visual observation, the flicker is not apparent if the time base is not used at too slow a rate.

4.2.2 Pulse and Oscillation Generators

(a) Single- and Multiple-Pulse Square-Wave-Form Generator

A square-wave single-pulse generator<sup>31</sup> or heavy-duty time switch is given in Fig. 24. It was originally developed for research on thermionic emission of oxide-coated cathodes where the anode potential for measuring emission could be applied for only very brief duration. It may

be used to switch a direct current for an accurately determined period of time without distortion of the wave form in the switching device. The generator is capable of being used over a very wide range of current values. Among others, such applications as testing overload relays and fuses are apparent.

The basic direct-current stopping circuit is used, thyatron  $A$  being the switching valve and rated accordingly, whilst  $B$  acts to stop current flow in  $A$  after the predetermined time interval has elapsed.  $R_L$  represents the load. The timing of the passage of current is entirely electrical, and hence very constant. It is determined by the damped oscillatory circuit  $L_1C_1R_1R_2$ . With spring key  $S_1$  in position  $x$ , condenser  $C_1$  is charged to the potential of the supply  $B_1$ , the plate  $a$  being positive. The two thyratrons are biased by  $B_2$  so that no current flows. When  $S_1$  is depressed to  $y$ ,  $C_1$  is connected in parallel with  $L_1$ , and valve  $A$  is immediately released by the positive voltage between  $a$  and  $o$  bringing its bias below the critical value whilst, at the same time, the bias of  $B$  is made more negative. After approximately one-quarter period of the oscillation, plate  $b$  of condenser  $C_1$  becomes positive and

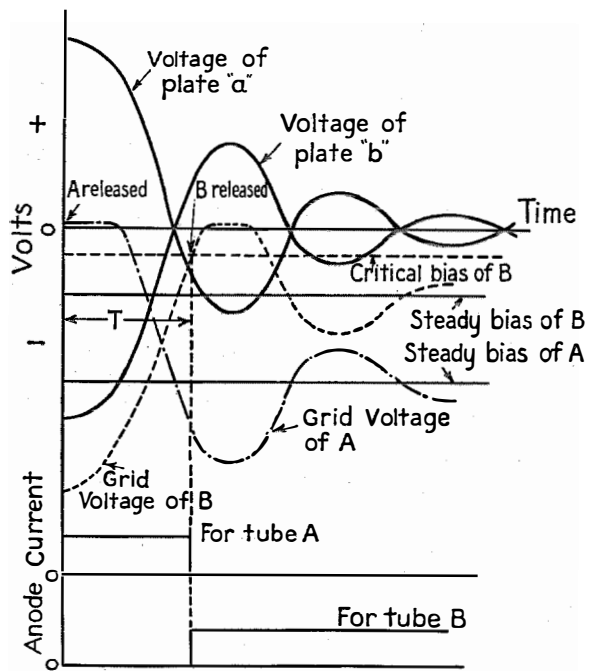

Fig. 25—Wave forms in circuit of Fig. 24.

hence thyatron *B* is released thus stopping *A* through the intermediary of condenser  $C_2$  in the manner already described. The damping of the circuit, controlled by the resistances  $R_1$  and  $R_2$ , can be adjusted so that the grid of *A* is not again brought below the critical bias and only one pulse of current passes through *A*. *B* will continue to conduct until its anode supply is switched off. Key  $S_1$  is of the spring type and is held depressed only until the current pulse has passed through *A*. On release, it again allows condenser  $C_1$  to be charged for further use. The voltage relations existing in the grid timing circuit are shown in Fig. 25.

As a result of the charge and discharge current of condenser  $C_2$ , the wave shapes of the currents in  $R_A$  and  $R_L$  are different. Thus, if  $L_2$  is not present and  $R_A$ ,  $R_B$ , and  $R_L$  are resistive, the wave shape of the current in  $R_A$  is as shown in Fig. 26(a), the exponential "tail" being caused by the discharge and charge in the reverse direction of  $C_2$ , this current flowing through *B* and the direct-current supply. In  $R_L$ , the wave shape is as in Fig. 26(b), the top peak being caused by the charging current of  $C_2$ , which flows through  $R_B$ , *A*, and the direct-current source. Insertion of the choke  $L_2$  delays the growth of the current in  $R_A$  at "make" in opposite sense and equal magnitude to the condenser-charging current and a square-wave pulse of current in the load  $R_L$  results. It is for this reason that the load is placed in the cathode lead of thyatron *A*, resistance  $R_A$  being provided only for the purpose of obtaining a potential to which  $C_2$  is charged. To obtain the desired condition, the component values must be related by  $R_A = R_B$  and  $L_2 = C_2 R_A^2$ .

Times of current flow between 1 and 20 milliseconds were obtainable with an air-cored inductance  $L_1$  of 20 henries and capacitances for  $C_2$  varying from 0.02 to 8.0 microfarads. Time intervals up to 20 seconds are possible by charg-

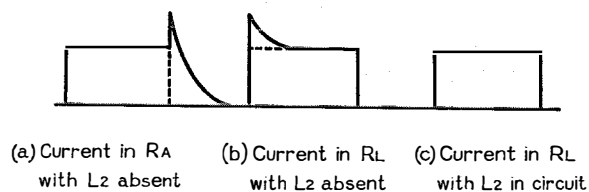

Fig. 26—Current wave forms in circuit of Fig. 24.

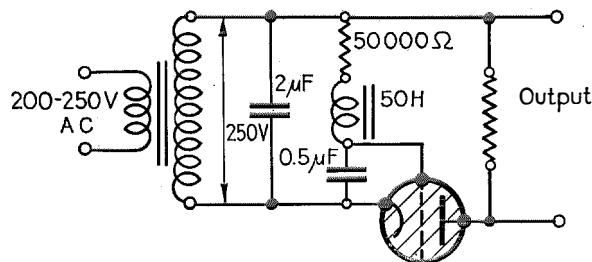

Fig. 27—Thyatron pulse generator.

ing a condenser and discharging it suddenly through a neon lamp or an additional thyatron.

These remarks on the current wave shapes apply not only to this particular application but whenever this direct-current stopping circuit is used. Although the exact wave shape is immaterial in many applications, in others account may have to be taken of this and compensation applied as indicated.

If the grid circuit is driven by an alternating voltage in place of the oscillatory circuit, square-wave pulses occurring at regular frequency and of duration equal to a half period of the driving frequency may be obtained. See Section 4.4.1 and reference 32.

#### (b) Peaked-Pulse Generators

For investigations on the ionosphere, in altitude meters, radio location devices, etc., a very peaked pulse of short duration (1 to 100 microseconds) is necessary to permit accurate measurements between corresponding points of transmitted and received pulses. The ideal shape would have a vertical wave front. In practice this is difficult to obtain and the usual type is of triangular form with very steep sides, measurements being made to the apex of the triangle.

When the recurrent frequency is that of the alternating-current mains supply, a thyatron operated so that ignition occurs at the peak value of the anode alternating voltage, gives a useful and stable means of producing such pulses. A suitable circuit<sup>33</sup> is shown in Fig. 27. The output voltage, of the shape of Fig. 28(a), is modified by the addition of a condenser and resistance as in (b) or by a series circuit, approximately critically damped, which gives the form

of (c). Such pulses are often used to control a "squegger" oscillator, the thyatron initiating the oscillation and the oscillator itself determining the instant of cessation. The voltage from the trigger circuit may be applied in series with the bias to the "squegger" oscillator valve. If alternating-current is applied to the anode, operation will occur only at the peak of the alternating-current wave because of the setting of the thyatron release. If direct current is used, a series modulator valve may be inserted in the high-tension lead to the oscillator valve, the modulator being controlled by the trigger circuit.

The high-voltage thyratrons now available may be connected as a switch directly in the high-tension lead to an oscillator or amplifier valve so that current flows only when the thyatron is conducting. This is far more efficient than the modulator valve referred to above, the voltage drop across the thyatron being negligible. A simplified circuit is shown in Fig. 29 in which the thyatron *Th* is triggered by a pulse generator (Fig. 27). The frequency of recurrence is not necessarily the mains frequency. Condenser *C*, Fig. 29, charged to the value of the

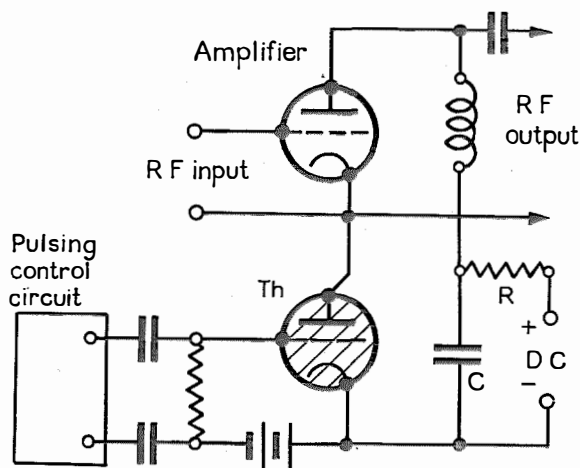

Fig. 29—Series control of high-tension supply in pulse amplifier.

direct-current supply, is discharged rapidly through the amplifier valve and thyatron in series. Its voltage falls below the ionisation potential of the thyatron (see Section 4.2.2(c)) and conduction ceases. The pulse width is determined by the rate of discharge of *C*, which is a function of resistance of the amplifier valve. *R* and *C* are chosen to allow *C* to charge during periods of non-conduction.

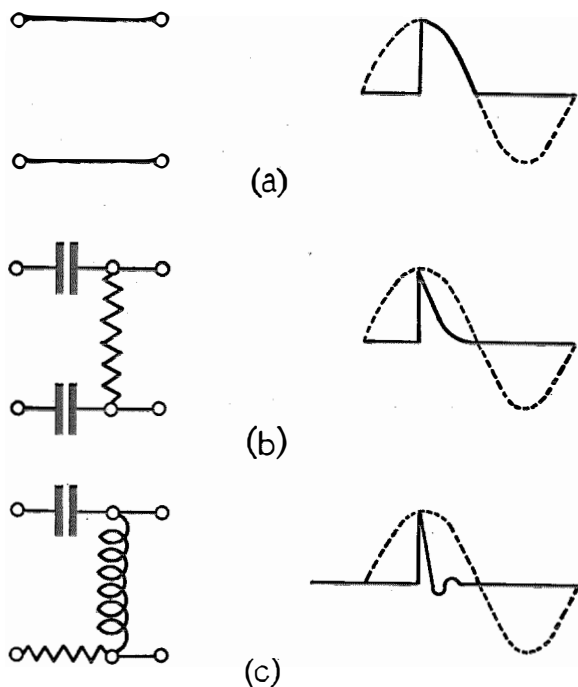

Fig. 28—Wave form in generator of Fig. 27 and modifications.

(c) *Relaxation Oscillators*

The thyatron has a great advantage over neon tubes when applied to relaxation oscillators. It provides a much greater voltage range between the extinction and starting of the arc, the latter being under control of the grid bias. If the charging resistance is replaced by a pentode, which acts to maintain the charging current constant, a linear relation between time and condenser potential may be obtained with a "flyback" time so short as generally to be invisible on the screen of a cathode-ray tube. It is thus well suited for use as a linear time base.

Investigation of a thyatron for this purpose was made in 1932 by Reich,<sup>34</sup> and has been further investigated recently by Puckle.<sup>35</sup> Both found that the limit of frequency of oscillation is not set entirely by the deionisation time of the valve but by the necessity of reducing the charging current as the capacitance is reduced to obtain extinction of the discharge.

A typical self-operating time-base circuit is shown in Fig. 30. The pentode  $V_2$ , operated above the knee of the anode-voltage–anode-current characteristic,\* acts to maintain constant the charging current from the direct-current supply to condenser  $C_1$ . The voltage across  $C_1$ , determined by the grid bias on thyatron  $V_1$ , will eventually reach a value that discharges the thyatron.  $C_1$  is rapidly and almost completely discharged, and the voltage falls below the ionisation potential of  $V_1$ . Charging of the condenser then recommences.  $R_1$  limits the discharge current of  $C_1$  to a value within the emission capabilities of the thyatron. The bias on the grid of the thyatron determines, principally, the voltage amplitude of the time-base sweep.

A synchronising signal, occurring at predetermined time intervals, may be applied to the grid of  $V_1$ , to alter the anode potential at which the valve strikes. A steep wave front of such a signal will increase the precision of timing. If the synchronising signal is of sinusoidal form, the discharge must occur at exactly the same value of anode voltage in each successive cycle. In general, this can occur only if the period of the synchronising signal is equal to, or is some integral multiple of, the period of the relaxation oscillation. Fig. 31(a) shows the condition when the synchronising signal is too low in frequency; synchronisation cannot be obtained as the thyatron does not fire at similar points of the synchronising cycle. Fig. 31(b) shows the correct condition in which synchronising and time-base signals are of equal periodicity. In Fig. 31(c) the synchronising signal is a multiple of the time-base recurrence frequency. Similar conclusions have been reached by Builder and Roberts<sup>36</sup> and independently by Guljaev.<sup>37</sup>

A simple means of stabilising such an oscillator<sup>38</sup> and making it

\* A saturated diode may also be used, the value of resistance being controlled by the cathode temperature of the diode.

more independent of changes of ignition potential resulting, for example, from temperature changes, is to connect a resistance  $R_3$  between the anode and grid of the thyatron, as shown dotted in Fig. 30. The grid potential of  $V_1$  is then dependent on its anode-cathode potential. By increasing the value of both  $R_2$  and the bias  $B_1$ , the frequencies generated by two valves of widely differing characteristics which originally were 500 and 850 cycles per second, were brought to within a few percent of a common value around 650 cycles per second. Also, the circuit is more stable as regards spurious voltages, such as at  $A$  in Fig. 32,<sup>†</sup> which would normally fire the thyatron. In this case when the condenser discharges, the grid assumes the large negative value of  $B_1$  and approaches the critical bias only near the point where the synchronising pulse is applied. Further, this large negative bias clears the positive ions more rapidly and permits operation at higher frequencies.

For a velocity-modulated television system,<sup>39</sup> a velocity-modulated time base is required. This differs from an unmodulated one only in that the charging pentode has the video signal applied to its grid so that the rate of charge of the condenser is dependent on the instantaneous value of the light falling on the light-sensitive device. The video signal is inserted between  $x$  and  $y$  of Fig. 30.

By utilising a specially constructed thyatron and introducing feedback into the oscillator circuit from the charging pentode, it has been

† The diagram cited is with a resistance in place of the pentode  $V_2$  and hence does not give a linear trace.

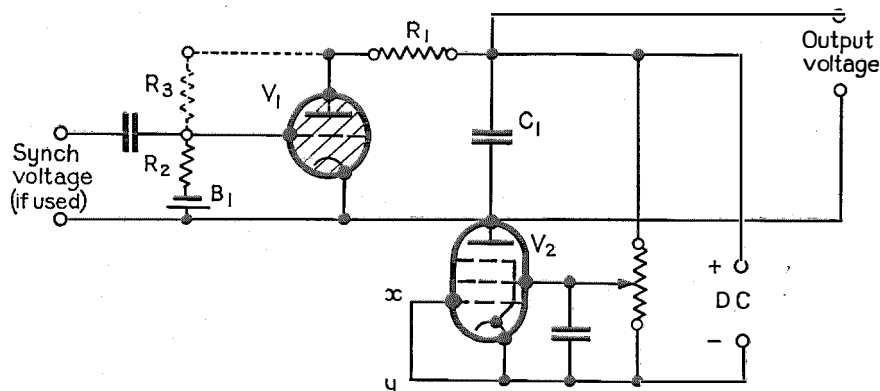

Fig. 30—Relaxation oscillator, for time base.

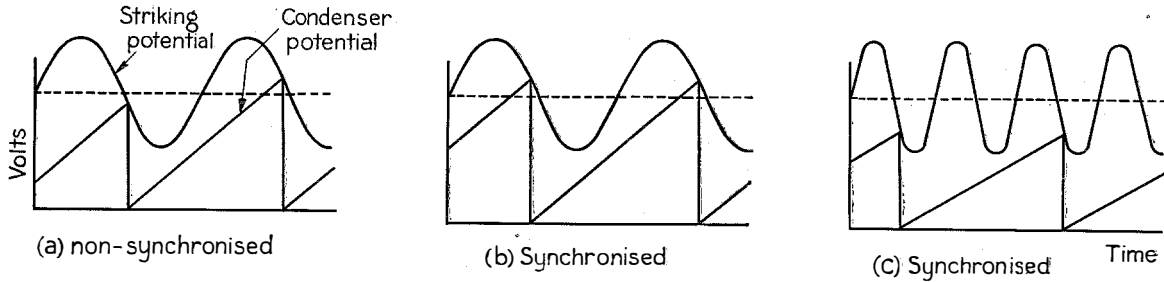

Fig. 31—Voltages in sinusoidally synchronised time base.

possible to obtain<sup>40</sup> a sensibly linear time base with a recurrence frequency of 1 megacycle per second.

(d) Harmonic Generators

The wave front of the current passing through a thyatron can be made extremely steep, either by allowing the valve to switch a direct-current supply through a substantially resistive circuit, by discharging a condenser, or by delaying the point of firing when using an alternating anode supply, and the output voltage will be rich in harmonics of the repetition frequency.

The circuits of Figs. 24, 27, and 30 are useful as harmonic generators. The grid circuit is driven at the fundamental frequency and the output voltage, usually developed across a resistance, may be fed to frequency-selective circuits. If the ratio of reactive volt-amperes to watts be high enough in such tuned circuits, a sinusoidal voltage at the desired frequency may be obtained, said circuits being maintained in oscillation by the impulses of harmonic current passed by the thyatron.

By employing a fundamental alternating voltage having a frequency of several kilocycles per second, in place of the usual direct voltage, Kersta<sup>41</sup> has obtained harmonics of high order. With a fundamental frequency of 66 kilocycles per second, a flat distribution of harmonics up to 3.5 megacycles per second, and quite useful outputs even to 25 megacycles per second are obtainable.

(e) Frequency Divider

Among the best known applications of frequency division are those in frequency-measuring

equipment and the generation of carrier frequencies for wire-line carrier systems.

The relaxation oscillator offers a basis of design. Builder<sup>42</sup> has discussed the frequency stabilisation by selective feedback and synchronisation of such an oscillator operated as a frequency divider at high orders of division. A basic circuit is given in Fig. 33 in which the functions of relaxation, selection, and feedback are substantially independent. A circuit more economical in components is described in the paper. The oscillator is of the simple type already discussed in Section 4.2.2(c) in which the natural frequency is determined by the time constant of  $RC$ , the anode voltage, and the cathode bias developed across  $R_3$ .  $R_1$  limits the discharge current of  $C$ , and  $R_2$  has a high value (0.25 megohm) to prevent the grid of the thyatron  $V_1$  from attaining any substantial positive value.

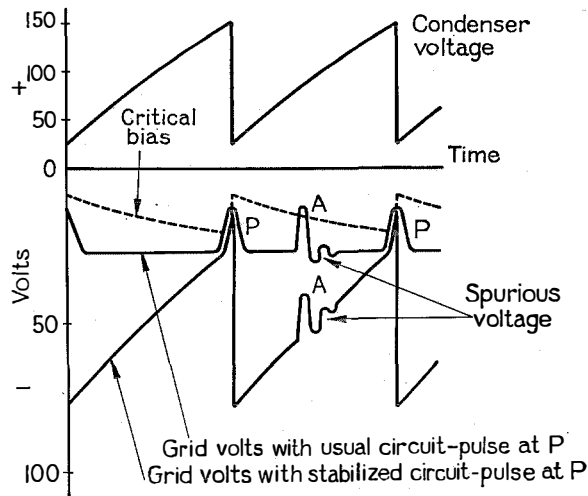

Fig. 32—Stabilised sweep-circuit oscillator voltages.



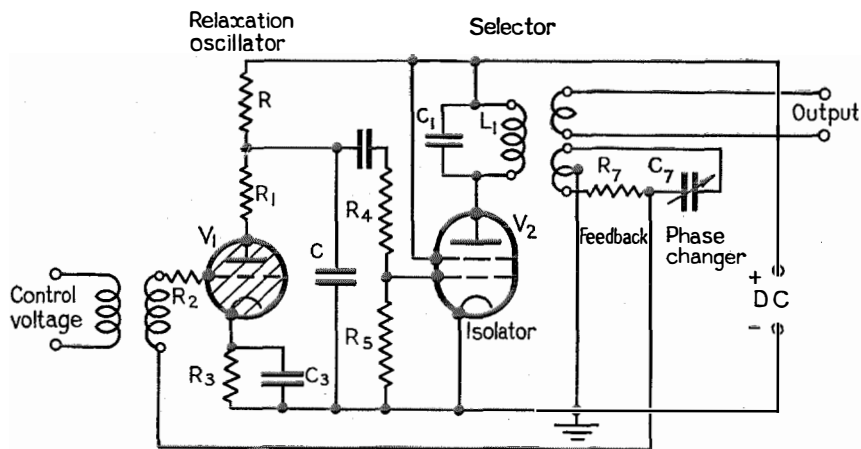

Fig. 33—Frequency divider (Builder).

The selector circuit  $L_1C_1$ , tuned to the frequency to be generated, is fed from the oscillator via the isolating valve  $V_2$ . Secondary windings on  $L_1$  provide both output and feedback voltages.  $C_7$  and  $R_7$  act as a phase changer for the feedback voltage as previously described.

Fig. 34 gives the wave forms of the voltages, in which  $e_s$ , the voltage across the tuned circuit, is substantially sinusoidal. A voltage proportional to this is fed back to the grid circuit of the oscillator.  $e_c$  is the actual grid voltage of  $V_1$ , being a combination of the feedback and cathode bias voltages. The grid voltage  $e_c$  does not rise appreciably above zero because of the resistance  $R_2$  and during the greater part of the positive half cycles of the feedback voltage, the thyatron is conducting and the anode is at the ionisation potential. As soon as the grid voltage  $e_c$  becomes negative, anode current ceases as condenser  $C$  extinguishes the arc. Condenser  $C$  then charges until the grid potential rises towards zero and the arc is struck again. A saw-tooth wave form  $e_a$  results and alternates with periods of about equal length during which the voltage is zero. The instant of striking is precisely determined by the simultaneous rise of anode and grid voltages. Curve  $e_a$  also gives the form and phase of the potential applied to the isolator valve and, for equilibrium, the fundamental component of  $e_a$  must be in exact antiphase with the voltage  $e_s$ ; the phase shifter provides for this. A control voltage may be inserted as shown and frequency division by factors up to 10/1 is readily possible.

Another circuit, operating in a somewhat different manner<sup>43</sup> and entirely on alternating current, is given in Fig. 35. When the phase angle of the voltage induced in the grid circuit is adjusted to a suitable value by means of the phase shifter, the arc will start and the anode current will charge condenser  $C$  until the potential across it approaches the supply voltage. The arc then ceases and the condenser discharges through  $R$  until the

drop in potential allows the thyatron to conduct again. By making the product of  $CR$  large, the starting of the discharge may be delayed several complete cycles, and by properly choosing the phase angle, the current can be reduced to short pulses of about 100 milliamperes every third or fourth wave as shown in the diagram. With controlled-frequency mains, the circuit can be used to obtain time markings or as a stroboscope with a discharge tube connected across the output terminals.

#### 4.2.3 Frequency Comparator

To check the frequency of an oscillator against a standard so that comparisons are given at closely spaced periods of time is not easy, but a circuit recently developed<sup>44</sup> provides for this. An elementary schematic to illustrate the principles is shown in Fig. 36. The two oscillators,  $O_1$  and  $O_2$ , are adjusted to differ by 1/10th cycle per second. The output voltages are combined in the hybrid coil and amplified and rectified to control the firing of thyatron  $V$  once each beat cycle.

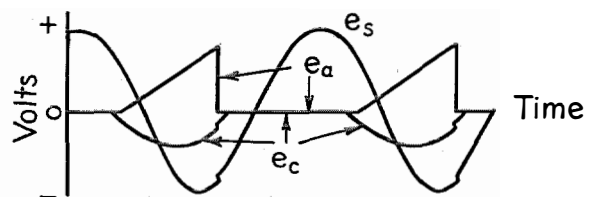

Fig. 34—Wave forms in circuit of Fig. 33.

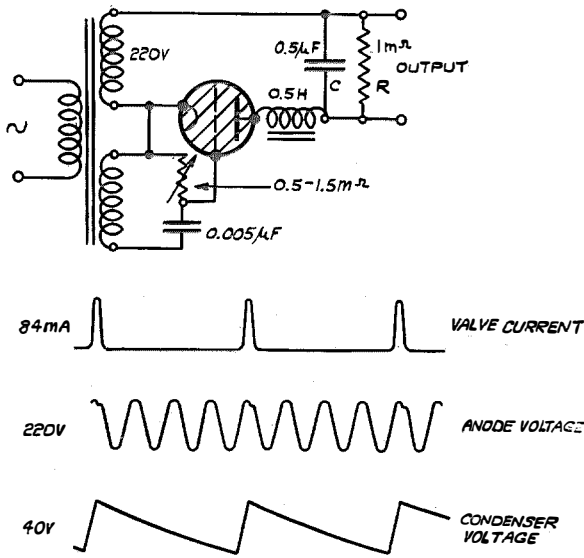

Fig. 35—Frequency divider (Kluge).

The charged condenser  $C$  is discharged through  $V$  and the spark coil  $T$  causing a brief flash of light in the mercury discharge tube  $G$ . This illuminates the translucent scale  $S$  driven from a frequency standard.  $S$  is suitably engraved and gives an indication of time, which is recorded photographically on the slowly moving film so that images of the scale from successive flashes are just separated. Thus the time elapsed during a single 10-second beat cycle is recorded to the nearest 1/1000th second and any irregularity in the beat pulses is only 1/(10 × 100,000) of the frequency of either 100-kilocycle-per-second

oscillator, the precision of comparison between oscillators is 1 part in  $10^{10}$ .

To ensure accuracy, the thyatron must fire abruptly at the same part of each cycle. Fig. 37 represents a vector diagram of the voltages at the input of the measuring circuit. As  $E_1$  rotates at the beat frequency with respect to  $E_2$ , the vector  $(E_1 + E_2)$  varies in length over the beat cycle. This vector is amplified and rectified to provide a negative bias on the thyatron grid. The valve fires when the voltage falls below the critical value represented by circle  $c$ . If the point of entry is  $a$  (i.e., voltages equal), the firing will be earlier than if the voltages are slightly different and barely graze the circle at  $b$  or  $b'$ . The possible error is thus approximately determined by the ratio of the radius of  $c$  to the circumference of the circle swept by  $E_1$ , and the error is made small by amplifying  $(E_1 + E_2)$ , thus increasing the sensitivity or effectively reducing  $c$ . When the voltages are thus critically compared, their amplitudes must be almost identical or no record is obtained, but if the thyatron fires at all it does so at a time known within exact limits. The value chosen was 65 decibels larger than the critical value of the sum required

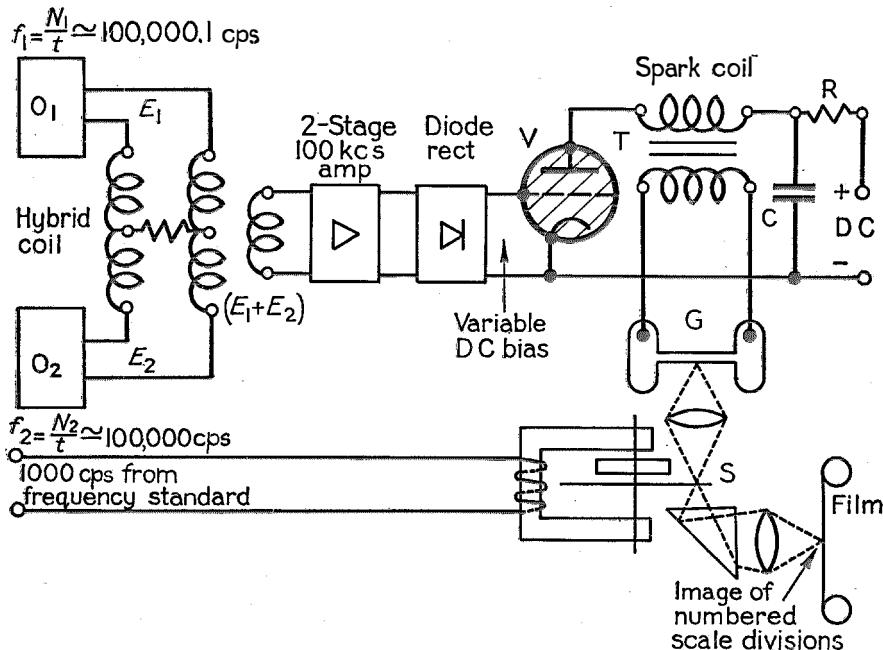

Fig. 36—Circuit for measuring short-time stabilities of oscillators.

to fire the thyatron and thus the voltages had to be alike in amplitude within about 0.05 per cent.

#### 4.3 APPLICATIONS AS CURRENT AND VOLTAGE REGULATORS

##### 4.3.1 Generator Output Voltage Control

Thyatron voltage regulators offer several advantages over mechanical types, particularly in the elimination of all moving parts and contacts and in the speed of response which is very high and is, in fact, not limited by the thyatrons but by the auxiliary circuit elements often used. Another advantage is the ease with which an antihunting force may be introduced into the system.

The primary controlling element in such regulators is a Wheatstone bridge, of which two opposite arms are constant resistances and the other two of resistances which have nonlinear voltage-current characteristics, such as tungsten- or carbon-filament lamps, semi-conductors (such as silicon carbide\*), valves operating at saturated emission, etc. Silicon carbide has the great merit of giving an instantaneous change of resistance with change of applied voltage. Where such high-speed response is not required, tungsten-filament lamps are readily available at low cost and give good results. As they are operated at half the rated voltage, they remain virtually constant in resistance value and the life can be considered as almost indefinite.

\* Marketed under such trade names as "Thyrite," "Metrosil," etc.

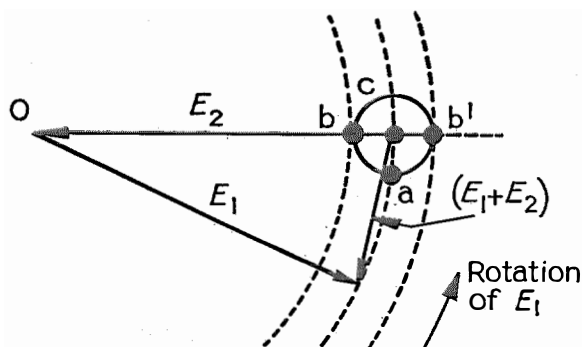

Fig. 37—Vector diagram of voltages in circuit of Fig. 36.

It is interesting to note that, in the past, it has been considered necessary for prime movers employed with transmitters utilising final-stage Class B anode modulation, in which the load varies with the depth of modulation, to have extra-heavy flywheels to avoid cyclic variations. Recently, however, the reverse has been tried. The inertia of the moving parts has been decreased and the speed allowed to vary with the load fluctuations. The output voltage is held constant by a high-speed thyatron voltage regulator. Such an arrangement would not be possible with mechanical types of regulator as the response is too slow.

One circuit<sup>5</sup> used for the control of an alternating-current generator is given in Fig. 38 in which  $R_1$  and  $R_2$  are, respectively, the ohmic and nonlinear resistances of the bridge, which is consequently balanced for only one voltage. Under these conditions, no voltage is applied via  $T_1$  to the grids of the thyatrons  $V_1$  and  $V_2$ , and no discharge occurs. Unbalance of the bridge, as a result of a change in generator output voltage, causes one or the other of the thyatrons to pass current and oppose or add to the field current of the generator, thus restoring the output voltage to normal. As shown, the anode supply for the thyatrons is taken from the alternating-current output of the generator and the thyatrons rectify this and feed direct current into the field circuit. The thyatrons in this case operate only when the bridge is out of balance.

For heavier, three-phase machines, a similar circuit to that used for direct-current generator control is preferable. In this case the variable direct-current controlling bias is obtained by rectification of the alternating-current generator voltage before application to the bridge. Each phase voltage may be rectified separately and the three direct voltages added together to give a resultant which is proportional to the arithmetical sum of the three phase voltages. Generators of 20,000 kilowatts have been so controlled<sup>45</sup> and excitation currents as high as 600 amperes\* obtained wholly from thyatrons.

\* From a 6-valve rectifier, each thyatron being rated at 100 amperes average, 600 amperes peak anode current, and 1,500 volts inverse voltage.

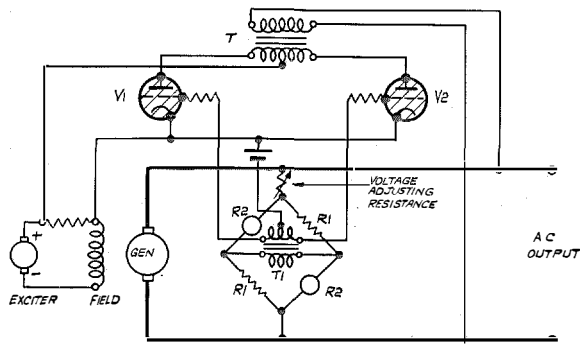

Fig. 38—Voltage control of alternating-current generator.

In the case of a direct-current generator, the type of control used is that of Fig. 7(c), and a suitable circuit<sup>46</sup> for performing this function is given in Fig. 39. As the controlling voltage to the grid circuit is direct, it can be made a function of the output voltage or current of some device. A flat voltage-regulation curve up to the full output of the device can thus be obtained. This circuit is used in several applications in this section.

By means of *C* and *R*, the alternating voltage of the thyatron grids is advanced 90 degrees from an antiphase relation to the alternating anode voltage. A bridge with ohmic and non-linear elements is connected across the generator output and develops a direct-current bias. If necessary, the output of the bridge may be amplified by a triode valve before application to the thytrons. For normal output voltage there is no direct-current bias and the thytrons conduct for approximately one half their full time, i.e., for a quarter cycle, thus delivering a certain mean direct current to the generator field. An increase in output voltage unbalances the bridge in one direction and causes a negative bias to be applied to the grids, reducing the conduction period and mean current. A decrease in output voltage results in a positive bias, and hence an increased conduction period and mean current to the generator field. The exciter delivers only alternating current which is rectified, under controlled conditions, by the thytrons, which are operative all the time.

As an example of the control possible, a 36-kilowatt, 200-volt generator is quoted<sup>47</sup> which,

with thyatron control, gave a drop in voltage of only 0.5 percent between zero and full load, whereas when connected as a shunt machine, without control, the regulation was 20 percent. Condenser *C<sub>S</sub>* and resistance *R<sub>S</sub>* form an anti-hunting combination, the values being chosen with regard to the rate of change of generator voltage.

#### 4.3.2 Variable-Speed Motors on Alternating-Current Supply

The use of thytrons has made possible simple and effective means of operating direct-current motors from alternating-current mains. They may be started, stopped, reversed and regulated in speed with negligible power loss and may be controlled by low-powered devices and even directly by photoelectric cells.

Several circuits are possible. The simplest for one direction of rotation only is that of placing a direct-current (shunt- or series-wound) motor as the load in the thyatron circuit. The thyatron is operated as a controlled rectifier; the mean voltage and current to the motor may be readily varied. As only half-wave rectification occurs, the applied alternating voltage should be twice the rated voltage of the motor. Full-wave rectification may be arranged by adding thytrons. Operation is also possible from three-phase alternating-current mains by using a three-phase full-wave rectifier (such as Fig. 52), in which a phase-shifting transformer in the grid circuit of the thytrons will control the speed of the motor.

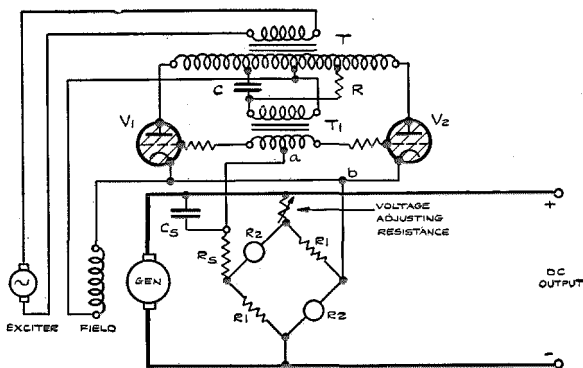

Fig. 39—Voltage control of direct-current generator.

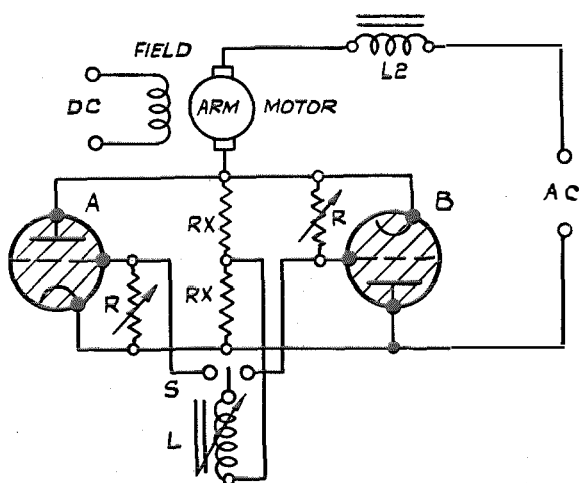

Fig. 40—Variable speed and reversible motor on alternating-current supply.

A simple circuit for single-phase systems,<sup>48</sup> in which reversal and speed control are possible, is given in Fig. 40. Two thyratrons are connected "back-to-back," each operating for one direction of rotation. Phase control of the grids is obtained by the combination of resistance  $R$  and inductance  $L$  as for Fig. 9(a). Variation of either  $R$  or  $L$  allows a wide range of speed control. The direction of rotation is selected by switch  $S$ . If switch  $S$  is arranged to make on both sides simultaneously, the motor will stop immediately as full-wave alternating current will be flowing through the armature. The inertia of the rotor is too great to allow oscillations to be produced by the successively reversed torques. To avoid heating of the armature in the standstill condition, a choke  $L_2$  is inserted in the alternating-current line to limit the current under these conditions. The choke has no air gap and saturates readily when pulsating direct current is flowing, introducing only a small voltage drop when the motor is in rotation. In the circuit shown, positive-grid valves are assumed with the resistances  $R_X$  providing the necessary grid voltages. It is then not necessary to provide a source of negative grid voltage to cut off the valve. Negative-grid valves can be used with obvious modifications.

Instead of having a steady direct-current field for the motor and switching only the armature current by means of the thyratrons, the whole

system may be alternating-current operated by using a series-connected motor which is provided with forward and reverse fields. In this case, one thyatron is associated with each field. Full-wave rectification is readily possible by associating a pair of thyratrons with each field. Such an arrangement is particularly useful where small pilot motors are being controlled, e.g., operating field rheostats for larger motors or generators.

Other methods of control utilising thyratrons, particularly for heavy machines, have been developed<sup>49-51</sup> but are beyond the scope of this paper.

#### 4.3.3 Torque Amplifiers

Torque amplifiers are particularly useful for remote operation of equipment such as tuning elements in large transmitters, earthing or connecting switches, synchronising of rotating machinery such as alternators or in television and facsimile equipment using rotating elements, and where it is desired that any driven apparatus shall follow accurately the movements of the driving mechanism without mechanical means of connection. In all such amplifiers the driving element operates to alter the phase of the thyatron grid voltage so that a corresponding change in anode current takes place. The anode current, usually through the intermediary of a direct-current motor of the types discussed in Section 4.3.2, controls the driven device. In addition, the driven mechanism, when it has followed the driver, renders the thyratrons non-conducting or, in the case of continuously rotating machinery, the thyratrons remain conducting to such an extent that the driven and driving mechanisms rotate in synchronism. The controlling device may be a phase-shifting transformer or a variable element such as a condenser, etc.

The fundamental schematic diagram of one such amplifier operating on a single-phase alternating-current supply is given in Fig. 41. With this arrangement<sup>52</sup> extremely accurate and rapid control is possible. One instance of its use is on a large boring mill in which the positions of the tools are set to an accuracy of 1/1,000th inch by adjusting the dial of the controlling mechanism.

Two groups of thyratrons, *A* and *B*, are connected so that the motor may be rotated in either direction. In addition each group can operate as an inverter if the direct-current motor is oversped a little, as the motor counter-electromotive force will exceed the rectified voltage. No current then flows from the rectifying group, but the inverting group passes current and regenerative braking is obtained. The phase-shifting transformers,  $T_1$  and  $T_2$ , are rigidly coupled together but their connections are arranged so that the electrical rotation of one is opposite to that of the other.

As the controlling handwheel of the synchronous motor *X* is rotated, a torque is given to the receiver synchronous motor *Y* and the grid voltages are altered in phase accordingly. The direct-current motor then operates and in so doing rotates the stator of the receiver *Y*, through gearing, in such a direction as to restore the grid voltage phase-shift to a position corresponding to the rest position, and the main motor thus comes gradually to rest. As shown, full-wave rectification and inversion takes place.

Simpler and less accurate circuits have been used<sup>46</sup> in which the voltage rather than the phase of the alternating bias on the grids of a pair of thyratrons is changed.

A variable capacitance forms the controlling element in the circuit<sup>58</sup> of Fig. 42, which is useful for synchronising rotating machines. The controlling machine *W* has attached to its shaft a sector-shaped plate  $P_1$ , or set of plates, of a variable air-dielectric condenser. The controlled machine *M* has a similar set  $P_2$  coaxial with the first. The direct-current motor *M* is fed by the thyatron *V*, which has an alternating-current anode supply, and the

condenser  $C_1$  and resistance  $R_1$  form the phasing network. The variable condenser  $P_1P_2$  is connected in parallel with  $C_1$  and the capacitance of  $C_1$  is adjusted so that, at the normal speed of *M* and *W*, the sectors on the two shafts are overlapping by about half their area. The two rotating devices will then keep in step, as any tendency for the motor to rotate at a different speed will be checked by the variation in capacitance between the sectors, it being arranged that an increase of speed of *M* alters the capacitance in such a way as to decrease the anode current and reduce the speed of the motor. To enable *M* to be run up to speed, assuming the controlling device *W* is already rotating, switch *S* is opened and the capacitance of  $C_1$  (or the value of  $R_1$ ) is adjusted until the sector plates are about half overlapped. *S* is then closed, and final adjustment made to  $C_1$  to allow for the added capacitance of  $P_1P_2$ . The sectors will then take control.

The circuit was first worked out for synchronising the rotating discs of a television system. *W* was a light phonic wheel connected to the receiver amplifier and driven by the pulses of picture signal or by means of special synchronising

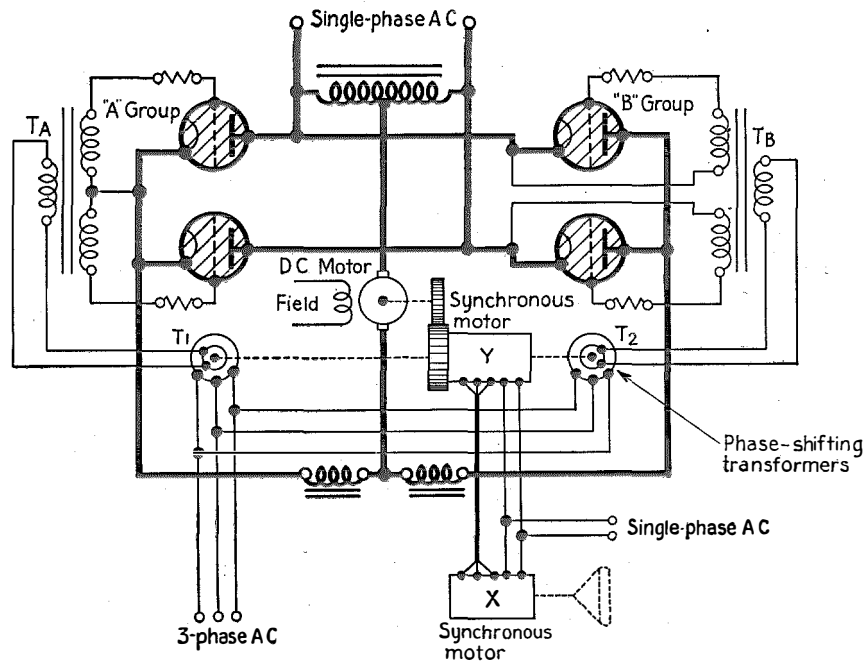

Fig. 41—Torque amplifier.

signals emitted by the transmitter. Other uses suggest themselves where one body is to be kept rotating in synchronism with another and where, if desired, a very considerable amplification in power may be required between the two.

#### 4.3.4 Alternating-Current Regulation

Where the temperature of transmitter-valve filaments is to be raised slowly, two thyratrons may be connected "back-to-back," with appropriate phase control applied to their grids to provide gradual increase of the duration of current flow. This necessitates the thyratrons being capable of carrying the full load current. With valves designed to handle higher voltage and lower current, it is better to adopt the impedance method of control employed in welding.<sup>47</sup> Here (Fig. 43) the transformer  $T_1$ , with step-up ratio, is connected in series with the load, and the secondary is shunted by two thyratrons arranged back-to-back for full-wave conduction. The impedance of  $T_1$  is high and virtually allows no current to pass until the thyratrons are rendered conducting by alteration of the phase of the grid voltage. As the conduction period is increased, the transformer is loaded on the secondary side by a lower and lower impedance until finally it presents only a small leakage reactance and substantially full line voltage is applied to the load.

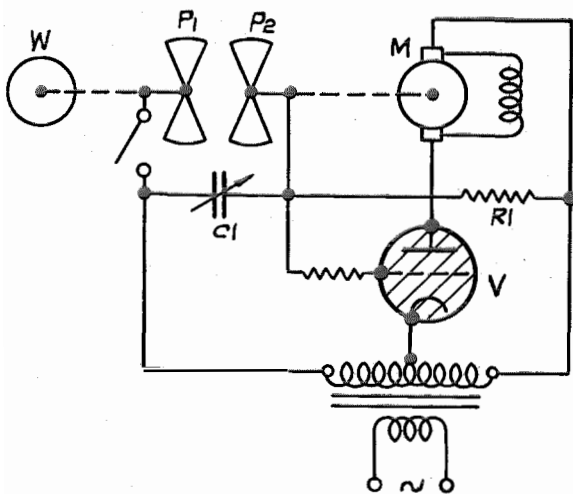

Fig. 42—Synchronising of rotating machinery.

Another method of control, utilised to some extent in America for the dimming of theatre lights, employs a reactor in series with the load. The degree of saturation of its iron core may be controlled, as in Fig. 44, by passing through a separate winding rectified current from thyratrons operating from the alternating-current supply. This circuit also illustrates the control of type 7(d), in which the grid voltage is given a small angle of lead, say 30 degrees, from the antiphase position, and the point of initiation of conduction is controlled by the position of the tap on the voltage divider  $P$ , which varies the amplitude of the grid voltage. This part of the circuit may obviously be used on its own for the control of the direct-current mean output, the load being substituted for the direct-current winding of the reactor  $S$ .

## 4.4 APPLICATIONS AS COMMUTATING DEVICES

### 4.4.1 Motor Commutators and Inverters

This section will be confined principally to a consideration of the use of thyratrons as rectifiers, since their use as motor commutators or inverters has not been made on any large scale in the radio field. However, it is felt that this paper would be incomplete without some mention of these devices and a few selected references are given.

Studies have been made of direct-current motors operating with thyratrons as commutators, and machines have been constructed on this principle.<sup>49, 54</sup>

Inverters provide very efficient means of converting direct into alternating current, and they may be of the parallel<sup>55, 56</sup> or series<sup>57</sup> type. Both types may be driven or self-excited. It is also possible to arrange inverter circuits utilising a single valve.<sup>58, 59</sup> The output can be arranged to be single or polyphase.

The combination of an inverter and rectifier,<sup>55</sup> with the main transformer common to both, provides an efficient direct-current transformer, whilst a rectifier and inverter combination form a static frequency changer, the inverter delivering its alternating output at a frequency determined by the constants of its grid circuit. Likewise, changing from three-phase to single-phase current at the same or a different frequency may be effected.

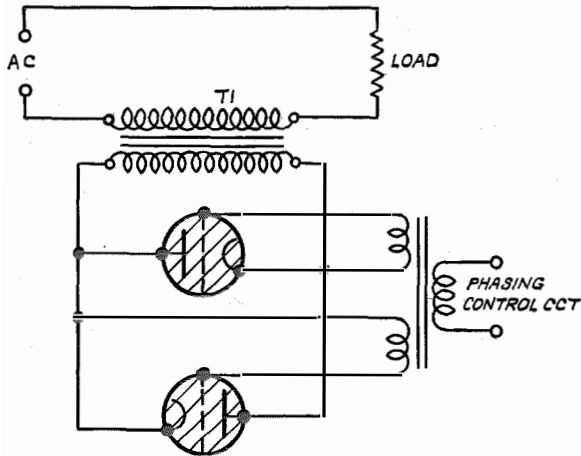

Fig. 43—Impedance control of alternating-current load.

4.4.2 Rectifiers

Probably the widest field of application of thyratrons in radio engineering has been in grid-controlled rectifiers for delivering a direct voltage which can be varied smoothly and easily from a low value to full output. Such rectifiers have found particular application in supplying high anode voltages for transmitting valves. They have the added advantage that protection against overload, occurring either in the load circuit or within the rectifier itself, can be effectively provided. Ignition can be prevented on such an occurrence and the direct current cut off in less than one alternation of the applied voltage. Furthermore, compounding can be arranged so that the output voltage may be held substantially constant for wide changes of output current. The efficiency of these rectifiers is high, particularly in the larger sizes, because of the very low voltage drop across the thyratrons and the high efficiency of the cathode, especially those of the heat-shielded type.

Thyratrons may be used in any of the usual types of rectifier circuits and these will not be discussed in detail. Brief consideration will be given to three-phase rectifiers to describe certain points of their operation and further methods of effecting the grid control.

If the load is purely resistive, current will flow through each valve, in turn, in proportion to the alternating phase voltage and, with the grid control set for maximum output, commutation

will occur when the anode voltage of one phase becomes equal to that of the succeeding phase. The angle of current flow under these conditions is  $2\pi/p$  where  $p$  is the number of "phases" on the side of the transformer connected to the rectifier.

When the firing point is retarded by means of the grid control, the average direct-current output voltage will decrease and at each instant of commutation the current will commence with a steep wave front and will continue to flow, until the succeeding valve ignites or until the phase voltage passes through zero if the ignition point of the succeeding phase is later than this. The point of cut-off occurs when  $\alpha = (\pi/2 + \pi/p)$  and this is also the total angle of delay that must be introduced to reduce the output voltage to zero.  $\alpha$  is the delay angle and is reckoned from the point of intersection of two succeeding phases. The values of  $\alpha$  for different numbers of phases are given in Table II.

TABLE II

TOTAL PHASE SHIFT REQUIRED IN RESISTIVE CIRCUITS TO PRODUCE ZERO OUTPUT VOLTAGE (EXCEPT FOR BRIDGE OR SERIES CIRCUITS)

$p$	2	3	4	6	12	$\infty$
$\alpha$	180°	150°	135°	120°	105°	90°

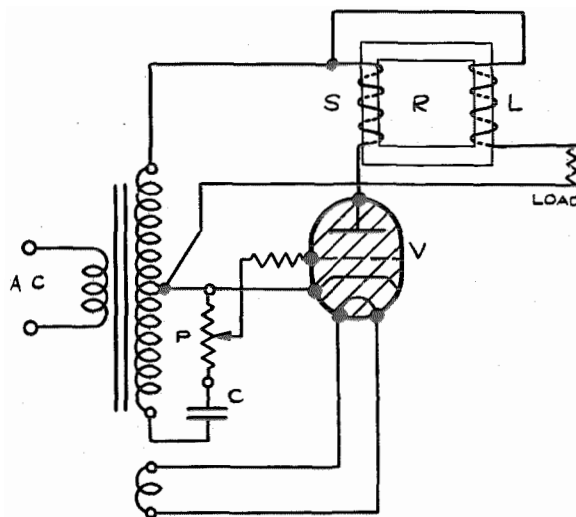

Fig. 44—Reactor control of alternating-current load.



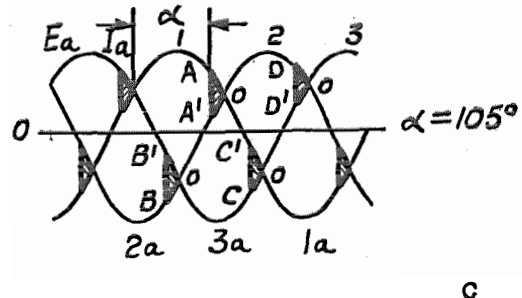
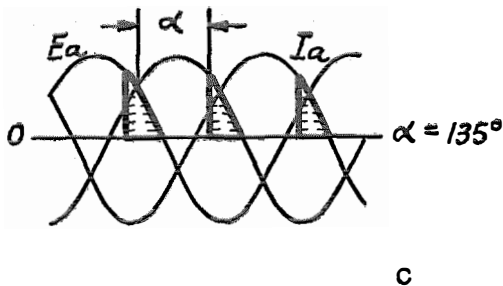
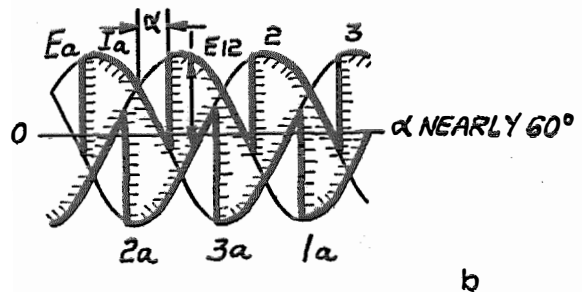
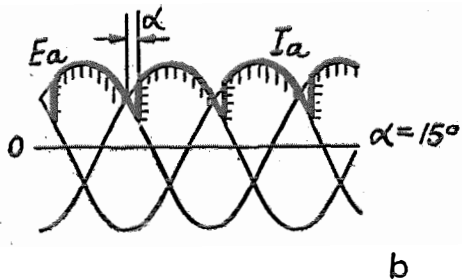
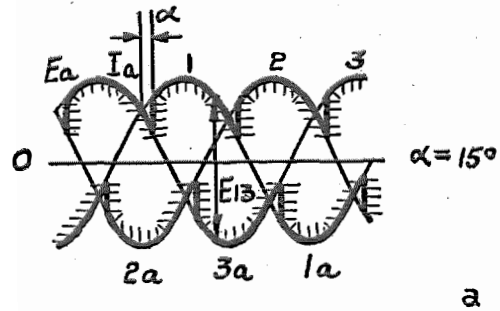
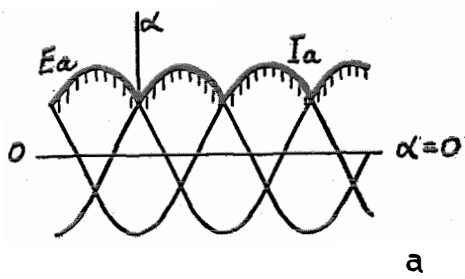

Fig. 45—Voltage conditions in 3-phase half-wave rectifier, with resistive load.

Fig. 46—Voltage conditions in 3-phase full-wave series-circuit rectifier, with resistive load.

The average direct output voltage is expressed by

$$E_{DC} = \frac{p E_{max}}{\pi} \cdot \frac{1 - \sin(\alpha - \pi/p)}{2 \sin \pi/p} - D. \quad (1)$$

(See Fig. 47 for definition of terms.) Fig. 45 illustrates the conditions occurring in a three-phase half-wave circuit with resistive load.

Exceptions to the above generalisations are the single- and three-phase full-wave so-called bridge or series circuits in which, as its latter name implies, two valves are always conducting in series, one on the positive and one on the negative side of the output circuit. The alter-

nating voltage for driving the current is the line voltage in contradistinction to the phase voltage in half-wave circuits. The conditions existing in the three-phase circuit of this type are shown in Fig. 46. For delay angles between 0 and 60 degrees, valve 1 works first with valve 2a and then with 3a, valve 2 with 3a then 1a, and so on, the effective voltage being designated by  $E_{12}$ ,  $E_{13}$ , etc. Even with a purely resistive load, Fig. 46(b), conduction can occur when the phase voltages have reversed because there still exists a driving voltage (e.g.,  $E_{12}$ ) of the correct polarity for the valves to conduct. As the delay angle is increased up to 60 degrees, the output

voltage will decrease. On further increase of  $\alpha$ , this voltage will suddenly drop to zero since the ignition point now occurs after the reversal of the line voltage has taken place, and hence the valves cannot conduct. However, if sine-wave voltages are applied to the grids instead of peak waves, ignition can occur at any point during the half cycle where the grid voltage first exceeds the critical bias, the anode potential being the controlling factor. Thus, in Fig. 46(c), the grid-voltage on valve 1 first allows ignition to occur at point A and valves 1 and 2a can conduct, in series. The grid voltage for valve 2a first allowed ignition to occur at B and because of its sine-wave form it also allows this to occur at A' where valve 1, working in series, applies a potential of the correct polarity to the anode of valve 2a. Thus valve 1 works first with 2a and then with 3a, 2 with 3a followed by 1a, and so on, each valve conducting twice, in short periods (displaced 60 degrees apart), per cycle compared with the single conduction period of Figs. 46(a) and (b). All conduction occurs when the phase voltages are of like polarity but differ in magnitude. Increase of the delay angle up to 120 degrees will, in this case, allow the output voltage to be brought rapidly to zero, i.e., up to the points 0. Beyond this point no further conduction can occur. Up to a delay angle of 60 degrees, conditions are the same as when peak-wave excitation is employed.

For radio work, where a steady value of direct current is nearly always required, a filter circuit is inserted before the load to absorb the variations in output voltage.

With a capacitive input to the filter, the condenser charges to the peak voltage of the

alternating-current wave and discharges through the load during the periods of non-conduction, thus helping to maintain the voltage across the load more constant. However, the current from the rectifier flows into the condenser in short pulses of high peak value. Thyratrons are not well suited for use in such circuits and care must be taken that the peak of this charging current does not exceed the peak current rating of the valve. As a high ratio of peak to mean current results, the direct output current will have to be kept at a relatively low value. Such circuits are rarely, if ever, used as sources of direct current and whenever a condenser is so connected, as in relaxation oscillator circuits, a resistance should be connected between the thyatron and the condenser to limit the current to a safe value. See Fig. 30.

With inductive input to the filter, the inductance tends to maintain the flow of anode current, even after the voltage applied to the rectifier has passed through zero. Instead of the current being broken into pulses separated by periods of no conduction, continuous flow, though variable

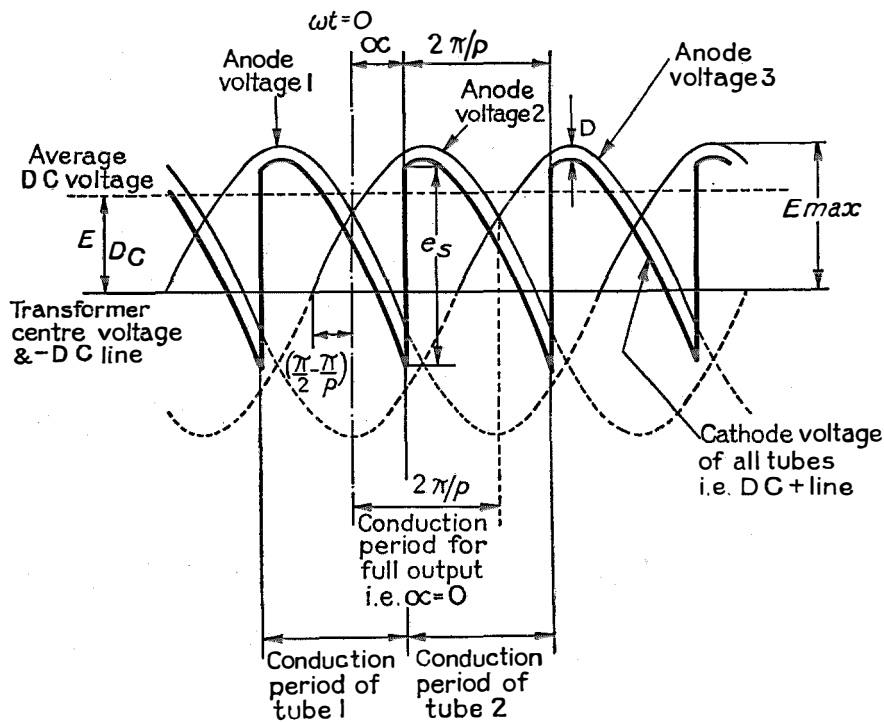

Fig. 47—Voltage conditions in half-wave rectifier having  $p$  phases, with inductive load.

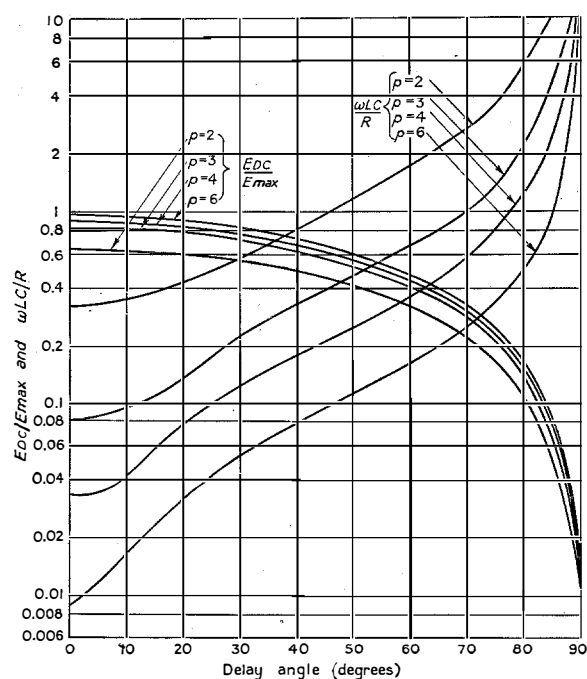

Fig. 48—Critical inductance and direct output voltage as a function of delay angle ( $p$  = number of rectifying phases).

in magnitude, occurs if the inductance is greater than a certain critical value. Under these circumstances, the regulation of the rectifier is greatly improved, the form factor of the current pulses through the valves and transformer is decreased, and the peak current requirement of the valves is lowered. The importance of providing sufficient inductance to allow of this method of operating was first established by Dunham<sup>60</sup> for a single-phase rectifier without grid control, and has since been extended by Overbeck<sup>61</sup> for polyphase circuits employing thyratrons.

When the input choke is greater than the critical value, operation is as indicated in Fig. 47, which shows the voltage relations existing in a polyphase half-wave rectifier of  $p$  phases. Maximum voltage output occurs when one phase takes over from the preceding one when their respective voltages are equal, and the angle of delay  $\alpha$  is reckoned from this point. Since the cathodes are all connected together and form the positive direct-current output terminal, the thick line represents the variation of rectified voltage, this being equal to the anode voltage of which-

ever valve is conducting, less the drop across that valve which is taken as constant for all values of current. Thus, with a firing delay of  $\alpha$ , each valve circuit continues to supply current until the next one fires, even though its anode voltage becomes more negative than the negative output terminal of the rectifier. At the instant of firing, each valve has a greater voltage impressed across it than the amplitude of its sine wave at that instant. As the angle  $\alpha$  is increased the amount the cathodes are driven negative increases until eventually, at the point at which firing should occur, one cathode becomes as much negative below the negative output terminal as the succeeding one is positive, and the net effect is to obtain zero output voltage. It can be seen that this occurs when  $\alpha=90$  degrees in any such circuit. Thus the presence of sufficient inductance to ensure continuous conduction under all conditions also decreases to a value of 90 degrees the angle (compared with that for a resistive load) over which the grid voltage must be shifted to obtain control between full and zero output. The total angle of current flow is always  $2\pi/p$ , which is shifted bodily through the angle  $\alpha$ , and, as mentioned above, the current eventually consists of equal positive and negative components.

The average direct output voltage may be expressed as:

$$E_{DC} = \frac{pE_{max}}{\pi} \sin \frac{\pi}{p} \cos \alpha - D \quad (2)$$

so that the output voltage is proportional to the cosine of the angle by which the grid voltage is delayed with respect to the anode. This expression and the above remarks apply equally to the three-phase full-wave series circuit, except that  $E_{max}$  is to be taken as the line voltage and  $p$  the number of valves in use, i.e., 6. Since the inductance permits conduction to continue even after reversal of the polarity of the driving voltages, peak waves can be employed for the full range of control in the grid circuits.

For rapid and approximate estimation of the critical inductance required when the valve is fully conducting, i.e., with no firing delay angle, one may assume that all the ripple voltage occurs across the inductance and hence for continuous conduction the peak value of the alternating

current resulting from the voltage component of lowest frequency must not exceed the direct current. This leads to

$$p\omega L_C/R > E_{AC}/E_{DC}, \text{ i.e., } \omega L_C/R > 2/p(p^2-1)$$

whence may be obtained the following values of  $L/R$  for different values of  $p$  for a supply at 50 cycles per second. (See Dunham's reply to the discussion on his paper, reference 60.)

$p$	2	3	4	6
$L/R$	1/940	1/3,760	1/9,400	1/33,000

As the question of critical inductance is important, the curves (Fig. 48) relating the several factors have been abstracted from Overbeck's paper (his Fig. 5). In Fig. 48, the values of  $E_{DC}/E_{max}$  and  $\omega L_C/R$  (where  $\omega = 2\pi \times$  line frequency,  $L_C$ =critical inductance in henries, and  $R$ =load resistance in ohms) are plotted against firing delay angle  $\alpha$  for rectifiers having 2, 3, 4 or 6 phases  $p$ . The valve-drop correction  $D$  is left out so that the values of  $\omega L_C/R$  must be multiplied by  $(1+D/E_{DC})$  and the values of  $E_{DC}/E_{max}$  must be divided by the same factor.

The voltage ( $e_s$ ) available to start the discharge at any value of  $\alpha$  is

$$e_s = 2E_{max} \cos(\pi/2 - \pi/p) \sin \alpha. \quad (3)$$

In high-voltage circuits, the valve drop becomes negligible and the delay angle calculated from equation (3) for the minimum striking voltage of the valve under maximum voltage-output conditions may also be neglected as being an extremely small angle. In order that the firing voltage of the valves shall not be too large, a high positive peak voltage is usually applied to the grids at the instant of firing. An example illustrating the delay which may occur in low voltage circuits is given in Overbeck's paper.

The calculated value of inductance is the minimum required to ensure continuous conduction and should always be checked. Two other factors may dictate a higher value being used, viz., ripple attenuation and resonance of the filter circuit at the supply frequency. To avoid the latter on supplies at 50 cycles per second, the product of inductance (henries) and capacitance (microfarads) should not be less than 30.

The diagrams and equations given above treat the rectifier ideally as having no internal reactance. Practically, reactance is always present and produces a delay in commutation (overlap). However, the angle of overlap is less in grid-controlled rectifiers (for values of  $\alpha > 0$ ) than in those without grids because the delay in commutation brought about by the grid-control process results in a higher voltage being actually available when commutation eventually does take place.

When the effects of the reactive and resistive voltage drops in the rectifier transformer are taken into account, the output voltage in half-wave circuits is given by

$$E_{DC} = \frac{pE_{max}}{\pi} \sin \frac{\pi}{p} \cos \alpha - D - \frac{pXI}{2} - \frac{P_R}{I} \quad (4)$$

where  $X$  is the effective commutating reactance per rectifier phase,  $I$  the effective phase current in each secondary winding, and  $P_R$  the transformer resistance loss in each winding.

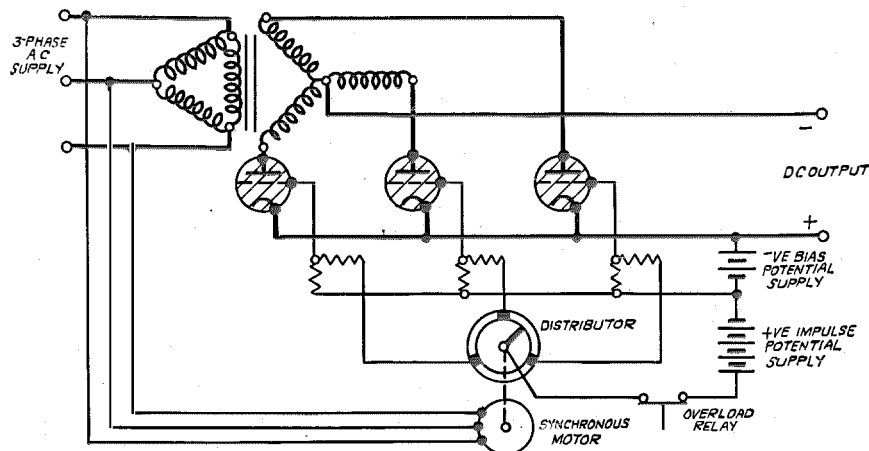

Fig. 49—Three-phase half-wave rectifier with synchronously driven distributor for voltage control.

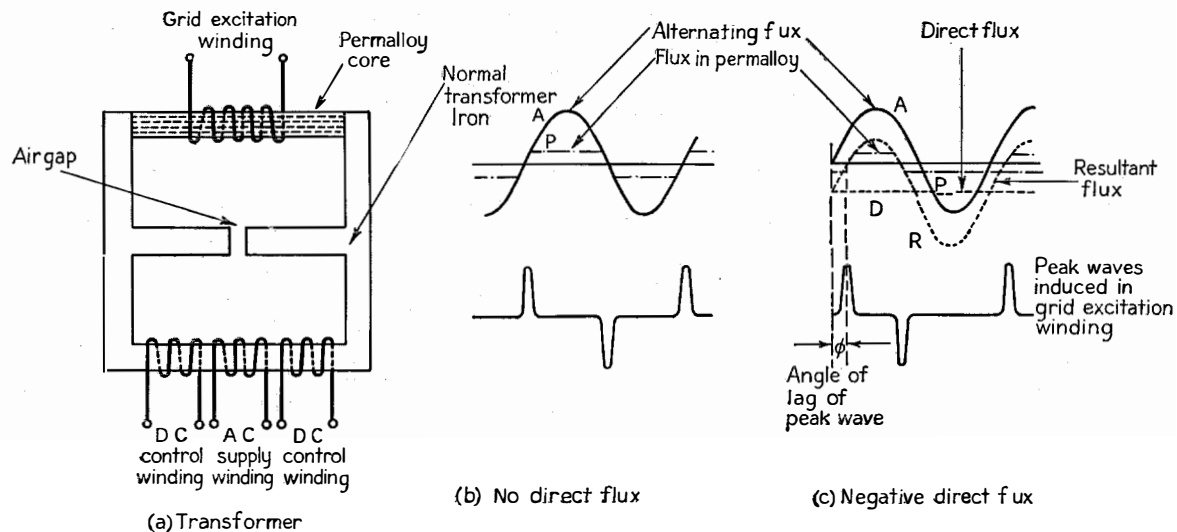

Fig. 50—Peak-wave transformer and wave forms.

In designing the rectifier transformer, consideration must be given to limiting the short-circuit current to a value within the surge-current rating\* of the rectifying valves. It is customary to limit this current by the reactance of the transformer and feeders on the primary side considered as a whole, and, where necessary, to obtain the required value by connecting small anode chokes in series with the transformer secondary terminals. In practice these chokes may be mounted inside the tank and form an integral part of the transformer.

It should be noted that there may be a greater tendency for arbacks to occur with inductive load circuits, for then current conduction ceases when the anode has reached a comparatively high negative value and the space between the electrodes contains a large number of positive ions. This trouble is not often encountered unless valves are being worked near their maximum inverse-voltage rating. It is advisable then to keep the ratio of filter inductance to transformer lumped secondary reactance per phase below a factor of about 5.

It is beyond the scope of this paper to detail full instructions on the design of rectifiers, be-

\* This is the current the cathode is capable of withstanding under infrequent conditions of short circuit. It may be up to 5 times the peak-current rating of the cathode which latter is the maximum value of current the valve can pass under conditions of continuous use.

yond calling attention to the practical points already discussed and other features associated with the grid-control circuits which follow. Reference is, however, directed to several sources in which further information may be found.<sup>62, 63</sup> †

One simple method of grid control is to apply to the grids (through isolating transformers since the cathodes and grids are normally at high potential relative to earth) an alternating potential greater in amplitude than the critical bias corresponding to the peak of the applied anode voltage. The phase of this grid voltage can be changed by a phase-shifting transformer to give the control of Fig. 7(a). Where, however, accurate control of timing and high-speed overload protection are required, the grids may be maintained normally at a negative potential to prevent the establishment of the arc. A positive potential impulse is applied momentarily to each grid in succession, the phase of these impulses relative to the anode potentials being altered to obtain variation of the output voltage, giving the type of control of Fig. 7(b). The impulses may be derived from a source of positive direct voltage in conjunction with a synchronously driven distributor, from peak-wave transformers, or from saturable-core reactors,<sup>19</sup> the two latter cases being completely static devices. Where a

† For summarised information on filters, see reference 64, and for design of rectifier transformers, see reference 65.

distributor is employed, the requisite phase displacement of the impulses is obtained by adjusting the angular position of the rocker supporting the distributor segments. Overload protection is afforded by making the overload relay interrupt the positive direct-current supply to the grid. Such a scheme is illustrated diagrammatically in Fig. 49.

The peak-wave transformer,<sup>66</sup> shown diagrammatically in Fig. 50, has one limb of the core made of permalloy, which saturates at a very low

flux level. As the alternating flux changes sign, sudden reversals of flux occur in this limb inducing a voltage impulse of short duration in the excitation winding. When the permalloy becomes saturated, the main alternating flux passes through the shunt centre limb and the air gap. To obtain a shift of the peak waves, a steady flux is superimposed on the alternating flux by current supplied to one of the direct-current windings. With a steady negative flux as in Fig. 50(c), the resultant flux is such as to give a lag between the position of the peak wave and its position with no steady flux, whilst a positive flux leads to an advance.

These voltage impulses are used to fire the thyatron and since the alternating flux is obtained from the same source that supplies the thyatron anodes, phase control of the instant of firing is readily possible. Variation in both directions is used to obtain the necessary range of angular change. If the steady flux is increased beyond a certain value, saturation of the whole core occurs and peak waves are no longer produced. Before this stage is reached the decrease in the rate of change of flux reduces the amplitude and broadens the shape of the impulses.

The alternating voltage applied to the trans-

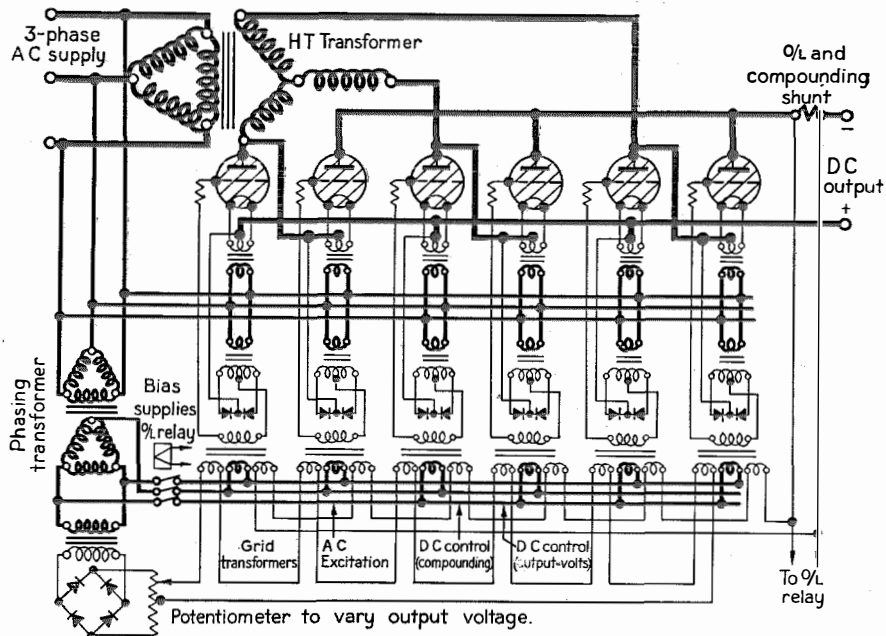

Fig. 51—Arrangement of transformers in 3-phase rectifiers.

former leads the flux by 90 degrees so that with no steady flux the positive peak wave occurs at the maximum of the applied alternating voltage. Now the total shift required of the peak wave, for all circuits with inductance greater than the critical value, is 90 degrees, i.e.,  $\pm 45$  degrees

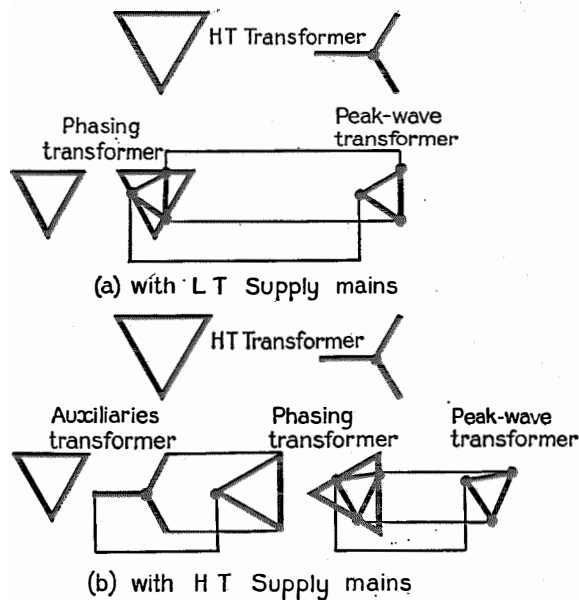

Fig. 52—Three-phase full-wave series rectifier circuit.

from its mid-position. In a three-phase rectifier, as will be evident from Fig. 47, the position when the delay angle  $\alpha=45$  degrees is displaced 15 degrees in advance of the maximum of the applied alternating anode voltage. A permanent phase shift of this amount must be introduced to permit control to full output voltage. One convenient way of obtaining this is shown in Fig. 51, where the relative connections to the various transformers are indicated. The secondary of the high-tension transformer is connected in star as also is that of the transformer feeding the auxiliaries (cathodes and grids), and a phasing transformer is interposed between the latter and the peak-wave transformer. The phasing transformer is connected delta-delta but with the supply to the grid transformers taken off at taps 0.21 of the secondary voltage from the ends of the windings. This gives a 15-degree advance and a voltage  $1/\sqrt{3}$  of the phasing-transformer primary voltage if the latter has a step-down ratio of 1:0.82. Fig. 51(a) shows the arrangement when the supply mains are at low voltage and the auxiliaries can be fed directly from them whilst Fig.

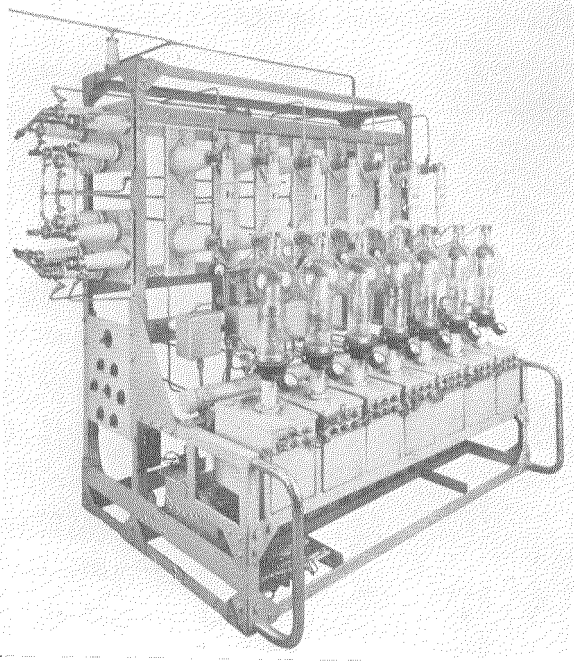

Fig. 53—High-tension rectifier capable of delivering 18,000 volts, 300 kilowatts, direct current, to a transmitter.

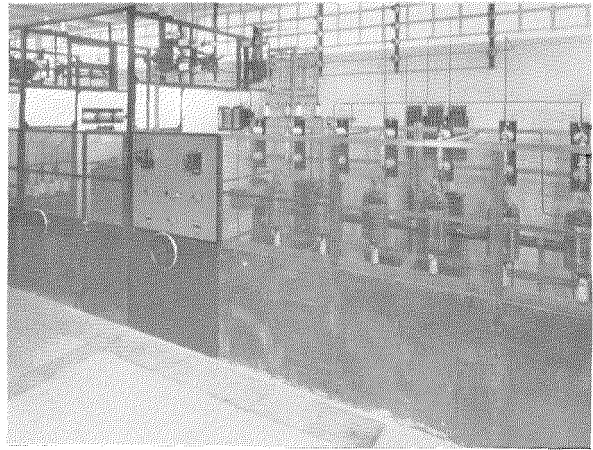

Fig. 54—High-tension rectifier capable of delivering 14,500 volts, 650 kilowatts, direct current to a transmitter.

51(b) is the case for extra-high-tension supply mains requiring a step-down transformer for the auxiliaries. It is often necessary to modify the phase-advance conditions, especially when large delay angles are required, since the peak waves become broadened and ignition occurs before the maximum voltage of the peak wave is reached. Incidentally, Fig. 51(b) also indicates how a 90-degree phase shift, relative to the anode neutral voltage, is obtainable for directly heated cathodes as advocated by manufacturers to ensure more even distribution of the space current drawn from the filament. The single-phase filament transformers are connected in a delta arrangement across the star output of the auxiliary transformer, and the proper phases are selected with respect to the anode voltages of the respective valves.

One very valuable feature of grid-controlled rectifiers is the ease with which extremely rapid overload protection on the direct- and alternating-current sides can be arranged. Quick-acting overload relays interrupt the alternating-current excitation to the grid transformers, thus leaving all grids negatively biased. The overload is usually extinguished in less than one cycle when the voltage of the phase carrying the overload current becomes so highly negative that conduction cannot be maintained. When the overload current ceases, excitation is automatically re-applied and the rectifier again delivers

voltage at whatever value was set by the position of the grid control.

In rectifiers supplying power to transmitting valves, it is usual to provide a counting mechanism such that two overloads may occur within, say, one minute but if a third overload occurs within this period, the circuit breaker or contactor in the high-tension transformer primary circuit is tripped. If the full number of overloads do not occur within the minute, counting starts afresh.

The direct-current overload relays protect the load circuit, whilst those on the alternating-current side are adjustable for time and amplitude, and take care of arcbucks in the valves. For severe alternating-current overloads, such as might occur from a breakdown in the high-tension transformer, additional instantaneous alternating-current overload trips are arranged to work directly in the release circuit of the circuit breaker or main contactor.

Compounding of the rectifier may be arranged by feeding a direct current, proportional to the rectified output current, to a second set of direct-current control windings on the peak-wave transformers. An increase of current, which would normally cause a fall in output voltage, will then advance the grid voltage and keep the output voltage constant.

A simplified schematic of a three-phase full-wave series-type rectifier incorporating the above features is shown in Fig. 52. The several protective and application circuits are omitted for the sake of clarity. In addition to the points already mentioned, interlocking is provided so that the high tension cannot be applied until the cathodes have attained operating temperature. Air is blown around the bases of the valves. Also a delay circuit, composed of inductance and capacitance, is provided in the direct-current control circuit to the grid transformers so that, when first switched on, the rectifier output voltage builds up over a certain period (e.g., 350 milliseconds) to the value determined by the setting of the grid-control voltage divider. The delay is chosen in relation to the filter circuit following the rectifier so that the surge-current rating of the valves is not exceeded. The power required by the peak-wave transformers for full control is very small, a variation of  $\pm 30$  volts at 0.25 ampere being all that is required.

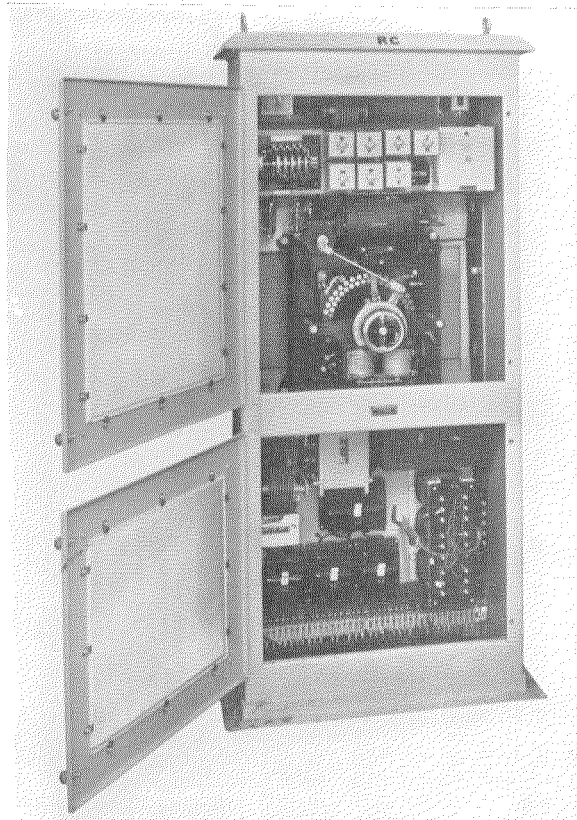

Fig. 55—Grid-control unit for the rectifiers of Figs. 53 and 54.

Obvious simplification can be effected for a half-wave rectifier, since then all cathodes are at the same potential and a common biasing supply and common cathode-heating transformer may be used.

Figs. 53 and 54 are photographs of extra-high-tension rectifiers capable of delivering 18,000 volts, 300 kilowatts, and 14,500 volts, 650 kilowatts, respectively. The thyratrons illustrated in Fig. 2 are utilised. A close-up of the small unit housing all the grid-control apparatus is shown in Fig. 55. The small motor-operated voltage divider serves to effect the grid-voltage phasing as described above; the motor is remotely controlled from a push-button station.

**References**

1. A. J. Maddock, *Jour. Sci. Instr.*, vol. 20, p. 37, 1943.
2. A. W. Hull, *Trans. A.I.E.E.*, vol. 47, p. 753, 1928.
3. A. W. Hull and W. F. Winter, *Phys. Rev.*, vol. 21, p. 211, 1923 (abstract).
4. K. H. Kingdon and I. Langmuir, *Phys. Rev.*, vol. 22, p. 148, 1923.



5. A. W. Hull, *Gen. Elec. Rev.*, vol. 32, pp. 213 and 390, 1929.
6. A. W. Hull, *Gen. Elec. Rev.*, vol. 35, p. 622, 1932.
7. W. Kluge, *Elek. Tech. Zeit.*, vol. 63, p. 201, 1942.
8. W. W. Watrous and D. E. Marshall, "Electronics," p. 42, Jan., 1942.
9. D. D. Knowles and J. W. McNall, *Jour. Appl. Phys.*, vol. 12, p. 149, 1941.
10. A. W. Hull and F. R. Elder, *Jour. Appl. Phys.*, vol. 13, p. 372, 1942.
11. L. B. Snoddy, *Physics*, vol. 4, p. 366, 1933.
12. H. de B. Knight at Electronics Conference of Inst. Phys., *Nature*, vol. 149, p. 278, 1942.
13. G. Rabuteau, *Elec. Commun.*, vol. 15, p. 141, Oct., 1936.
14. O. W. Livingston and H. T. Maser, *Electronics*, p. 114, April, 1934.
15. K. H. Kingdon and E. H. Lawton, *Gen. Elec. Rev.*, vol. 42, p. 474, 1939.
16. A. W. Hull and F. R. Elder, *Jour. Appl. Phys.*, vol. 13, p. 171, 1942.
17. P. Toulon, Brit. Pat. 209,426.
18. L. Dunoyer and P. Toulon, *Comptes Rendus*, p. 179, 1924, and *Jour. de Phys.*, vol. 5, pp. 257 and 289, 1924.
19. M. M. Morack, *Gen. Elec. Rev.*, vol. 37, p. 288, 1934.
20. C. W. La Pierre, *Gen. Elec. Rev.*, vol. 35, p. 403, 1932.
21. G. Smiley, *Electronics*, p. 29, Jan., 1941.
22. E. Hughes, *Jour. Sci. Instr.*, vol. 10, p. 180, 1933.
23. A. Hickling and J. H. Bruce, *Jour. Sci. Instr.*, vol. 15, p. 22, 1938.
24. R. Wideröe, *Elec. Eng.*, vol. 53, p. 1347, 1934.
25. E. J. B. Willey, *Wireless Eng.*, vol. 14, p. 433, 1937.
26. F. V. Hunt, *Rev. Sci. Instr.*, vol. 6, p. 43, 1935.
27. L. B. Turner, *Wireless Eng.*, vol. 14, p. 229, 1937.
28. F. L. Steghart, Brit. Pat. 537,784. Described by D. C. Gall, *Jour. I.E.E.*, vol. 89, Pt. 2, p. 434, 1942.
29. A. J. Maddock and Standard Telephones and Cables, Brit. Pat. 558,224.
30. I. B. Davidson, *Jour. Sci. Instr.*, vol. 11, p. 359, 1934.
31. A. J. Maddock, *Proc. Phys. Soc.*, vol. 43, p. 371, 1931.
32. B. G. Pressey, *Jour. Sci. Instr.*, vol. 15, p. 163, 1938.
33. G. Builder, *Jour. I.E.E.*, vol. 73, p. 419, 1933.
34. H. J. Reich, *Rev. Sci. Instr.*, vol. 3, p. 580, 1932.
35. O. S. Puckle, *Jour. I.E.E.*, vol. 89, Pt. 3, p. 100, 1942, and *Electronic Eng.*, vol. 14, p. 664, 1942.
36. G. Builder and N. F. Roberts, *A.W.A. Tech. Rev.*, vol. 4, p. 165, 1939.
37. V. P. Guljaev, *Jour. Physics (U.S.S.R.)*, vol. 3, p. 21, 1940.
38. W. E. Kock, *Electronics*, p. 20, April, 1939.
39. L. H. Bedford and O. S. Puckle, *Jour. I.E.E.*, vol. 75, p. 63, 1934.
40. H. Pieplow, *Elek. Nach. Tech.*, vol. 15, p. 271, 1938.
41. L. Kersta, *Bell Lab. Rec.*, vol. 22, p. 53, 1943.
42. G. Builder, *Proc. I.R.E.*, vol. 29, p. 177, 1941.
43. K. Kluge, *Phys. Zeit.*, vol. 35, p. 275, 1934.
44. L. A. Meacham, *Bell Lab. Rec.*, vol. 22, p. 179, 1942.
45. P. Sporn and G. Langdon, *Elec. World*, vol. 105, pp. 1182 and 1582, 1935.
46. British Thompson-Houston Co., Engineer, p. 141, 10th Aug., 1934.
47. A. L. Whiteley, *Jour. I.E.E.*, vol. 78, p. 516, 1936.
48. J. D. Ryder, *Electronics*, p. 20, Dec., 1938.
49. E. F. W. Alexanderson and A. H. Mittag, *Elec. Eng.*, vol. 53, p. 1517, 1934.
50. S. D. Fendley, *Gen. Elec. Rev.*, vol. 46, p. 225, 1943.
51. E. E. Moyer, *Electronics*, p. 98, May; p. 119, June; p. 118, July; p. 133, Sept.; p. 128, Oct.; 1943.
52. E. F. W. Alexanderson, M. A. Edwards and C. H. Willis, *Elec. Eng.*, vol. 57, p. 343, 1938.
53. A. J. Maddock and British Thompson-Houston Co., Brit. Pat. 353,056.
54. C. H. Willis, *Gen. Elec. Rev.*, vol. 36, p. 76, 1933.
55. D. C. Prince, *Gen. Elec. Rev.*, vol. 31, p. 347, 1928.
56. R. Feinberg, *Jour. I.E.E.*, vol. 89, Pt. 1, p. 462, 1942.
57. C. A. Sabbah, *Gen. Elec. Rev.*, vol. 34, pp. 288, 580, and 738, 1934.
58. O. W. Livingston and H. W. Lord, *Electronics*, p. 96, April, 1933.
59. H. J. Reich, *Rev. Sci. Instr.*, vol. 4, p. 147, 1933.
60. C. R. Dunham, *Jour. I.E.E.*, vol. 75, p. 278, 1934; Discussion, vol. 76, p. 422, 1935.
61. W. P. Overbeck, *Proc. I.R.E.*, vol. 27, p. 655, 1939.
62. H. Rissik, "The Fundamental Theory of Arc Converters," Chapman and Hall, London, 1939.
63. C. C. Herskind, *Elec. Eng.*, vol. 53, p. 926, 1934.
64. M. Mariani, *Alta Frequenza*, vol. 11, p. 67, 1942. See also *Philips Trans. News.*, Nov., 1940.
65. E. V. DeBlieux, *Gen. Elec. Rev.*, vol. 40, pp. 412, 481, 539, 590, 1937.
66. O. Kiltie, *Elec. Eng.*, vol. 51, p. 802, 1932.

# The Measured Characteristics of Some Electrostatic Electron Lenses—Discussion

IN the original article, published in Electrical Communication, vol. 21, no. 3, 1943, pp. 194-204, there is proposed an empirical formula for the magnification (lateral) of electron lenses. This formula has the form

$$m = kq/p, \quad (1)$$

where  $m$  = lateral magnification,  
 $k$  = a constant of the order of 0.8,  
 $q$  = image distance, distance from image to reference plane in lens, and  
 $p$  = object distance, distance from object to reference plane in lens.

Theoretically, from Lagrange's law the lateral magnification is expected to have the form

$$m = \frac{q}{p} \sqrt{\frac{V_1}{V_2}}, \quad (2)$$

where  $V_1$  = potential on fore part of lens, object side, and  
 $V_2$  = potential on aft side of lens, image side.

If a plot of equation (2) is compared with the measured contours of constant magnification of

the  $p$ - $q$  curves there is a considerable discrepancy.

The apparent discrepancy arises from the fact that in the  $p$ - $q$  curves, as given, the object and image distances are measured from an arbitrary plane in the lens whereas they should be measured from an equivalent thin lens located somewhere between the principal planes of the lens. If, for a first approximation, the thin lens is assumed to be midway between the principal planes, then the proper image and object distances are:

$$q' = q + \frac{1}{2}(|f| - |F| + |f'| - |F'|), \quad (3)$$

$$p' = p - \frac{1}{2}(|f| - |F| + |f'| - |F'|). \quad (4)$$

When the modified Lagrange law of equation (2) is applied with the above values of object and image distance, the dotted contour for  $m=1$  shown on the  $p$ - $q$  curve of the attached figure is obtained. It is seen that the agreement between the theoretical (dotted) and measured (solid)

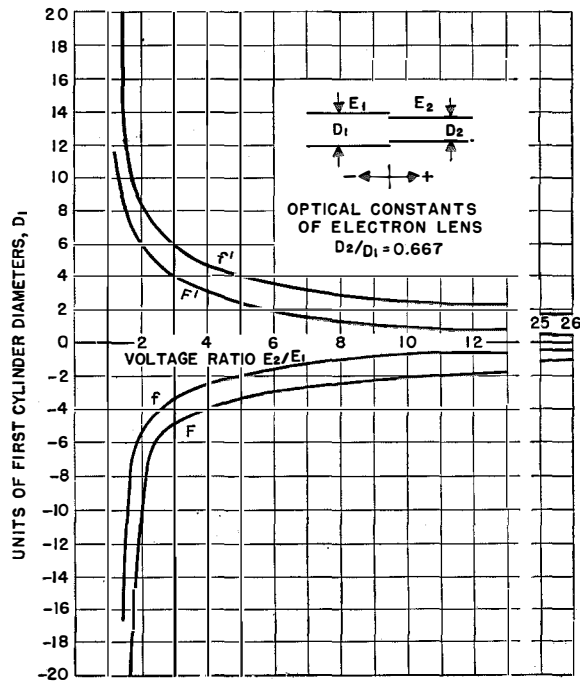
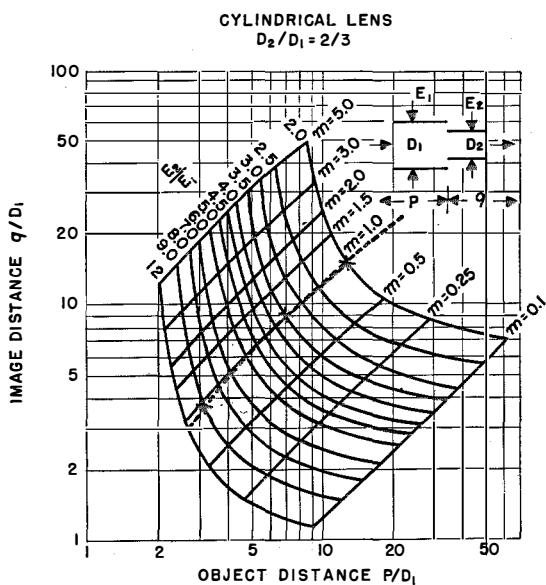

curve is fairly good considering the approximations made. The  $m=1$  contour, if extended to the right and up, eventually becomes asymptotic to the  $p=q$  line. It is interesting to note that, even for values of  $p$  and  $q$  of the order of 15 diameters, the contour is well above the asymptote. It is also to be noted that the contours of constant lateral magnification theoretically have a very low curvature.

The sample calculated contour of constant lateral magnification is representative of the closeness of agreement obtained between measured and calculated values in general.

A transposition in type occurred in the equation just preceding Fig. 13 on page 200 of the original paper and resulted in the erroneous equation,  $m=0.8p/q$ . This should be  $m=0.8q/p$ .

KARL SPANGENBERG

## Recent Telecommunication Developments

**PULSE-TIME-MODULATED MICRO-RAY RELAY SYSTEM DEMONSTRATED.**—Federal Telecommunication Laboratories, Inc., September 27, 1945, gave a demonstration of 24 simultaneous two-way telephone conversations over an 80-mile micro-ray relay circuit including two repeaters and operating at 1,300 megacycles on a single carrier frequency. Pulse-time modulation (PTM) was used. Speech quality was excellent and free from noise.

The fundamentals of PTM have been described in this journal.<sup>1</sup> In the demonstration, a series of 24 speech signals or pulses, plus one synchronizing signal, was transmitted at a repetition rate of 8,000 per second. When the pulses are not modulated, they are transmitted at uniform intervals of time. When modulated, a slight displacement from uniform timing in that particular circuit results. The amount and rate of displacement varies with the modulation. The pulse shape corresponds to a bandwidth of 2.8 megacycles.

Allocation of the channel to each circuit on a time-sharing basis is accomplished by new vacuum tubes which rotate electron beams 8,000 times a second around 25 electrodes. Inasmuch as these tubes, named "cyclodos" and "cyclophon," are used at the transmitter and receiver, respectively, a particular circuit is closed every 8,000th of a second. Intervals of silence are not apparent to the ear.

<sup>1</sup> E. M. Deloraine and E. Labin, "Pulse Time Modulation," *Electrical Communication*, vol. 22, no. 2, p. 91, 1944.

This system of multiplexing is especially well adapted to radio relaying by micro-rays. It involves only on-and-off keying of the high-frequency carrier. No distortions are introduced at successive repeater stations.

In addition to micro-ray relay systems, potential future applications of PTM seem important. Thus, 8 to 12 high-fidelity programs could be broadcast from a single transmitter and antenna system operating on a single carrier frequency. Selection of a particular program at a home receiver would require only a simple switch connected to the cyclophon electrodes. Hence, different broadcast programs in important areas could be furnished from a single transmitter advantageously located; and reception could be improved by favorable disposition of receiving antennas.

As amplitude modulation is not used, PTM systems of this general character can be made practically noise free. They are capable of reproducing signals with great fidelity; and, in addition to telephony and broadcasting, they can be adapted to television, telegraph, and facsimile operation.



**EMERGENCY MARINE RADIO TRANSMITTER**—A new shipboard radio transmitter for emergency service was developed recently by Federal Telephone and Radio Corporation. It provides for five preset frequencies between 350 and 500

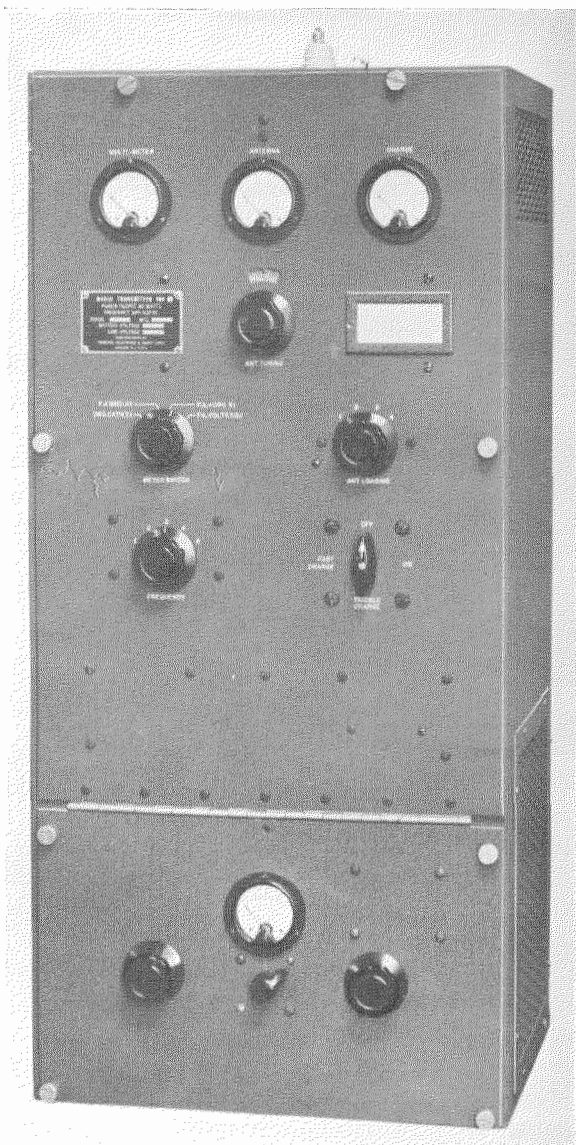

kilocycles per second with a frequency stability better than 0.3 percent. Two master-oscillator and two power-amplifier tubes are operated in full-wave self-rectifying circuits to give an output of 40 watts. Iron-cored inductors are used for the oscillator. The equipment is normally energized from a 12-volt storage battery, the 350-cycle alternating voltage for the plates being obtained from a motor-alternator. A special power unit permits operation from the ship's 115-volt, direct-current system.

• • •

**EXPEDITING INSTRUMENT LANDING OF AIRCRAFT**—The Civil Aeronautics Authority recently demonstrated a new procedure in instrument landing of airplanes whereby it is possible to bring in 20 airplanes an hour in bad weather.

Airplanes awaiting landing were "stacked" at 1,000-foot levels above 2,500 feet at a marker beacon located about 10 miles from the airport. As the lowest airplane, under instructions by radio from the control tower, started its instrument landing approach, the others circled down to the next lower level.

The localizer and glide-path landing transmitters used in the demonstration were constructed by Federal Telephone and Radio Corporation, an associate of I. T. & T. The usual marker beacons at 4.5 miles, 1 mile, and at the field boundary were used in addition to the extra marker over which the planes circled while awaiting landing orders. An average of 3 minutes was required from the time of leaving the "stacked" formation to touching wheels to the runway for each of 23 sequential landings.

• • •

**CONTOUR CASE HARDENING WITH MEGATHERM**—A recent example of the effectiveness of using megacycle-frequency currents for induction heating has been provided by Megatherm equipment manufactured by Federal Telephone and Radio Corporation. On a production basis, a small gear, slightly over 2 inches in diameter and having 51 teeth, has been contour case hardened to a depth of only 0.005 inch. The interior of the gear retained its original hardness of Rc 35 although the case was raised to Rc 58–60. Thus, the toughness of the body was not sacrificed in developing a hard thin skin to resist wear.

As the frequency is increased, the depth of penetration of currents induced in a metallic body becomes less. Also, for a given power, a reduction in penetration results in a greater concentration of current and a higher temperature.

To be free of dimensional deformations and surface scaling, which might cause rejection or require grinding after contour case hardening, the heat should be limited to the surface of the work and be applied for only a short time. The gear

mentioned above was raised to hardening temperature in about  $\frac{1}{4}$  second with a 25-kilowatt Megatherm operated at 5 megacycles per second.



**FRENCH TELEVISION SERVICE**—The French Broadcasting Administration is again placing in service the Eiffel Tower television station for the transmission of 455-line pictures. This transmitter, having a 30-kilowatt peak power output, was designed and installed in 1938 by Les Laboratoires, Le Matériel Téléphonique, an associate company of the International Telephone and Telegraph Corporation. Its operation will aid in developing studio technique.

The French plan to experiment on black-and-white pictures of 750 and 1,000 lines. Low-power transmitting equipment operated at frequencies of 1,500, 600 and 150 megacycles per second will be used.



**I. T. & T. SYSTEM CIRCUITS**—January 1 to August 31, 1945—To supplement the communications facilities of American Armed Forces in Europe, a second mobile radiotelephone and radiotelegraph station was placed in operation by Mackay Radio and Telegraph Company on February 24, 1945, to provide high-speed service directly to New York. It was attached to the U. S. Ninth Air Force while the original station continued with the Third Army.

These two field stations and a fixed Mackay station in Paris transmitted a number of programs which were broadcast in the U.S.A. With the collapse of Germany, the mobile stations moved along with the occupying forces and established communication from Berlin and Frankfurt to New York on July 3, 1945.

On June 10, Mackay closed the Paris station and inaugurated a Paris-New York circuit through facilities of the French P.T.T.

Following VE day, prompt action was taken to reopen Mackay circuits to the following European capitals:

- New York-Copenhagen (May 23, 1945)
- New York-Bucharest (June 25, 1945)
- New York-Prague (July 5, 1945)

As a result of the Italian invasion of Ethiopia, much of that country's communication system was destroyed. A Mackay engineer was sent to rehabilitate these facilities and on May 17, 1945, a direct radio circuit was placed in operation between New York and Addis Ababa, the capital of Ethiopia.

In Japan, under the supervision of the U. S. Army, a direct San Francisco-Tokyo circuit was placed in operation on August 30, 1945, by Mackay Radio and Telegraph Company.

A second radiotelegraph circuit between La Paz, Bolivia, and Buenos Aires, Argentina, was opened in January by Compañía Internacional de Radio Boliviana (Cirbol), the Argentine end being operated by Transradio Internacional. The earlier circuit is being maintained in Buenos Aires by Compañía Internacional de Radio (Argentina). Both the latter and Cirbol are I. T. & T. associate companies.

All America Cables and Radio, Inc., re-established direct radiotelegraph communication between Lima and Rome.

Following the liberation of occupied countries in Europe, direct cable service was re-established by the Commercial Cable Company to its own offices in Paris and Le Havre, France, as well as to its own offices in Antwerp and Brussels, Belgium. Service was also re-established to Holland via Rotterdam.



**LONGQUIMAY-TEMUCO (CHILE) RADIOTELEGRAPH CIRCUIT**—Lonquimay, a village of about 900 inhabitants located about 500 kilometers from Santiago, is normally isolated from the rest of the country for several months each year by heavy winter snows that block its single road and interrupt its one wire-line telegraph circuit. Curiously, this village experiences both the highest and lowest temperatures encountered in the central part of Chile. Valuable data for air transportation are, therefore, collected at a very modern observatory of the Chilean Meteorological Institute.

To insure uninterrupted communication, Compañía Standard Electric Argentina, an International Telephone and Telegraph Corporation associate company, was commissioned to install a radiotelegraph circuit between Lonquimay and Temuco, about 110 kilometers distant.

The transmitters use RK-39 tubes for crystal oscillators and buffers, and RK-47 output tubes. The 100 watts output has proved to be adequate. Capable of operating between 2,500 and 7,500 kilocycles per second, the transmitters are used at frequencies of 5,722 and 5,843 kilocycles. At the Lonquimay terminal, an auxiliary gasoline-electric plant is operated during interruptions of the local electric service. For reception at each station, NC-100 receivers, manufactured by the National Company (U.S.A.), were installed.

• • •

**STRESS CONE FOR HIGH-VOLTAGE CABLE.**—A plastic stress cone, superior in performance to the previously used stress cones made of tapes, has been developed by Intelin Research and Development Laboratories for use in high-voltage cable terminations. The illustration shows the various steps in the manufacture of these cones and their application to a cable.

At the left is a block of dielectric cut from an injection-molded cylinder of polyethylene. The second specimen shows the polyethylene block after machining. The 1/32-inch "feather" edge and smooth curved taper may be clearly seen. The required close tolerances ruled out the molding of this form directly. The third specimen has been masked and is ready for metal electrode spraying. The masking tape extends a short distance down the flare to ensure the maintenance of a properly controlled stress at this point. The cork supports the feather edge and masks the inside of the stress cone. A metal sprayed cone, after the removal of masking, is shown as the last step in its manufacture.

The application of these stress cones to a high-voltage cable is illustrated by the last two models. In the first of these the ground braid extending out from under the Intelin developed plastic jacket is shown tightly bound over the cone electrode. An Intelin developed liquid dielectric displaces the air in the space between the cable dielectric and the inside of the cone. The cable dielectric can be seen extending from the unsprayed end of the cone. A fourteen-inch flash-over path is required for the voltages used in this application. The final step shows the completed stress cone assembly which has had several layers

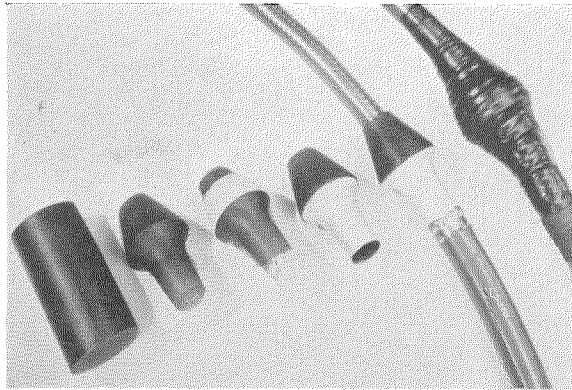

*Steps in production of stress cones and their application to cable.*

of an Intelin developed high-voltage tape applied. The tape is necessary for the retention of the liquid dielectric, for stress grading, and for mechanical protection.

• • •

**POLYSTYRENE FILLING COMPOUND.**—An improved type of hot-melt composition, IN-201, for junction boxes in high-frequency equipments, has been developed by the Research and Development Laboratories, Intelin Products, Federal Telephone and Radio Corporation. Before this development, the use of unfilled joints and connectors using air as the dielectric had been a common practice. This proved unsatisfactory since temperature variations caused moist air to enter the joints and deleteriously affect the performance of the equipment. Existing filling compounds were unsatisfactory in that either electrical properties were poor or their lack of fluidity resulted in the formation of voids at the bottom of small connectors.

An exhaustive study was aimed at developing a compound which would have a low power loss, sufficient fluidity to pour at approximately 150 degrees centigrade, and good adhesion to wires and metal enclosures. In addition, it had to be useful over a temperature range of  $-40$  to  $+70$  degrees centigrade, and be relatively soft so that it could be easily removed from junction boxes and connectors.

After considerable study and experimentation with many varied formulations, a modified poly-

styrene compound was developed having the following properties:

Specific Gravity	1.11
Melting Point (°C.)	115-118
Penetration (ASTM)	57
Dielectric Constant (3 Mc.)	2.21
Power Factor (3 Mc.)	0.006
Volume Resistivity (Ohm Centimeters at 25°C.)	>10 <sup>16</sup>

Because of the highly satisfactory results obtained, this improved potting compound has been supplied in steadily increasing quantities for both company and outside uses.

• • •

**F** T.R. ARMY-NAVY E AWARD—On June 30, 1945 Robert P. Patterson, Under Secretary of War, wrote: "This is to inform you that the Army and Navy are conferring upon you the Army-Navy Production Award for great ac-

complishment in the production of war equipment. This Award symbolizes your country's appreciation of the fine work of every man and women in the Federal Telephone and Radio Corporation."

At a ceremony at Nutley-Clifton, New Jersey, on July 24, the formal presentation of the pennant was made by Major General James A. Code, Jr., Assistant Chief Signal Officer, and accepted in behalf of the workers of Federal by President Sosthenes Behn.

• • •

**T**HIRD STAR TO ARMY-NAVY E AWARD TO FEDERAL LABORATORIES—The ceremony adding the third star to the Army-Navy E Award originally conferred in April, 1943, to the Federal Telephone and Radio Laboratories, now Federal Telecommunication Laboratories, Inc., was held in Nutley, New Jersey, on August 11, 1945.

# INTERNATIONAL TELEPHONE AND TELEGRAPH CORPORATION

## Associate Manufacturing and Sales Companies

### UNITED STATES OF AMERICA

INTERNATIONAL STANDARD ELECTRIC CORPORATION, New York, New York  
 FEDERAL TELEPHONE AND RADIO CORPORATION, Newark, New Jersey

### BRITISH EMPIRE

STANDARD TELEPHONES AND CABLES, LIMITED, London, England  
 Branch Offices: Birmingham, Leeds, Manchester, England; Glasgow, Scotland; Dublin, Ireland; Cairo, Egypt; Calcutta, India; Johannesburg, South Africa.  
 CREECH AND COMPANY, LIMITED, Croydon, England  
 INTERNATIONAL MARINE RADIO COMPANY LIMITED, Liverpool, England  
 KOLSTER-BRANDIS LIMITED, Sidcup, England  
 STANDARD TELEPHONES AND CABLES PTY. LIMITED, Sydney, Australia  
 Branch Offices: Melbourne, Australia; Wellington, New Zealand.  
 NEW ZEALAND ELECTRIC TOTALISATORS LIMITED, Wellington, New Zealand

### SOUTH AMERICA

COMPANIA STANDARD ELECTRIC ARGENTINA, SOCIEDAD ANONIMA, INDUSTRIAL Y COMERCIAL, Buenos Aires, Argentina  
 STANDARD ELECTRICA, S.A., Rio de Janeiro, Brazil  
 COMPANIA SERTIBARD ELECTRIC, S.A.C., Santiago, Chile

### EUROPE AND ASIA

VEREINIGTE TELEFON- UND TELEGRAPHEN-WERKE AKTIENGESELLSCHAFT, Vienna, Austria  
 BELL TELEPHONE MANUFACTURING COMPANY, Antwerp, Belgium  
 CHINA ELECTRIC COMPANY, LIMITED, Shanghai, China  
 SPANBAR ELECTRIC DOOS A SPOLECENOS, Prague, Czechoslovakia  
 STANDARD ELECTRIC AKTIESELSKAB, Copenhagen, Denmark  
 COMPAGNIE GENERALE DE CONSTRUCTIONS TELEPHONIQUES, Paris, France

LE MATRIHEL TELEPHONIQUE, Paris, France  
 LES TELETYPEIMPRESSERS, Paris, France  
 LIGNES TELEGRAPHIQUES ET TELEPHONIQUES, Paris, France  
 FERDINAND SCHUCHMART BERLINER FERNSPRECH- UND TELEGRAPHENWERK AKTIENGESELLSCHAFT, Berlin, Germany  
 LORENZ, C., A.G. AND SUBSIDIARIES, Berlin, Germany  
 MIX & GENEFF AKTIENGESELLSCHAFT AND SUBSIDIARIES, Berlin, Germany  
 SUEDETSKE APPARATFABRIK GENESELLSCHAFT M.B.H., Nuremberg, Germany  
 TELEFONFABRIK BERLINGER A.G. AND SUBSIDIARIES, Berlin, Germany  
 NEDERLANDSCHE STANDARD ELECTRIC MAATSCHAPP N.V., Hague, Holland  
 DIAL TELEFONKUTYCSZESZEMENI RESZVÉNY TÁRSASÁG, Budapest, Hungary  
 STANDARD VILLAMOSSÁGI RESZVÉNY TÁRSASÁG, Budapest, Hungary  
 TELEFONGYÁR R.T., Budapest, Hungary  
 FARRERA APPARECCHIATORI PER COMUNICAZIONI ELETTRICHE, Milan, Italy  
 SOCIETA FINANZIARIA ELETTROTELECOMUNICAZIONI, Milan, Italy  
 SOCIETA ITALIANA RETI TELEFONICHE INTERURBANE, Milan, Italy  
 NIPPON ELECTRIC COMPANY, LIMITED, Tokyo, Japan  
 SUMITOMO ELECTRIC INDUSTRIES, LIMITED, Osaka, Japan  
 STANDARD TELEFON- OG KABELFABRIK A/S, Oslo, Norway  
 STANDARD ELECTRIC COMPANY W. POLSKA Sp. z o.o., Warsaw, Poland  
 STANDARD ELECTRICA, Lisbon, Portugal  
 STANDARD FABRICA DE TELEFONE SI RADIO S.A., Bucharest, Romania  
 COMPANIA RADIO ARABA MARTINA ESPAÑOLA, Madrid, Spain  
 STANDARD ELÉCTRICA, S.A., Madrid, Spain  
 AKTIEBLAGET STANDARD RADIOFABRIK, Stockholm, Sweden  
 STANDARD TELEPHONE ET RADIO S.A., Zurich, Switzerland  
 JUGOSLAVENSKO STANDARD ELECTRIC COMPANY AKCIONARNO DRUŠTVO, Belgrade, Yugoslavia  
 TELEOPTIK A.D., Belgrade, Yugoslavia

## Telephone Operating Systems

UNITED RIVER PLATE TELEPHONE COMPANY, LIMITED, Buenos Aires, Argentina  
 COMPANIA TELEFONICA ARGENTINA, Buenos Aires, Argentina  
 COMPANIA TELEGRAFICO-TELEFONICA COMERCIAL, Buenos Aires, Argentina  
 COMPANHIA TELEFONICA PARANAENSE S.A., Curitiba, Brazil  
 COMPANHIA TELEFONICA RIO GRANDENSE, Porto Alegre, Brazil

COMPANIA DE TELÉFONOS DE CHILE, Santiago, Chile  
 CUBAN TELEPHONE COMPANY, Havana, Cuba  
 MEXICAN TELEPHONE AND TELEGRAPH COMPANY, Mexico City, Mexico  
 COMPANIA PUERTANA DE TELÉFONOS LIMITADA, Lima, Peru  
 PUERTO RICO TELEPHONE COMPANY, SAN JUAN, Puerto Rico  
 SHANGHAI TELEPHONE COMPANY, FEDERAL, INC., U.S.A., Shanghai, China

## Radiotelephone and Radiotelegraph Operating Companies

COMPANIA INTERNACIONAL DE RADIO, Buenos Aires, Argentina  
 COMPANIA INTERNACIONAL DE RADIO BOLIVIANA, La Paz, Bolivia  
 COMPANHIA RADIO INTERNACIONAL DO BRASIL, Rio de Janeiro, Brazil

COMPANIA INTERNACIONAL DE RADIO, S.A., Santiago, Chile  
 RADIO CORPORATION OF CUBA, Havana, Cuba  
 RADIO CORPORATION OF PUERTO RICO, San Juan, Puerto Rico  
 † Radiotelephone and Radio Broadcasting services.

## Cable and Radio Telegraph Operating Companies

(Controlled by American Cable & Radio Corporation)

THE COMMERCIAL CABLE COMPANY, New York, New York<sup>1</sup>  
 MACKAY RADIO AND TELEGRAPH COMPANY, New York, New York<sup>2</sup>  
 ALL AMERICA CABLES AND RADIO, INC., New York, New York<sup>3</sup>

THE CUBAN ALL AMERICA CABLES, INCORPORATED, Havana, Cuba<sup>4</sup>  
 SOCIEDAD ANONIMA RADIO ARGENTINA, Buenos Aires, Argentina<sup>4</sup>

<sup>1</sup> Cable service. <sup>2</sup> International and Marine Radiotelegraph services. <sup>3</sup> Cable and Radiotelegraph services. <sup>4</sup> Radiotelegraph service.

## Laboratories

INTERNATIONAL TELECOMMUNICATION LABORATORIES, INC., New York, New York  
 FEDERAL TELECOMMUNICATION LABORATORIES, INC., New York, New York

STANDARD TELECOMMUNICATION LABORATORIES LTD., London, England  
 LABORATOIRES CENTRAL DE TELECOMMUNICATIONS, Paris, France